

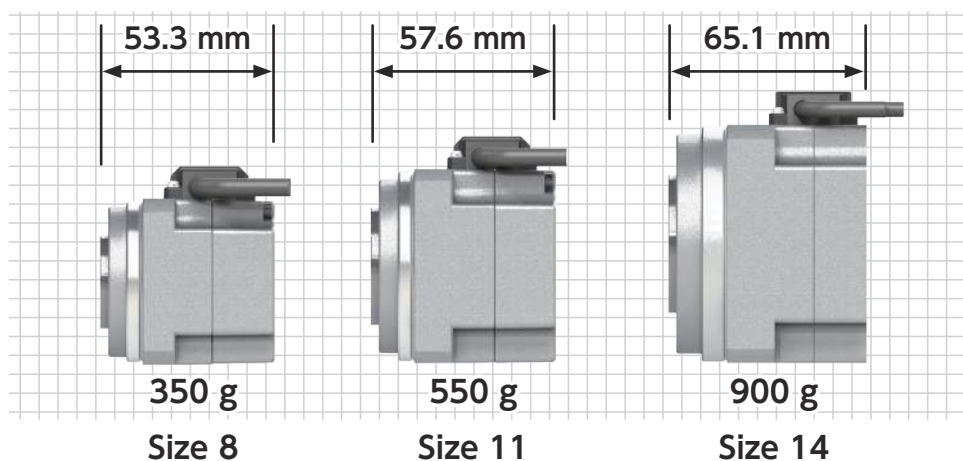

請點擊或掃描QR Code
來找到我們！

MECHATRONICS

Lightweight, Compact, Flat* AC Servo Actuator FHA-C mini Series **LW** Type



Introducing a lightweight, flat type with enhanced form-factor advantages

A new LW type specialized for reduced weight and a thinner profile has been added to the compact, flat AC servo actuator FHA-C mini Series.

Compared with the current type equipped with an absolute encoder, mass has been reduced by 27-31% and total length by 14-17%, while encoder resolution has been improved from the conventional 17 bit to 24 bit for higher performance. (Reduction rates vary depending on size.) Ideal for applications where low weight and a thin profile are required.

* "Lightweight, compact, and flat" refers to a comparison with our products. For details, please refer to page 2.

Maximizing the advantages of compact actuators

The FHA-C mini LW type was designed to maximize the benefits of lightweight and compactness unique to compact actuators. This compact-focused rotary actuator surpasses the current absolute type in both lightness and thinness.



LW type

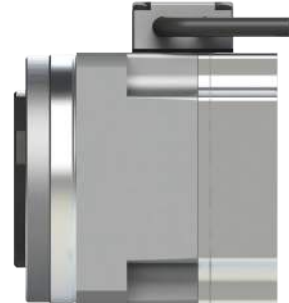

Current absolute type

Mass comparison

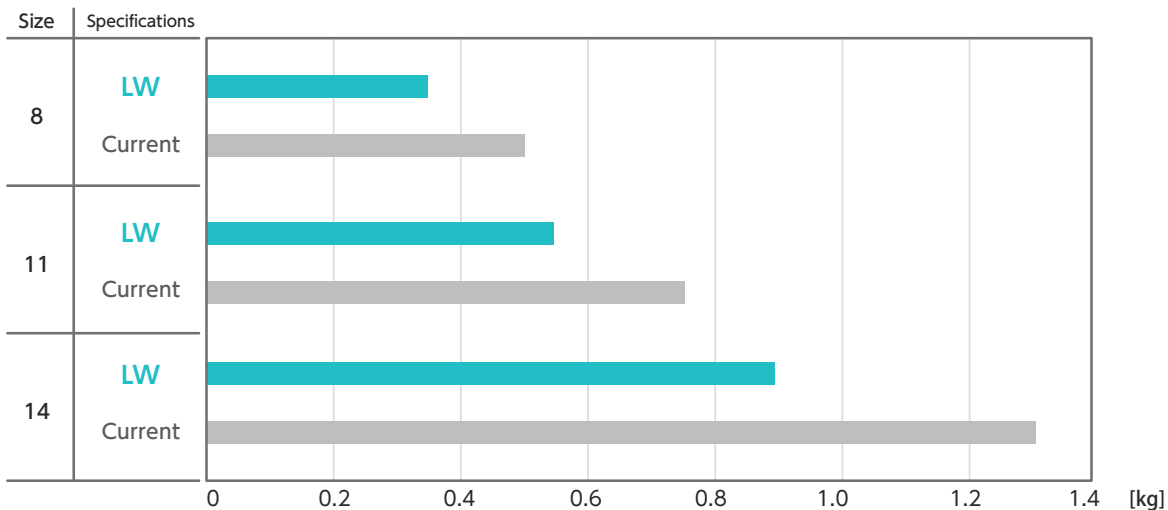

Total length comparison

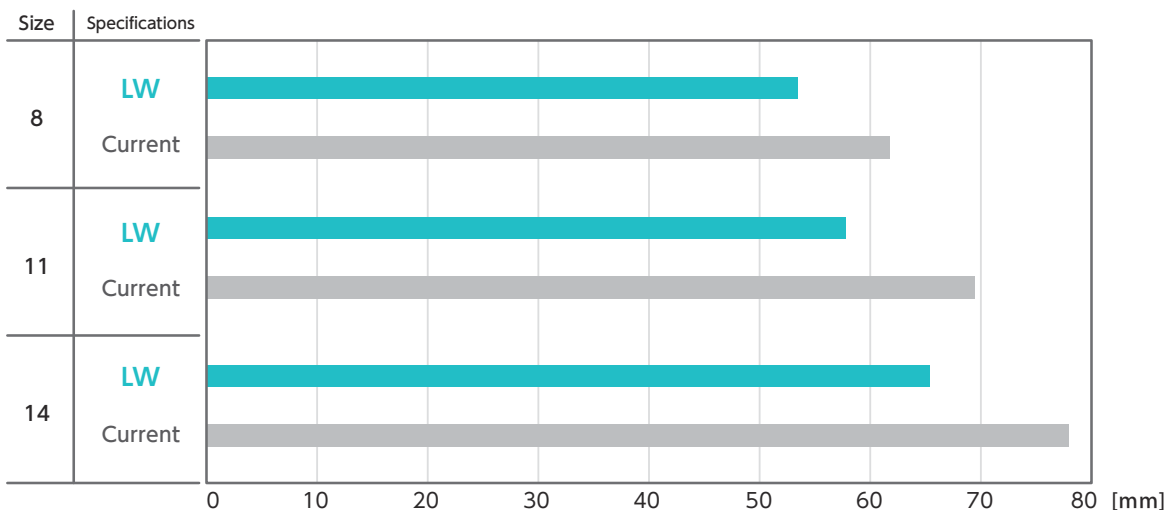

Structure

Compact
Flat

This actuator combines a lightweight, compact HarmonicDrive® with a thin AC servo motor. Compared with the current product, the LW type has a thinner, more compact form. The smallest size weighs only **350 g**.

Output bearing

Thin-type cross roller bearings

Encoder

24-bit absolute encoder

AC servo motor

Compatible
power supply voltage: 100 VAC
200 VAC

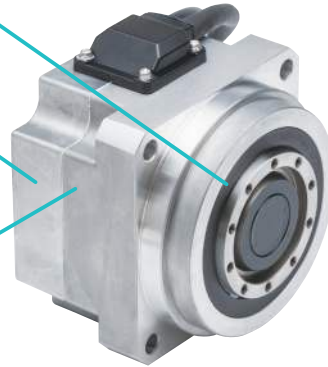

Maximum torque map

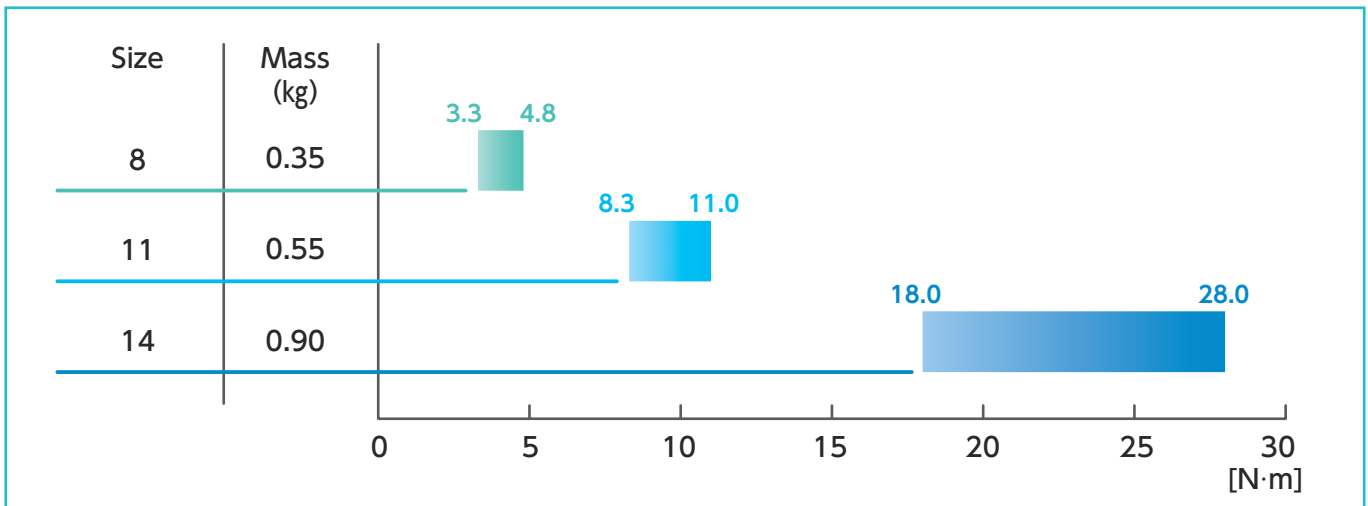

Mechanical accuracy

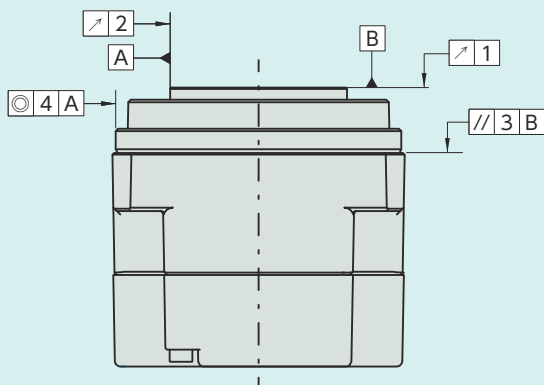

Symbol	Accuracy Item	Size
		8/11/14
1	Output shaft surface runout	0.010
2	Output shaft axial runout	0.010
3	Parallelism between the output shaft and the mounting surface	0.040
4	Concentricity between the output shaft and fitting part	0.055

(T.I.R.*¹ Unit: mm)

*1 T.I.R. (Total Indicator Reading): Indicates the total amount of dial gage reading when the measurement unit is rotated once.

*2 For the measurement method, please refer to the Engineering Data.

Ordering code

FHA - 8 C - 50 - 32 S 24b A - LW - C K - SP

① ② ③ ④ ⑤ ⑥ ⑦ ⑧ ⑨ ⑩ ⑪ ⑫

①	Model name	AC servo actuator FHA-C mini series
②	Size	8, 11, 14
③	Version symbol	C
④	Reduction ratio (expressed by R of 1/R)	50 : 1/50 100 : 1/100
⑤	Encoder format	32 : Conforming to A-format ^{*1} Transmission rate: 4 Mbps, 1-to-1 connection
⑥	Encoder type	S : Multi-turn absolute type (External battery backup method)

⑦	Encoder resolution	24b: 24 bit (16777216 pulses/revolution)
⑧	Input power supply voltage	A : 100 V G : 200 V
⑨	Product specifications	LW : Lightweight specifications
⑩	Connector specification	C : With standard connector
⑪	Cable lead-out direction ^{*2}	None : Lateral (Standard specification) K : Rear Y : Lateral (Opposite)
⑫	Special specifications	No symbol : Standard product SP : Special product

*1 "A-format" is a registered trademark of NIKON CORPORATION.

*2 For the cable lead-out direction, please refer to the Engineering Data.

Specification table

Item		Type	FHA-8C		FHA-11C		FHA-14C	
			50	100	50	100	50	100
Maximum torque ^{*1}	[N·m]		3.3	4.8	8.3	11	18	28
Permissible continuous torque ^{*1,2}	[N·m]		1.5	2.0	2.9	4.2	4.7	6.8
Maximum rotational speed ^{*1}	r/min		132	66	132	66	132	66
Maximum current ^{*1}	A		0.64	0.5	1.6	1.1	3.2	2.4
Permissible continuous current ^{*1,2}	A		0.34	0.27	0.59	0.47	0.87	0.70
Torque constant ^{*1}	N·m/A		6.7	14	6.6	13	7.2	15
EMF constant ^{*3}	V/(r/min)		0.80	1.60	0.80	1.60	0.86	1.70
Phase resistance	Ω (20°C)		14.0		3.7		1.4	
Phase inductance	mH		5.7		3.2		1.8	
Moment of inertia	kg·m ²		0.0059	0.024	0.015	0.059	0.047	0.190
Permissible moment load	GD ² /4 [N·m]		10		23		34	
Moment stiffness	N·m/rad		1.2 × 10 ⁴		2.7 × 10 ⁴		4.0 × 10 ⁴	
Uni-directional positional accuracy	(arc-sec)		120	120	90	90	90	90
Encoder resolution			Absolute encoder: multi revolution 16 bit (65536 pulses/revolution)*4 single revolution 24 bit (16777216 pulses/revolution)					
Output shaft resolution	pulses/revolution		838860800	1677721600	838860800	1677721600	838860800	1677721600
Mass	[kg]		0.35		0.55		0.90	
Input power supply (Driver)	V		AC100V / AC200V					
Combined driver			HA-900A-1A-100/200					
Protective structure			Fully enclosed self-cooled type (IP44)					
Environmental Conditions ^{*5}			Operating temperature: 0-40°C / Storage temperature: -20-60°C Operating humidity / Storage humidity: 20-80% RH (no condensation) Resistance to vibration: 25 m/s ² (frequency: 10-400 Hz) / Resistance to shock: 300 m/s ² *6 No powder or dust, metal powder, corrosive gases, flammable gases, oil mist, etc.; for use indoors; no direct sunlight; less than 1,000 m above sea level					
Mounting direction			Can be installed in any direction.					

The table above shows the typical values for the output shaft.

*1 They are typical characteristics when combined with our driver (driven using an ideal sine wave).

*2 The values are those for temperature rise saturation when mounted on the following aluminum radiation plate: Size 8C/11C: Aluminum radiation plate: 150 × 150 × 6 [mm]
Size 14C: Aluminum radiation plate: 200 × 200 × 6 [mm]

*3 The values are those of the phase-induced voltage constant multiplied by 3.

*4 The multi revolution count range is - 32768 to 32767.

*5 For details, please refer to "3-3 Installation Place and Installation Procedure" in the Engineering Data.

*6 For test conditions, please refer to "1-11 Shock Resistance" and "1-12 Vibration Resistance" in the Engineering Data. Furthermore, this product is not guaranteed for applications involving continuous, prolonged vibration or impact.

Operable range

Input power supply voltage: AC 100 V

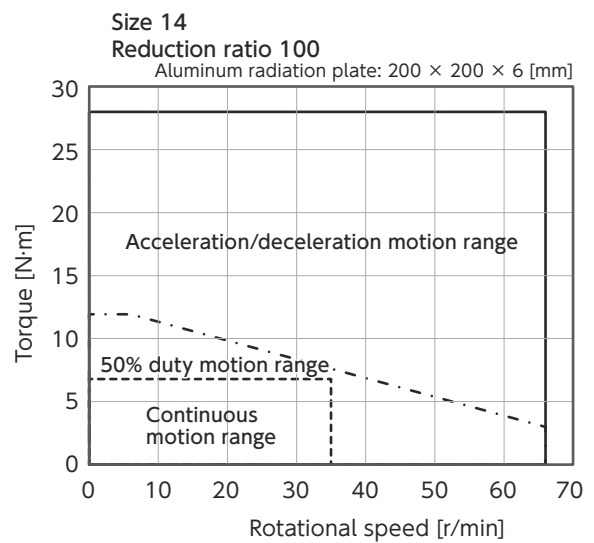
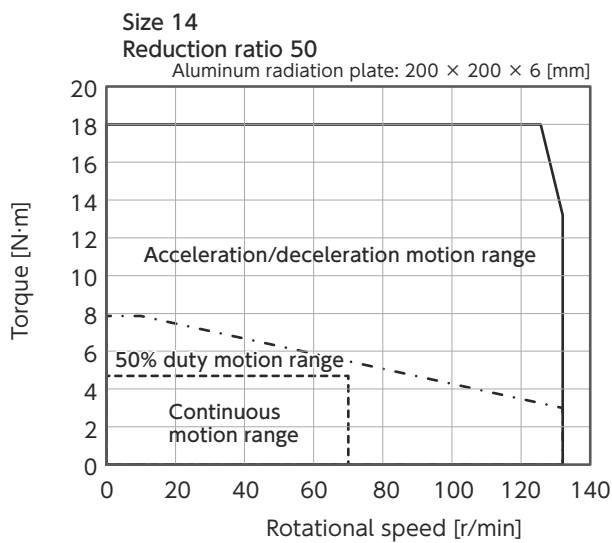
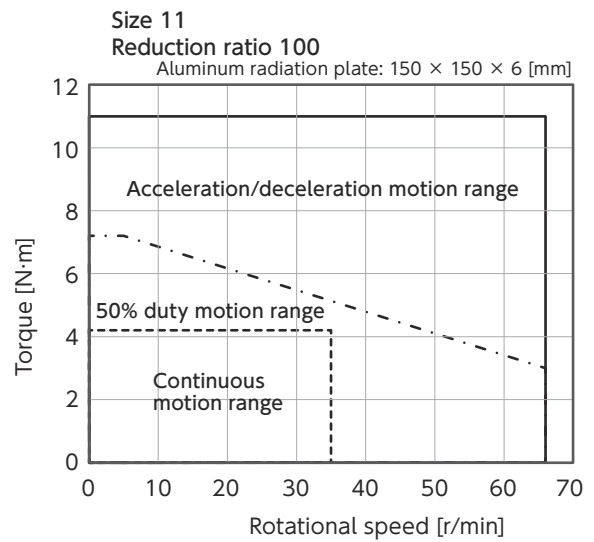
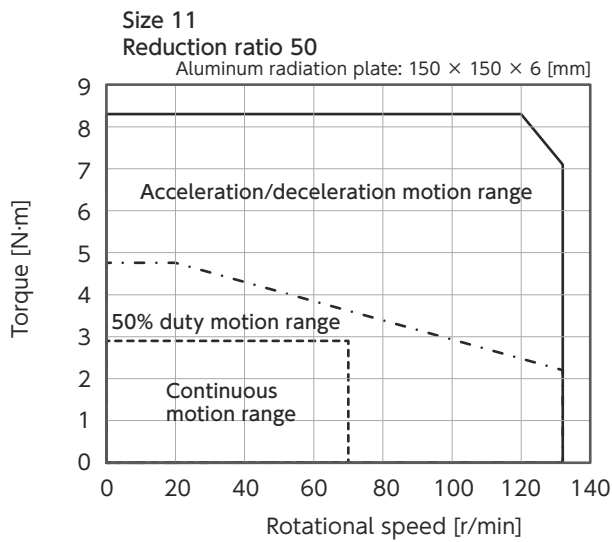
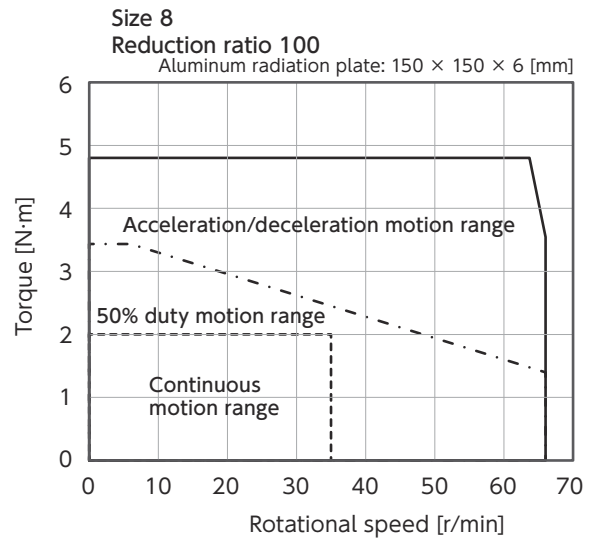
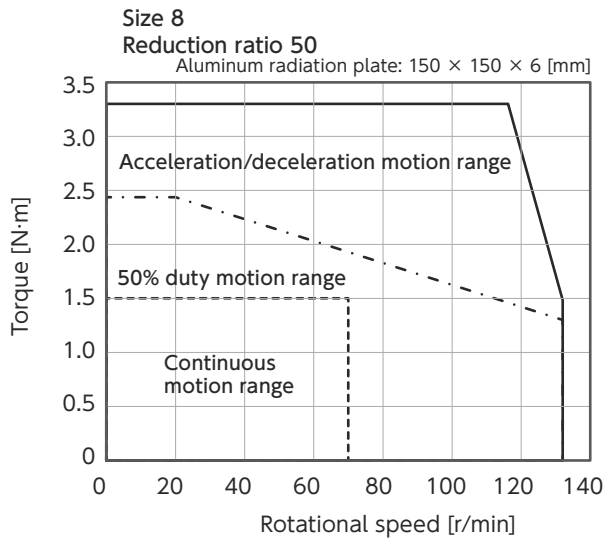

Input power supply voltage: AC 200 V

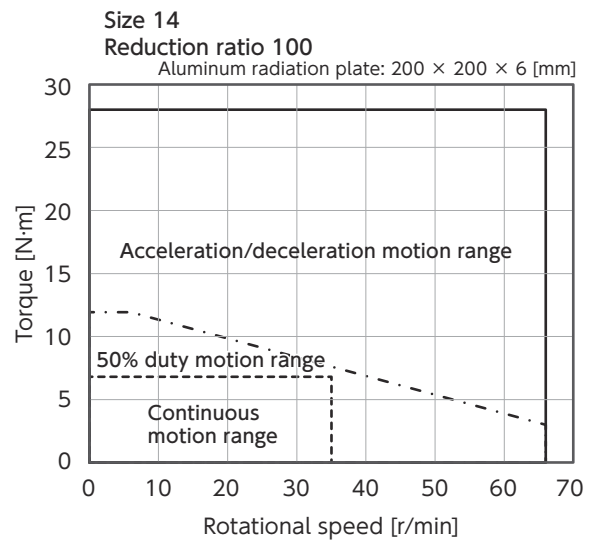
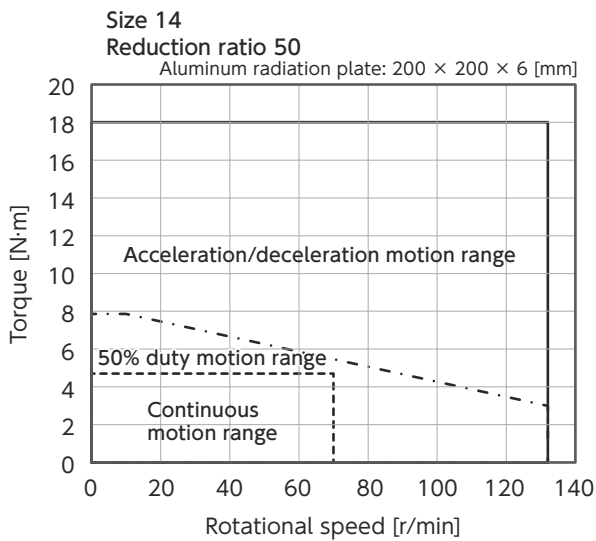
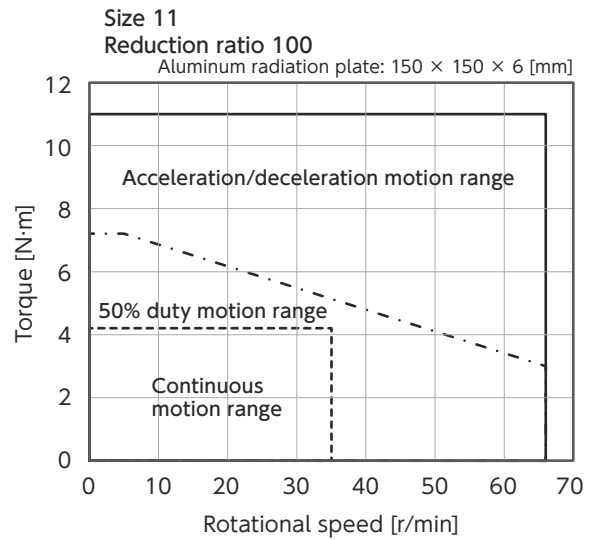
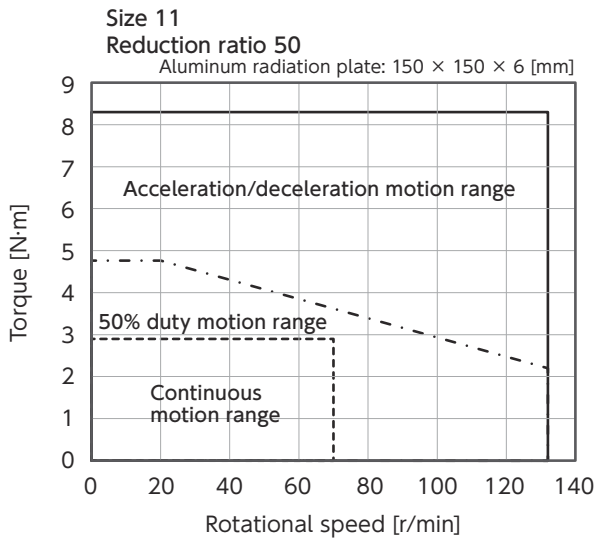
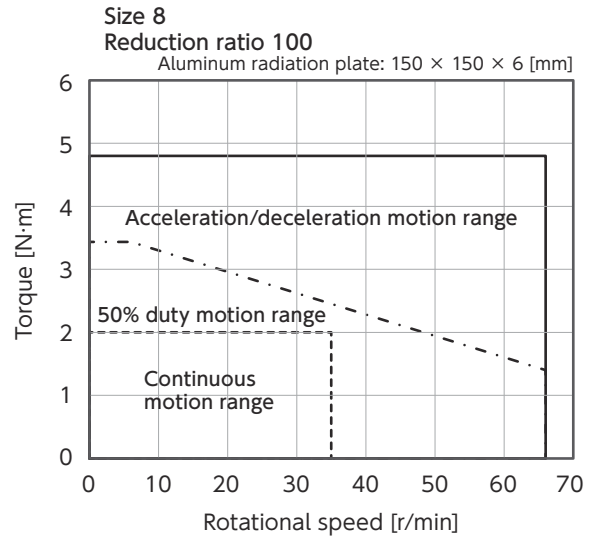
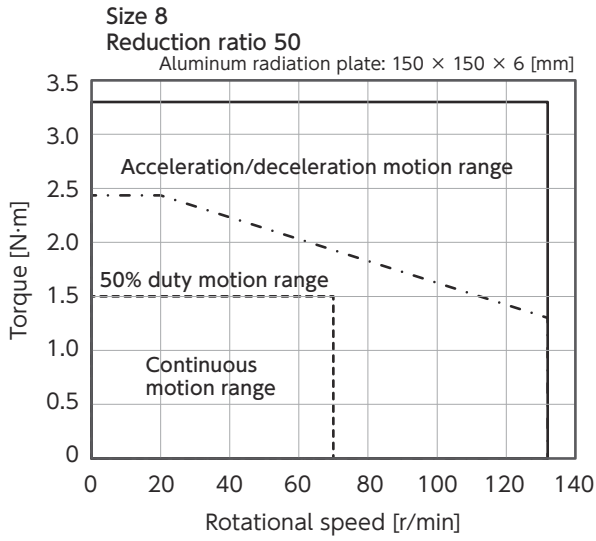

Application examples

■ Scalar-type robot

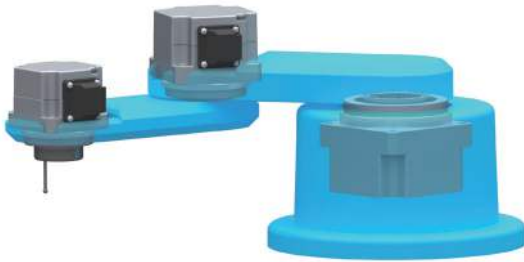

■ Vertical multi-joint type robot

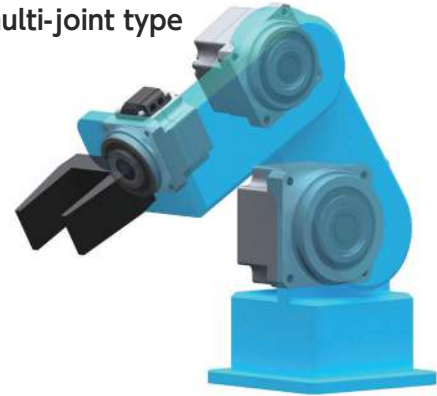

■ Pan/Tilt head

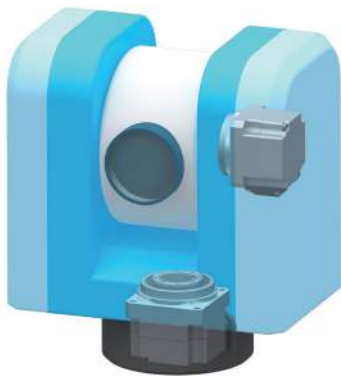

■ Tabletop machine tool



■ Panel carrier device

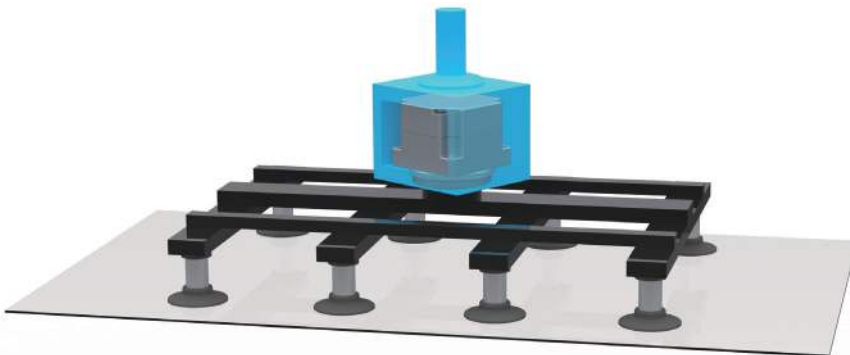

 **Newshiki**
志城實業有限公司

T +886 2 2377 7790

F +886 2 2377 7792

E info@newshiki.com.tw

A 台北市大安區和平東路三段63號4樓之5
統 42636829

Harmonic Drive®
諧波減速機

Ogura Clutch
小倉離合器・制動器

您可以點擊上方對應項目來找到我們！

 **Harmonic Drive Systems Inc.**

■ Please contact our sales department with any questions.

Head Office

Ichigo Omori Building, 6-25-3 Minami-Oi,
Shinagawa-ku, Tokyo 140-0013 JAPAN
Phone: +81-3-5471-7800 / FAX: +81-3-5471-7811

Head Sales office

5103-1 Hotakaariake, Azumino-shi, Nagano
399-8301 JAPAN
Phone: +81-263-81-5940 / FAX: +81-263-50-5010

Tokyo Office

Omori Prime Building 9F, 6-21-12 Minami-Oi,
Shinagawa-ku, Tokyo 140-0013 JAPAN
Phone: +81-3-5471-7830 / FAX: +81-3-5471-7836

Tokyo Office, Kitakanto Team

Omori Prime Building 9F, 6-21-12 Minami-Oi,
Shinagawa-ku, Tokyo 140-0013 JAPAN
Phone: +81-3-6410-8485 / FAX: +81-3-6410-8486

Chubu Office

TM21-2F, 21 Terugaoka, Meito-ku, Nagoya-shi,
Aichi 465-0042 JAPAN
Phone: +81-52-773-7451 / FAX: +81-52-773-7462

Kansai Office

Shin-Osaka Ueno Toyo Building 3F,
7-4-17 Nishi-nakajima, Yodogawa-ku, Osaka-shi,
Osaka 532-0011 JAPAN
Phone: +81-6-6885-5720 / FAX: +81-6-6885-5725

Kyushu Office

NMF Hakata-Ekimae Building 7F, 1-15-20 Hakata ekimae,
Hakata-ku, Fukuokashi, Fukuoka 812-0011 JAPAN
Phone: +81-92-451-7208 / FAX: +81-92-481-2493

Overseas Division

5103-1 Hotakaariake, Azumino-shi,
Nagano 399-8301 JAPAN
Phone: +81-263-81-5950 / FAX: +81-263-50-5010

Hotaka Plant

1856-1 Hotakamaki, Azumino-shi,
Nagano 399-8305 JAPAN
Phone: +81-263-83-6800 / FAX: +81-263-83-6901

"Harmonic Drive" is a trademark of Harmonic Drive Systems Inc.
The academic or generic term of our "Harmonic Drive" products is "strain wave gearing."