

HarmonicDrive® Compact Unit Type CSF-mini Series

Size 7 Added to the Lineup



Size 5



Size 7

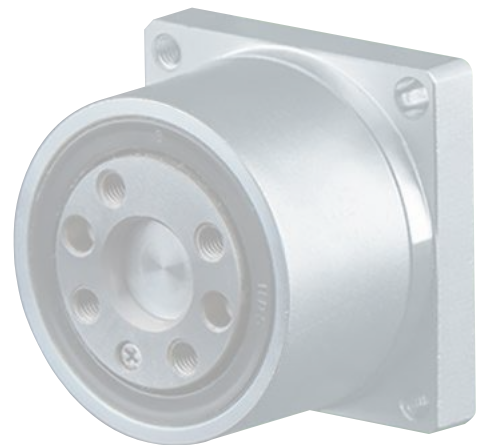

Size 8

The CSF-mini series is a product in which the small sizes of HarmonicDrive® are unitized in a user-friendly manner.

Size 7, with performance and shape that fill the gap between existing Size 5 and Size 8, has been added to allow for optimal product selection.

The “compact four-point contact ball bearing” that has been developed uniquely by HDS is used as the main bearing to enable direct support of the external load.

Feature

Performance and shape that fill the gap between existing Size 5 and Size 8 allow for optimal selection.

Mass comparison

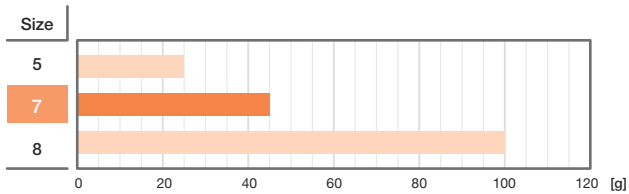

Rated torque comparison at input speed of 2000 r/min

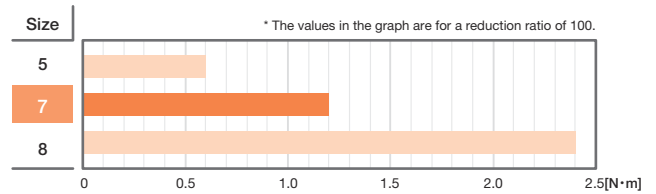

Length comparison

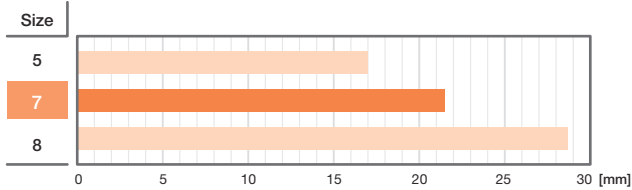

Allowable peak torque comparison at start/stop

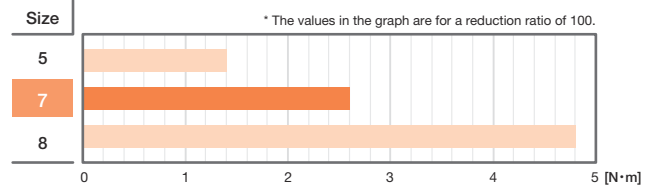

External dimension comparison

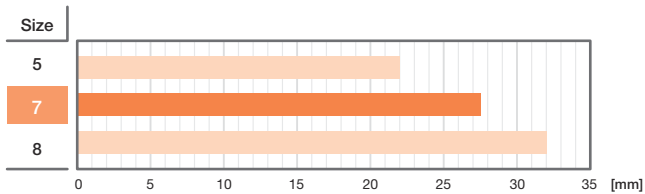

Limit for average torque comparison

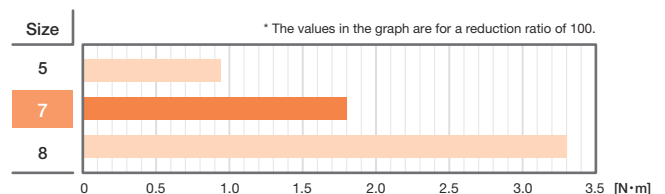

Limit for moment load comparison

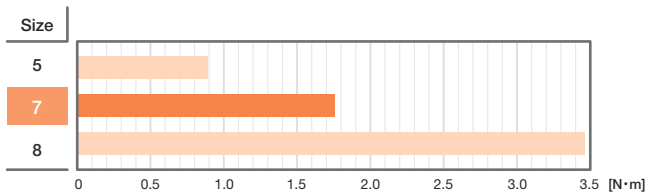

Maximum allowable momentary torque comparison

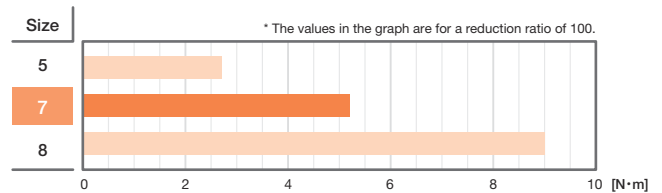

Ordering code

CSF - 7 - 50 - 2XH - F - Specification

Model name	Size	Reduction ratio			Type	Special specifications
CSF-mini series	7	30	50	100	2XH-J = Motor mounted type, shaft output 2XH-F = Motor mounted type, flange output	SP = Special specifications such as the shape or performance Blank = standard product

Rating Table

Size	Reduction ratio	Rated torque at input speed 2000 r/min	Allowable peak torque at start/stop	Limit for average torque	Maximum allowable momentary torque	Allowable maximum input rotation speed	Allowable average input rotation speed	Moment of inertia (1/4GD ²)
		N·m	N·m	N·m	N·m	r/min	r/min	kg·cm ²
7	30	0.48	1.0	0.77	1.8	8500	3500	1.0 × 10 ⁻³
	50	0.8	1.8	1.1	3.5			
	100	1.2	2.6	1.8	5.2			

Outline drawing

Outline drawing: Flange output 2XH-F

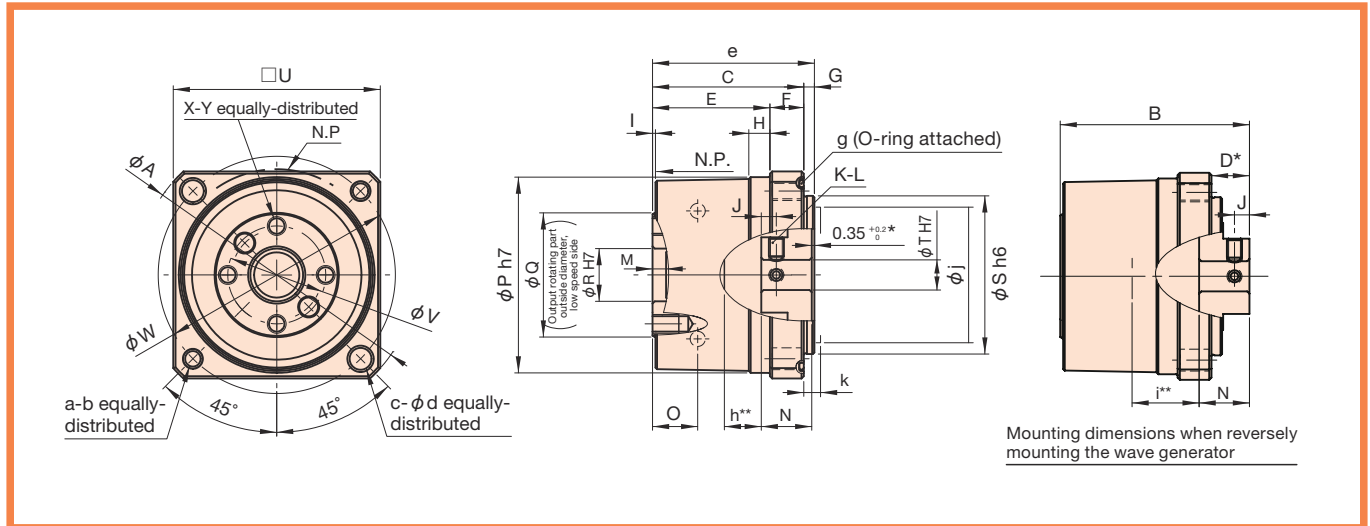

Dimension table

[Unit: mm]

Size	Symbol	ϕA	B	C	D	E	F	G	H	I	J	K	L	M	N	O	$\phi P h7$	ϕQ	$\phi R H7$	
7		37	25.15	20.1	$5.05_{-0.2}^0$	15.6	4.5	1.4	2.8	0.4	2	2	M2x3	1.7	6.7	6	26	16.5	7	
Size	Symbol	$\phi S h6$	$\phi T H7$	U	ϕV	ϕW	X	Y	a	b	c	ϕd	e	f	g	h	i	ϕj	k	Weight (g)
7		21	4	27.5	13	31.5	4	M2.5x3.5	2	M2.5	2	2.9	21.5	-	23.6x0.8	4.9	8.9	18	2	45

Outline drawing: Shaft output 2XH-J

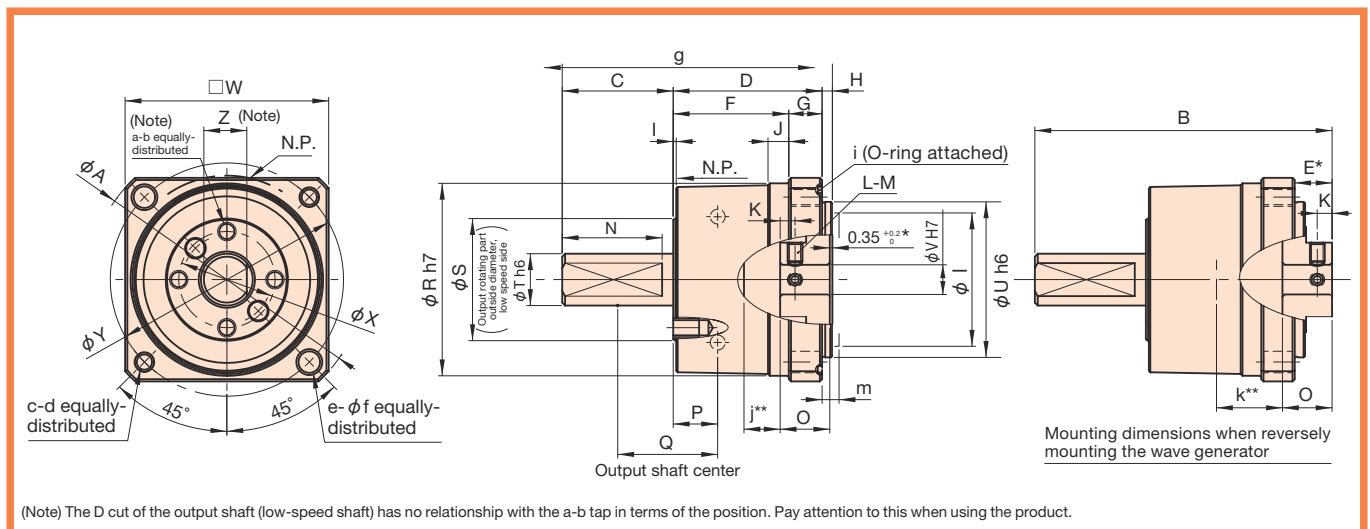

Dimension table

[Unit: mm]

Size	Symbol	ϕA	B	C	D	E	F	G	H	I	J	K	L	M	N	O	P	Q	$\phi R h7$	ϕS	$\phi T h6$
7		37	40.15	15	20.1	$5.05_{-0.2}^0$	15.6	4.5	1.4	0.4	2.8	2	2	M2x3	13.5	6.7	6	13.5	26	16.5	7
Size	Symbol	$\phi U h6$	$\phi V H7$	W	ϕX	ϕY	Z	a	b	c	d	e	ϕf	g	h	i	j	k	ϕl	m	Weight (g)
7		21	4	27.5	13	31.5	6.2	4	M2.5x3.5	2	M2.5	2	2.9	36.5	-	23.6x0.8	4.9	8.9	18	2	50

Wave generator hole diameter dimension

Symbol	Dimension (Unit: mm)
2XH-F: $\phi T H7$	2 to 7
2XH-J: $\phi V H7$	

- Notes: 1. For Size 7, the standard product is the rigid type.
 2. The set screw dimensions may change depending on the hole diameter.
 3. Keyway can be machined depending on the hole diameter.
 4. If the hole diameter dimensions are changed, all products are special-specification products.

- The dimensions marked with * mean the mounting position in the shaft direction and tolerance range of the three parts (wave generator, flex spline, and circular spline) that form HarmonicDrive®. These dimensions affect the performance and strength. Be sure to maintain these dimensions.
- The dimensions marked with ** mean the allowable range of protrusion of the shaft from the wave generator.
- The flexspline deforms elastically. To prevent it from coming into contact with the case, the inner wall dimensions should be $\phi j \cdot k / \phi l \cdot m$ or more.
- When the product is delivered, a wave generator is not incorporated.

Rotational transmission error

Reduction ratio		Size	7
30	$\times 10^{-3}$ rad		0.87
	arc-min		3.0
50	$\times 10^{-3}$ rad		0.73
	arc-min		2.5
100	$\times 10^{-3}$ rad		0.73
	arc-min		2.5

Hysteresis loss

Reduction ratio		Size	7
30	$\times 10^{-4}$ rad		8.7
	arc-min		3.0
50	$\times 10^{-4}$ rad		5.8
	arc-min		2.0
100	$\times 10^{-4}$ rad		5.8
	arc-min		2.0

Stiffness (spring constant)

Symbol		Size	7		
			2XH-J	2XH-F	
T1	N-m		0.15	0.15	
	kgf-m		0.015	0.015	
T2	N-m		0.40	0.40	
	kgf-m		0.041	0.041	
Reduction ratio 30	K1	$\times 10^4$ N-m/rad	0.017	0.017	
		kgf-m/arc-min	0.005	0.005	
	K2	$\times 10^4$ N-m/rad	0.020	0.024	
		kgf-m/arc-min	0.006	0.007	
	K3	$\times 10^4$ N-m/rad	0.027	0.030	
		kgf-m/arc-min	0.008	0.009	
	$\theta 1$	$\times 10^{-4}$ rad	8.9	8.9	
		arc-min	3.1	3.1	
	$\theta 2$	$\times 10^{-4}$ rad	21	19	
		arc-min	7.3	6.7	
	Reduction ratio 50	K1	$\times 10^4$ N-m/rad	0.020	0.027
			kgf-m/arc-min	0.006	0.008
K2		$\times 10^4$ N-m/rad	0.030	0.037	
		kgf-m/arc-min	0.009	0.011	
K3		$\times 10^4$ N-m/rad	0.034	0.047	
		kgf-m/arc-min	0.010	0.014	
$\theta 1$		$\times 10^{-4}$ rad	7.4	5.6	
		arc-min	2.5	1.9	
$\theta 2$		$\times 10^{-4}$ rad	16	12	
		arc-min	5.4	4.2	
Reduction ratio 100		K1	$\times 10^4$ N-m/rad	0.030	0.044
			kgf-m/arc-min	0.009	0.013
	K2	$\times 10^4$ N-m/rad	0.037	0.054	
		kgf-m/arc-min	0.011	0.016	
	K3	$\times 10^4$ N-m/rad	0.044	0.064	
		kgf-m/arc-min	0.013	0.019	
	$\theta 1$	$\times 10^{-4}$ rad	4.9	3.4	
		arc-min	1.7	1.2	
	$\theta 2$	$\times 10^{-4}$ rad	12	8.1	
		arc-min	4.0	2.8	

* Torsional stiffness shows the reference values. The lower limit value is approximately 80% of the displayed value.

Starting torque

[Unit: cN·m]

Reduction ratio	Size	7
30		0.87
50		0.59
100		0.44

Speed-up starting torque

[Unit: N·m]

Reduction ratio	Size	7
30		0.49
50		0.36
100		0.47

Ratcheting torque

[Unit: N·m]

Reduction ratio	Size	7
30		5.7
50		6.6
100		7.5

Buckling torque

[Unit: N·m]

Reduction ratio	Size	7
All reduction ratios		19

Efficiency characteristics

The efficiency varies depending on the following conditions.

- Reduction ratio
- Input rotation speed
- Load torque
- Temperature
- Lubrication condition (Lubrication type and amount)

Measuring condition

Lubrication condition	Speed reducer	Main bearing
	Harmonic Grease® SK-2	Multemp HL-D*

The torque value is measured after two or more hours run-in at 2000 r/min input rotation speed.

* "Multemp" is a registered trademark of KYODO YUSHI CO., LTD.

Efficiency compensation coefficient

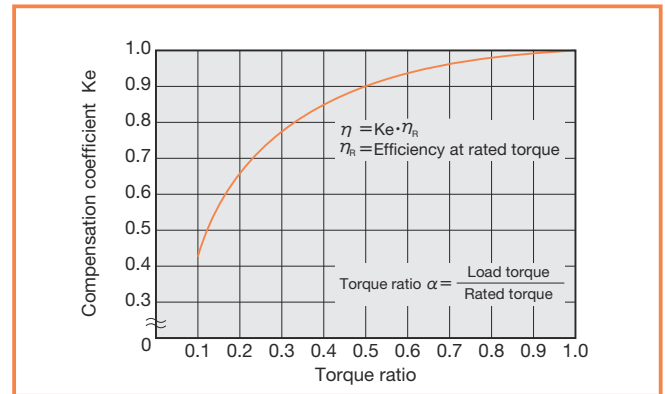

Efficiency at rated torque: Size 7

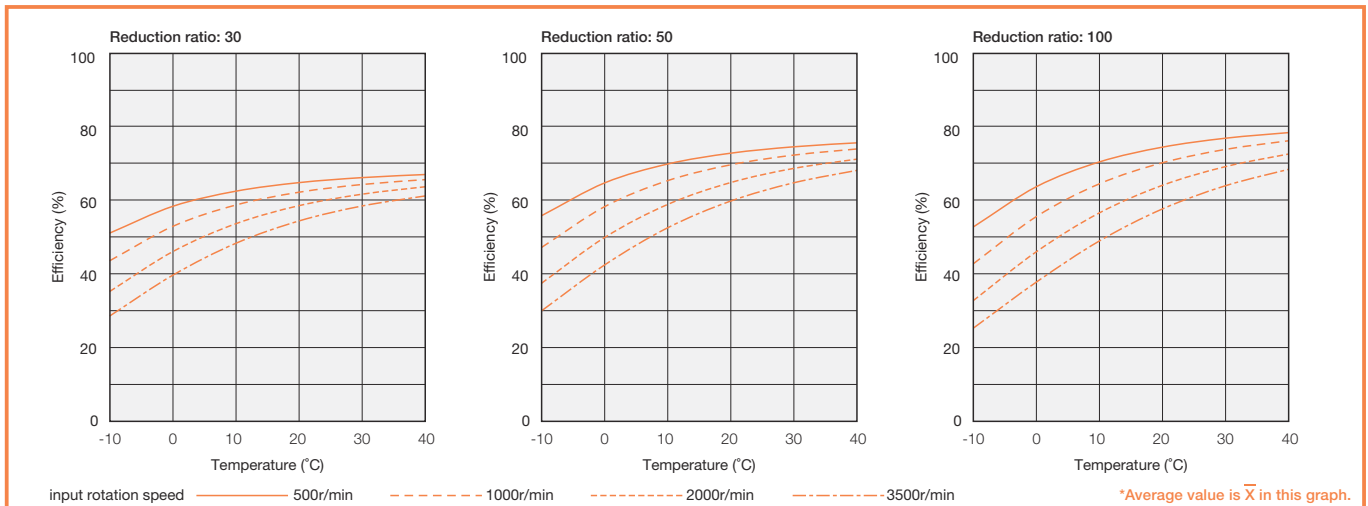

No-load running torque

Measuring condition

Lubrication condition	Speed reducer	Main bearing
	Harmonic Grease® SK-2	Multemp HL-D*

The torque value is measured after two or more hours run-in at 2000 r/min input rotation speed.

* "Multemp" is a registered trademark of KYODO YUSHI CO., LTD.

No-load running torque correction quantity

[Unit: cN·m]

Reduction ratio	Size	7
30		0.30
50		0.13

No load running torque at reduction ratio 100

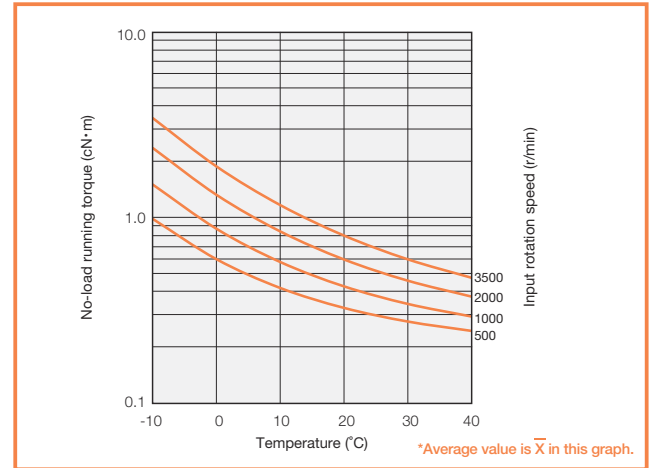

Specifications of the main bearing

The CSF-mini series is equipped with the precision 4-point contact ball bearing to directly support the external load (output part).

To achieve the full performance of the CSF-mini series, check the maximum moment load, life of the 4-point contact ball bearing and static safety coefficient.

Procedure for checking

For details of the procedure for checking, refer to "Checking main roller bearing" in "Engineering Data" in the HarmonicDrive® General Catalog.

(1) Checking the maximum moment load (M max)

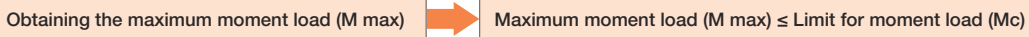

(2) Checking the life

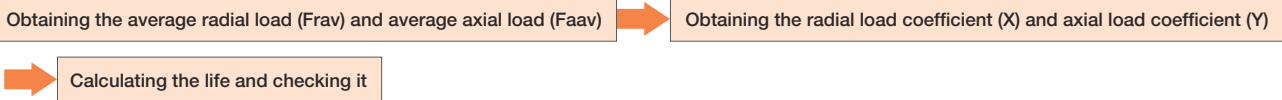

(3) Checking the static safety coefficient

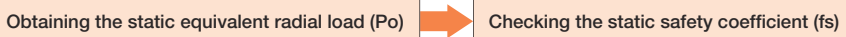

Main bearing specifications

Size	Pitch circle of ball	Offset	Basic rated load		Limit for moment load	Moment stiffness	Allowable radial load	Allowable axial load
	dp	R	Basic dynamic load rating C	Basic static load rating C0				
	mm	mm	×10 ² N	×10 ² N				
7	17	6	14.4	12.1	1.76	1510	140	440

* Basic dynamic load rating is the certain static radial load at which the basic dynamic load life of the bearing is 1 million rotations.

* Basic static load rating is the static load that produces a certain level of contact stress (4.2kN/mm²) at the center of the contact area between the rolling contact area under the maximum load and raceway.

* Limit for moment load is the maximum moment load that can be applied to the output shaft, within which basic performance is maintained and operation is possible.

* Moment stiffness shows the reference values. The lower limit value is approximately 80% of the displayed value.

Lubrication

The standard lubrication method for the CSF-mini series is grease lubrication. The product is shipped while the grease is sealed, and adding or application of the grease is not required when installing the product. The following grease is used as the lubrication agent.

Lubrication part	Speed reducer	Main bearing
Lubrication agent to be used	Harmonic Grease® SK-2	Multemp HL-D
Manufacturers	Harmonic Drive Systems Inc.	Kyodo Yushi Co.,Ltd.
Base oil	Purified mineral oil	Synthetic hydrocarbon oil
Thickener	Lithium soap base	Lithium soap base
Mixing consistency (25°C) (Equivalent NLGI consistency No.)	265 to 295 (No.2)	265 to 295 (No.2)
Drop point	198°C	210°C
Appearance	Green	White

Mechanical accuracy

The CSF-mini series uses the high-precision 4-point contact ball bearing for the main bearing to achieve high mechanical accuracy of the output part. The mechanical accuracies of the output shaft and output flange are shown below.

[Unit: mm]

Symbol	Accuracy Item	Size 7	
		2XH-J	2XH-F
a	Output shaft tip runout	0.030	-
	Output shaft inside diameter runout	-	0.005
b	Installation spigot concentricity	0.040	
c	Installation surface squareness	0.020	
d	Output flange runout	0.005	
e	Parallelism between the installation surface and output flange	0.018	

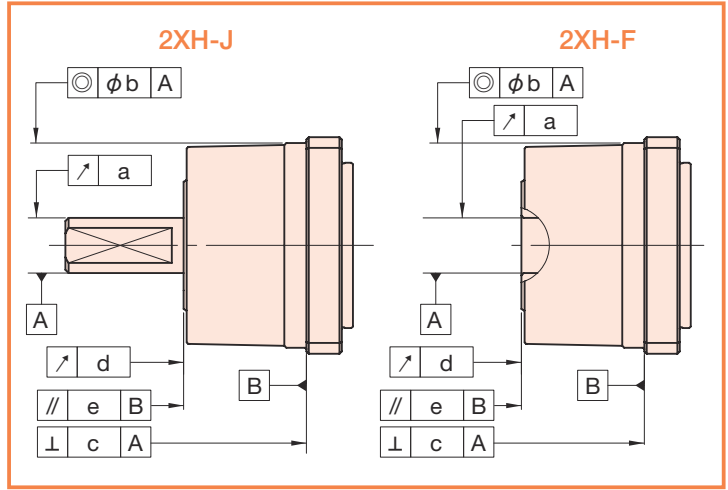

Installation Accuracy

When installing, ensure that you retain the recommended accuracy shown below in order to fully realize the excellent performance of the CSF-mini series.

[Unit: mm]

Symbol	Accuracy Item	Size
		7
a	Case mating face squareness	0.008
b	Wave generator mounted surface	0.005
c	Input shaft concentricity	0.005

Recommended installation accuracy

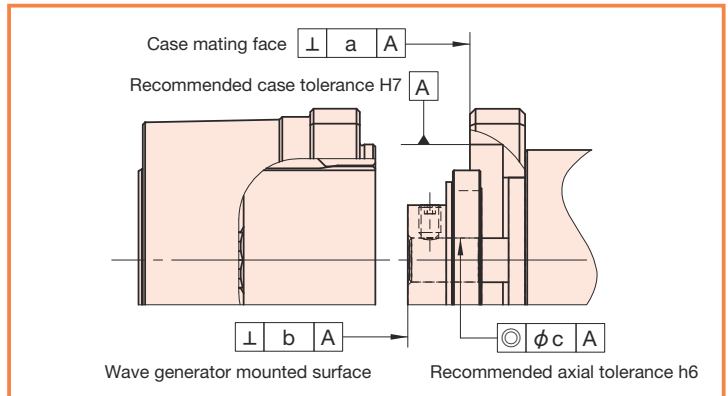

Installation and transmission torque

Installation to the device

When installing the CSF-mini series to the device, check the flatness of the installation surface and check for any burrs around the tap, and fix the mounting flange with bolts.

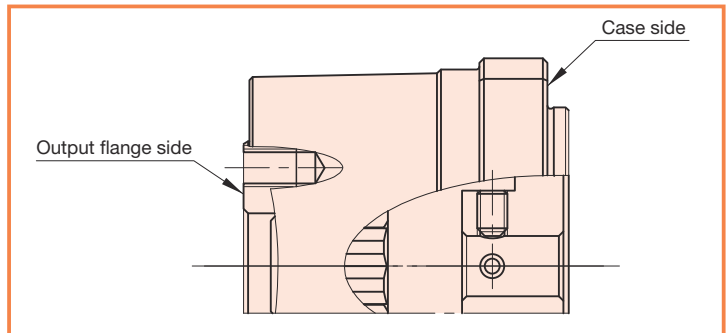

Case side installation and transmission torque

(a-b equally-distributed part and c-d equally-distributed part in the P3 Outline drawing)

Item	Size	7
Number of bolts		2
Bolt size		M2.5
Mounting P.C.D	mm	31.5
	N-m	0.49
Bolt tightening torque	kgf-m	0.050
	mm	3.0
Thread fit minimum length	N-m	3.8
	kgf-m	0.39

* Recommended bolt name: JIS B 1176 Hexagon socket head bolt (Strength classification: 12.9 or higher in JIS B 1051)

* Torque coefficient: K=0.2, tightening coefficient: A=1.4, Friction coefficient of the joining surfaces: $\mu=0.15$

* Use washers to avoid direct contact with the bolt seat on the aluminum.

* When using two tap holes of the case, the recommended drill hole diameter on the other side is $\phi 3.0$ (positional tolerance of $\phi 0.25$).

Output flange side installation and transmission torque

(x-y equally-distributed part in the P3 Outline drawing)

Item	Size	7
Number of bolts		4
Bolt size		M2.5
Mounting P.C.D	mm	13
	N-m	1.1
Bolt tightening torque	kgf-m	0.11
	N-m	7.2
Bolt transmission torque	kgf-m	0.73

* Recommended bolt name: JIS B 1176 Hexagon socket head bolt (Strength classification: 12.9 or higher in JIS B 1051)

* Torque coefficient: K=0.2, tightening coefficient: A=1.4, Friction coefficient of the joining surfaces: $\mu=0.15$

* When installing pulleys and pinions for shaft output, do not apply any shock to the output shaft. Doing so may cause deterioration of precision or failure of the speed reducer.

Operational precautions

Use only in a specified environment.

Please ensure the following environmental conditions are complied with:

● Ambient temperature 0 to 40°C ● No splashing of water or oil ● Do not expose to corrosive or explosive gas ● No dust such as metal powder

* For other precautions and warranty, refer to the Harmonic Drive® General Catalog.



Information desk for urgent repair and inquiry [Information desk for urgent repair request and technical consultation]

• **TEL: CS department 0263 (83) 6812**

• Business hours: Monday ~ Friday 9:00-12:00 13:00-17:00 (Except Saturdays, Sundays, national holidays and our specified days off)

■ Please contact our sales department with any questions.

Head Office

Ichigo Omori Building, 6-25-3 Minami-Oi,
Shinagawa-ku, Tokyo 140-0013 JAPAN
Phone: +81-3-5471-7800 / FAX: +81-3-5471-7811

Tokyo Office

Ichigo Omori Building, 6-25-3 Minami-Oi,
Shinagawa-ku, Tokyo 140-0013 JAPAN
Phone: +81-3-5471-7830 / FAX: +81-3-5471-7836

Tokyo Office, Kitakanto Team

Ichigo Omori Building, 6-25-3 Minami-Oi,
Shinagawa-ku, Tokyo 140-0013 JAPAN
Phone: +81-3-6410-8485 / FAX: +81-3-6410-8486

Koshin Office

5103-1 Hotakaariake, Azumino-shi, Nagano
399-8301 JAPAN
Phone: +81-263-81-5940 / FAX: +81-263-50-5010

Chubu Office

TM21-2F, 21 Terugaoka, Meito-ku, Nagoya-shi,
Aichi 465-0042 JAPAN
Phone: +81-52-773-7451 / FAX: +81-52-773-7462

Kansai Office

Shin-Osaka Ueno Toyo Building 3F, 7-4-17 Nishi-nakajima,
Yodogawa-ku, Osaka-shi, Osaka 532-0011 JAPAN
Phone: +81-6-6885-5720 / FAX: +81-6-6885-5725

Kyushu Office

NMF Hakata-ekimae Building 7F, 1-15-20 Hakata-ekimae,
Hakata-ku, Fukuoka-shi, Fukuoka 812-0011 JAPAN
Phone: +81-92-451-7208 / FAX: +81-92-481-2493

Overseas Division

5103-1 Hotakaariake, Azumino-shi, Nagano
399-8301 JAPAN
Phone: +81-263-81-5950 / FAX: +81-263-50-5010

Hataka Plant

1856-1 Hotakamaki, Azumino-shi, Nagano
399-8305 JAPAN
Phone: +81-263-83-6800 / FAX: +81-263-83-6901

"HarmonicDrive" is a trademark of Harmonic Drive Systems Inc.

The academic or generic term of our "HarmonicDrive" products is "strain wave gearing".

The company name and Product name described in this document are generally registered trademarks or trademarks of each company.

<https://www.hds.co.jp/>



Registered Trademark in Japan