

HarmonicDrive® compact variation

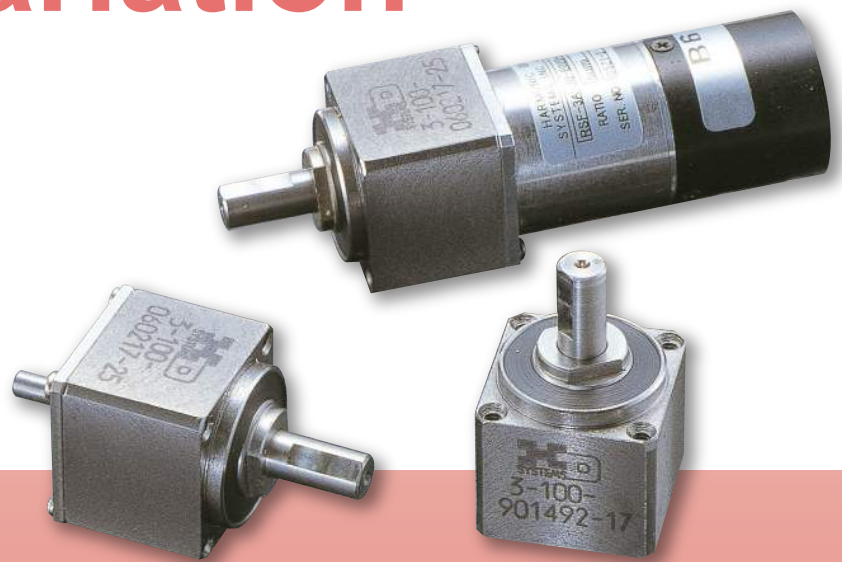

HarmonicDrive® mini series Product Guide

The HarmonicDrive® mini series promises higher torque and accurate positioning regardless of its compact size and light weight.

HarmonicDrive® is known as strain wave gearing, and the biggest feature is that it incorporates only three basic components to easily enable a reduction in the size and weight the device. In addition, the number of meshing teeth is large, and high torque is generated to enable a highly accurate positioning.

While utilizing the original characteristics of the product, reduction in the size of HarmonicDrive® has been advanced on the development theme of further compactness and lighter weight.

The Harmonic Drive® mini series contributes to a reduction in the size and footprint of each device, and achieves a higher level of motion control.

Structure and operation principle



Wave generator

The wave generator consists of the thin ball and bearing that fit into the outer circumference of the elliptical cam. The inner ring of the bearing is fixed to the cam, while the outer ring deforms elastically via the ball. Normally, this is installed to the input shaft.

Flex spline

This is the thin, cup-like, metallic, and elastic body. The outer circumference of the opening has the teeth. The bottom of the flex spline (bottom of the cup shape) is referred to as the diaphragm, and is installed to the output shaft in the normal fashion.

Circular spline

This is the rigid and ring-shape component. The inner circumference has the teeth, and the number of teeth is higher than the flex spline by two teeth. Normally, it is fixed to the casing.

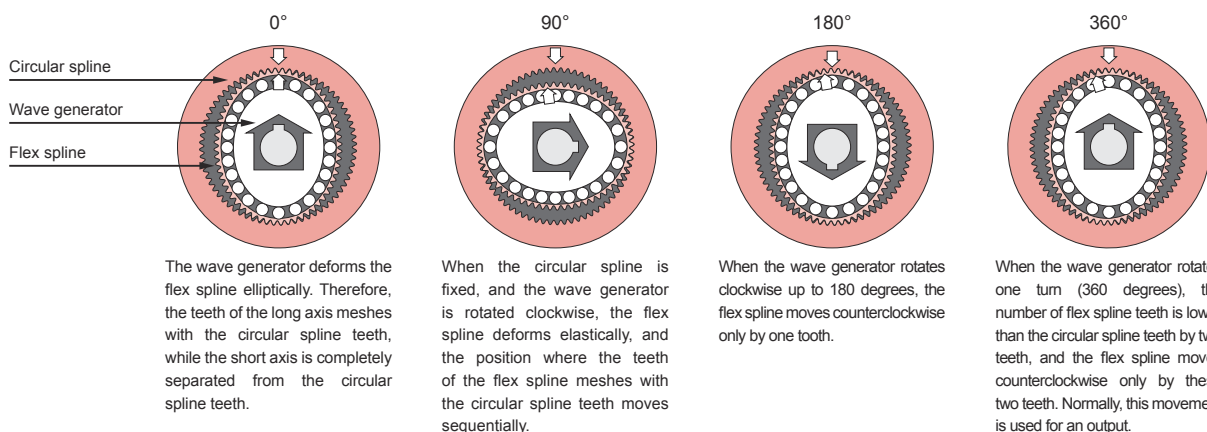

Precision-control speed reducer HarmonicDrive®

CSF-mini series ultra-flat/high-stiffness type



The lightweight, ultra-flat, high-stiffness type has been developed based on the CSF-mini series in which small models of HarmonicDrive® are unitized. Compared with the conventional CSF-mini series, the overall length has been greatly flattened, and high stiffness has been achieved by using the crossed roller bearing as the main bearing of the output part.

Please consider using this product for compact/lightweight portable robots or for the mechanical parts of compact devices or machines.



Example of motor installation

CSF supermini series ultra-compact type CSF-mini series compact type



CSF supermini



CSF-mini

CSF supermini / CSF-mini series is a product in which the smallest models of HarmonicDrive® are unitized in a user-friendly manner.

The “compact four-point contact ball bearing” that has been developed uniquely by HDS is used as the main bearing to enable direct support of the external load.

The gear head type to be installed directly to servo motors, the double-shaft unit type that has input and output shafts, and other types are available. Select the optimum model according to the design needs of the machines and devices.

Precision-control speed reducer HarmonicDrive®

AC servo actuator FHA-C mini series



This is the AC servo actuator consisting of HarmonicDrive® integrated with a compact/flat AC servo actuator. This actuator has a uniquely compact shape and a hollow structure that penetrates through the actuator located at the center. By passing the wire, pipe, laser light, and others through the actuator, machines and devices can be simplified. You can select the built-in encoder from the incremental and absolute types. Combination with the dedicated driver achieves even more accurate control.

AC servo actuator RSF supermini series



The RSF supermini series is a compact, high-torque, high-rotational accuracy AC servo actuator consisting of a precision-control speed reducer HarmonicDrive® combined with an AC servo motor. In RSF-5B, an actuator equipped with a brake is provided as the standard product lineup. The AC servo driver HA-680 dedicated for 24-VDC power supply fully brings out the performance of this AC servo actuator. A set of this AC servo actuator and driver achieves high-rotational accuracy, compact machines and devices.

HarmonicDrive® CSF-mini series ultra-flat/high-stiffness type



Features

- The ultra-flat structure can provide a design whereby the size of a machine or device can be reduced.
- The high-stiffness crossed roller bearing can support the external load directly.
- An installation flange tailored to the motor used by a customer is also available.

Rating Table

Model no.	Reduction ratio	Rated torque at input speed 2000 r/min	Limit for repeated peak torque	Limit for average torque	Limit for Momentary Peak Torque	Allowable maximum input speed	Allowable average input speed	Moment of Inertia (1/4GD ²)
		Nm	Nm	Nm	Nm	r/min	r/min	kgcm ²
8	30	0.9	1.8	1.4	3.3	8500	3500	4.0 x 10 ⁻³
	50	1.8	3.3	2.3	6.6			
	100	2.4	4.8	3.3	9.0			
11	30	2.2	4.5	3.4	8.5	8500	3500	1.5 x 10 ⁻²
	50	3.5	8.3	5.5	17			
	100	5.0	11	8.9	25			
14	30	4.0	9.0	6.8	17	8500	3500	4.0 x 10 ⁻²
	50	5.4	18	6.9	35			
	100	7.8	28	11	54			

External dimension drawing

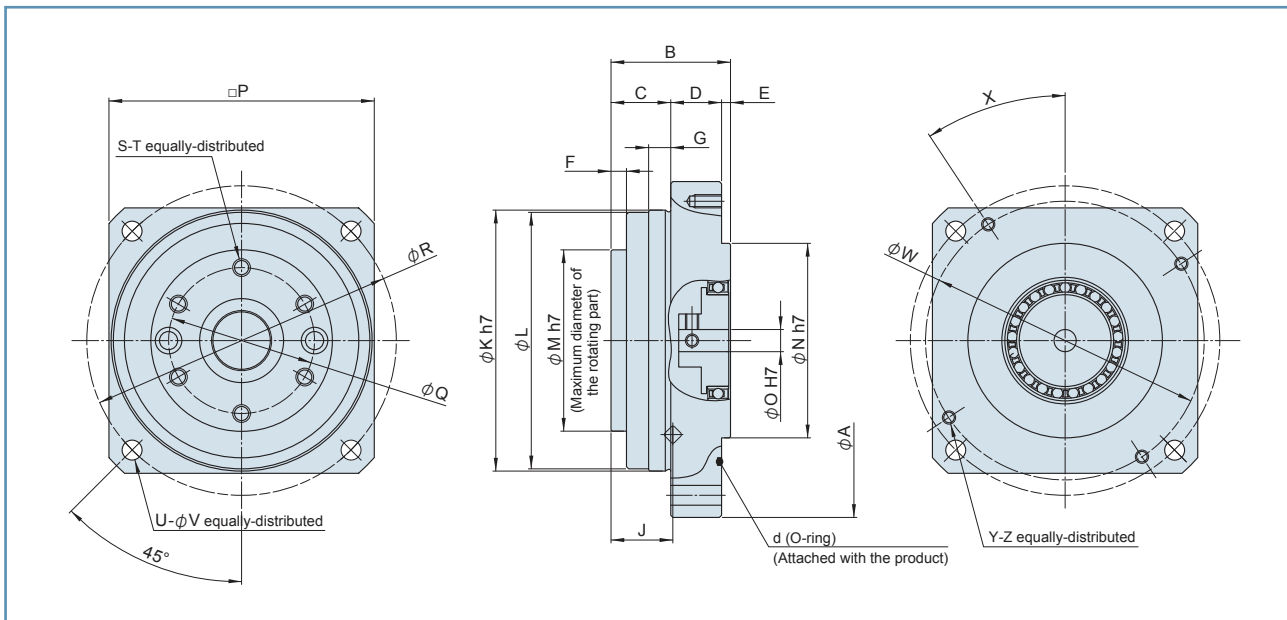

Dimension table

Unit: mm

Model no.	φA	B	C	D	E	F	G	J	φK	φL	φM	φN	φO	□P
8	66	24.8	13	9	2.8	3	5	12.9	49	48	33.5	30	5	50±1
11	80	27	13.5	11.5	2	3.5	5	14	59	58	41	44	5	60±1
14	100	33.5	18.5	12	3	3.5	8	14	74	73	52.5	52	8	75±1

Model no.	φQ	φR	S	T	U	φV	φW	X	Y	Z	d	Weight (g)
8	25.5	58	6	M3 x 6	4	3.5	52	35 °	4	M3 x 5	φ29.8 x 0.8	200
11	33	70	6	M4 x 5	4	4.5	63	33.5 °	4	M3 x 6	φ54.0 x 1.2	330
14	44	88	6	M5 x 7	4	5.5	70.71	55 °	4	M4 x 8	φ58.4 x 1.3	620

HarmonicDrive[®] CSF supermini series ultra-compact type

Features

- Compact and lightweight (smallest model)
- Compact and simple design
- High torque capacity
- High stiffness
- No backlash
- Advanced positioning accuracy and rotational accuracy
- The input and output shafts coexist.

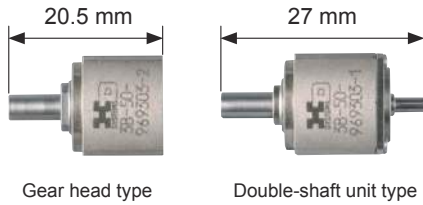

Rating Table

Model no.	Reduction ratio	Rated torque at input speed 2000 r/min		Limit for repeated peak torque		Limit for average torque		Limit for Momentary Peak Torque		Allowable maximum input speed	Allowable average input speed	Moment of Inertia (1/4GD ²)
		Nm	kgfm	Nm	kgfm	Nm	kgfm	Nm	kgfm	r/min	r/min	kgcm ²
3	30	0.06	0.006	0.13	0.013	0.10	0.010	0.22	0.022	10000	6500	1U: 5.3 x 10 ⁻⁷ 1U-CC: 7.0 x 10 ⁻⁷
	50	0.11	0.011	0.21	0.021	0.13	0.013	0.41	0.040			
	100	0.15	0.015	0.30	0.029	0.23	0.023	0.57	0.056			

* The value in the upper column of the moment of inertia is for the 1U type, while the value in the lower column is for the 1U-CC type.

External dimension drawing

Unit: mm

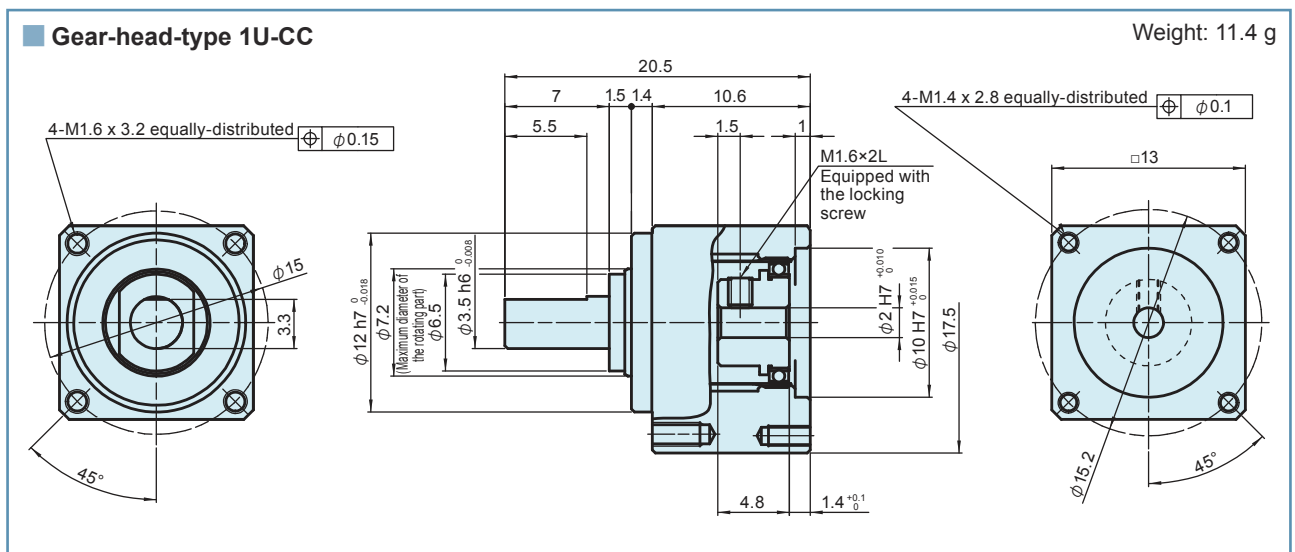
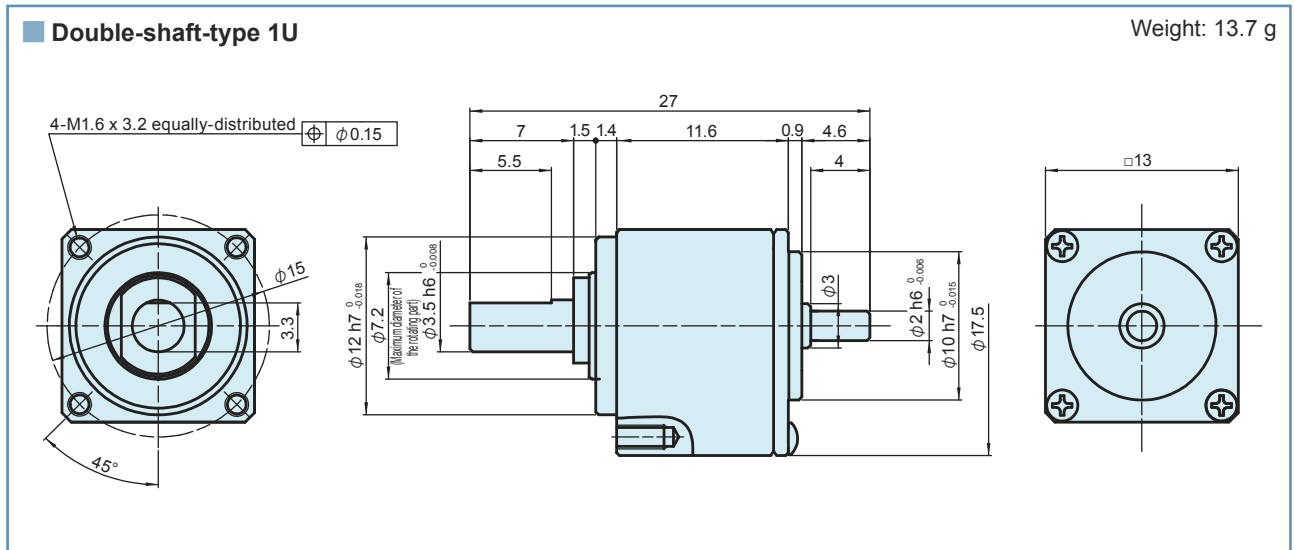

* For details of the dimensions and shape, refer to the delivery specification drawing.
 * The tolerance varies depending on the manufacturing method (casting or machining) of the parts. For the tolerance, contact us as required.

HarmonicDrive® CSF-mini series compact type

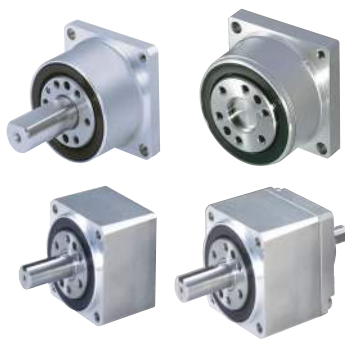

Features

- Compact and lightweight
- Compact and simple design
- High torque capacity
- High stiffness
- No backlash
- Advanced positioning accuracy and speed accuracy
- The input and output shafts coexist.

Rating Table

Model no.	Reduction ratio	Rated torque at input speed 2000 r/min	Limit for repeated peak torque	Limit for average torque	Limit for Momentary Peak Torque	Allowable maximum input speed	Allowable average input speed	Moment of Inertia (1/4GD ²)
		Nm	Nm	Nm	Nm	r/min	r/min	kgcm ²
5	30	0.25	0.5	0.38	0.9	10000	6500	2.5 x 10 ⁻⁴ 2.5 x 10 ⁻⁴
	50	0.4	0.9	0.53	1.8			
	100	0.6	1.4	0.94	2.7			
8	30	0.9	1.8	1.4	3.3	8500	3500	3.2 x 10 ⁻³ 3.0 x 10 ⁻³
	50	1.8	3.3	2.3	6.6			
	100	2.4	4.8	3.3	9.0			
11	30	2.2	4.5	3.4	8.5	8500	3500	1.4 x 10 ⁻² 1.2 x 10 ⁻²
	50	3.5	8.3	5.5	17			
	100	5.0	11	8.9	25			

* The value in the upper column of the moment of inertia is for the 1U type, while the value in the lower column is for the 2XH type.

1U type
(Double-shaft unit)

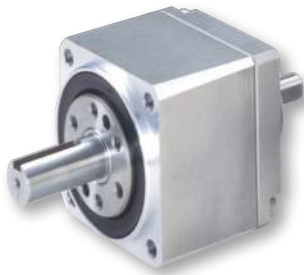

1U-CC type
(Unit without a shaft on the input side)

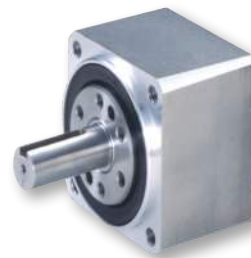

2XH-F type (Flange gear head on the output side) **2XH-J type** (Gear head equipped with a shaft on the output side)



External dimension drawing Double-shaft unit type

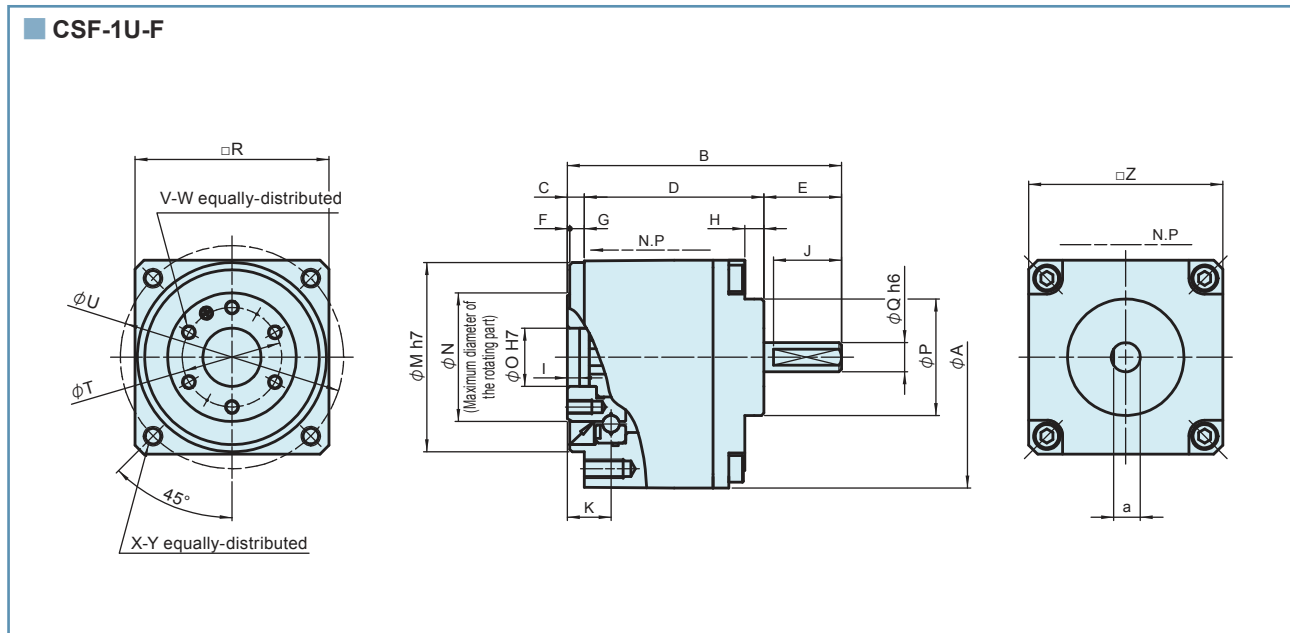
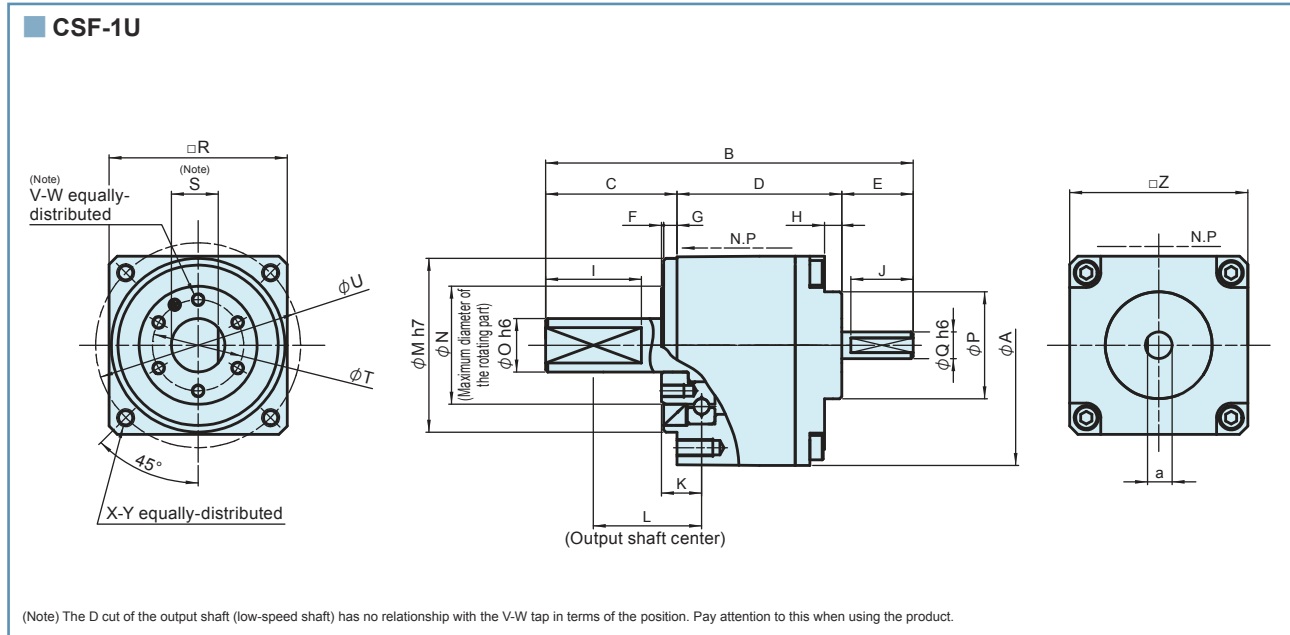

* For details of the dimensions and shape, refer to the delivery specification drawing.
 * The tolerance varies depending on the manufacturing method (casting or machining) of the parts. For the dimensions without the tolerance, contact us as required.

Dimension table

CSF-1U

Unit: mm

Model no.	ϕA	B	C	D	E	F	G	H	I	J	K	L	ϕM h7	ϕN	ϕO h6	ϕP
5	26.5	37	13	16	8	0.5	2.5	0.8	9	7	4.85	9.85	19.5	13	5	9
8	40	65.5	23	29.5	13	0.5	2.5	2.6	18	11	7.3	17.3	29	20	9	16
11	54	82.5	29.5	37	16	0.5	3	3.9	21.5	14	9	22	39	26.5	12	24

Model no.	ϕQ h6	$\square R$	S	ϕT	ϕU	V	W	X	Y	$\square Z$	a	Weight (g)
5	3	20.4±0.42	4.6	9.8	23	3	M2 x 3	4	M2 x 3	20±0.42	2.6	35
8	5	30.7±0.46	8	15.5	35	4	M3 x 4	4	M3 x 6	30±0.46	4.5	130
11	6	40.9±0.50	10.5	20.5	46	6	M3 x 5	4	M4 x 8	40±0.50	5.5	240

CSF-1U-F

Unit: mm

Model no.	ϕA	B	C	D	E	F	G	H	I	J	K	ϕM h7	ϕN	ϕO H7	ϕP	ϕQ h6
5	26.5	27	3	16	8	0.5	2.5	0.8	1.7	7	4.85	19.5	13	5	9	3
8	40	45.5	3	29.5	13	0.5	2.5	2.6	2.2	11	7.3	29	20	9	16	5
11	54	56.5	3.5	37	16	0.5	3	3.9	2.5	14	9	39	26.5	12	24	6

Model no.	$\square R$	ϕT	ϕU	V	W	X	Y	$\square Z$	a	Weight (g)
5	20.4±0.42	9.8	23	3	M2 x 3	4	M2 x 3	20±0.42	2.6	34
8	30.7±0.46	15.5	35	4	M3 x 4	4	M3 x 6	30±0.46	4.5	120
11	40.9±0.5	20.5	46	6	M3 x 5	4	M4 x 8	40±0.5	5.5	220

External dimension drawing Unit without a shaft on the input side

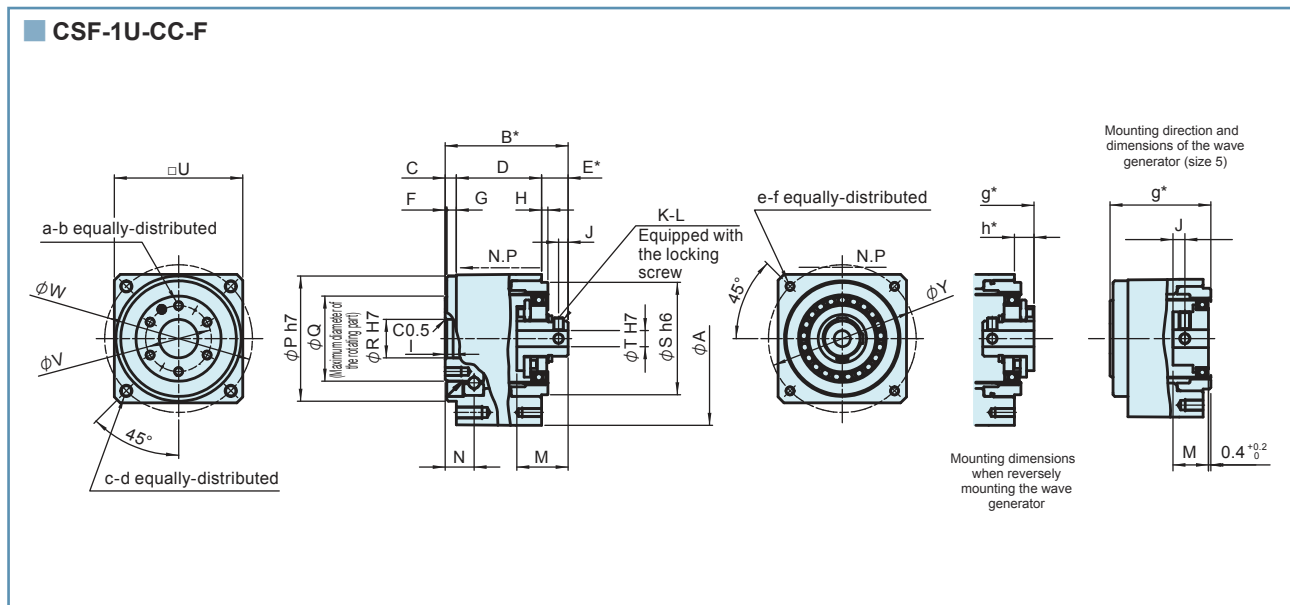
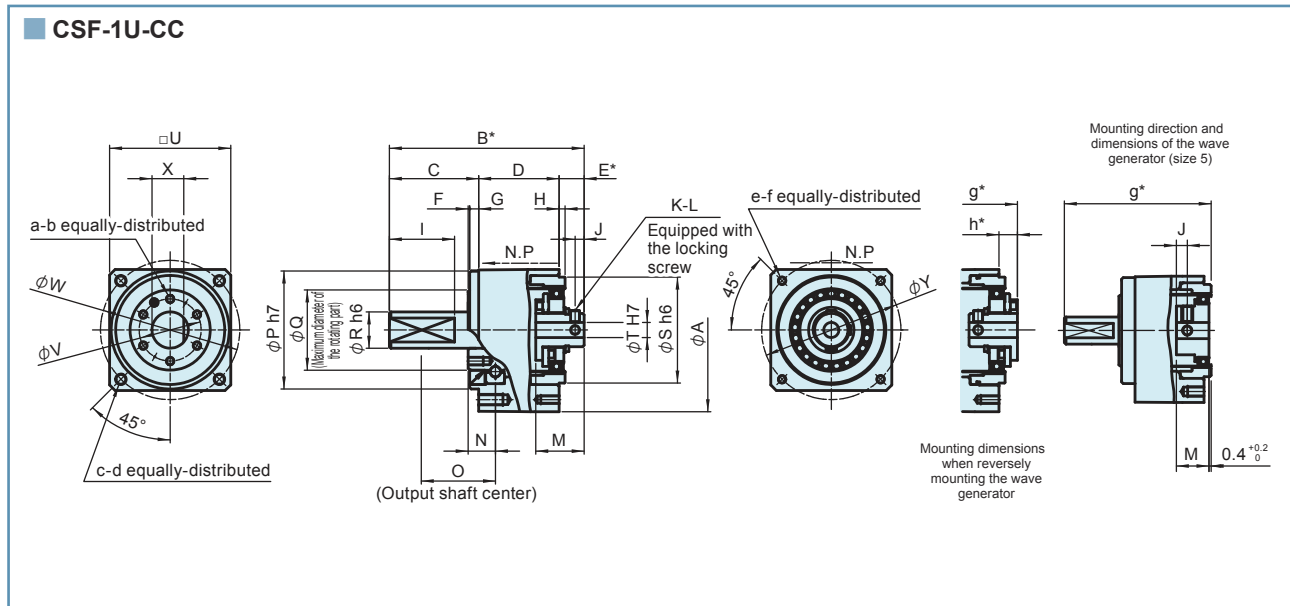

* For details of the dimensions and shape, refer to the delivery specification drawing.
 * The tolerance varies depending on the manufacturing method of the parts. For the dimensions without the tolerance, contact us as required.

Dimension table

CSF-1U-CC

Unit: mm

Model no.	ϕA	B^*	C	D	E^*	F	G	H	I	J	K	L	M	N	O	$\phi P h7$	ϕQ
5	26.5	30.5	13	12.7	$4.8^{0.2}_0$	0.5	2.5	1.3	9	2	2	M2 x 3	6	4.85	9.85	19.5	13
8	40	51	23	21.5	$6.5^{0.3}_0$	0.5	2.5	1.5	18	2	2	M2 x 3	12	7.3	17.3	29	20
11	54	64.3	29.5	26.5	$8.3^{0.7}_0$	0.5	3	2	21.5	3	2	M3 x 4	16	9	22	39	26.5

Model no.	$\phi R h6$	$\phi S h6$	$\phi T H7$	$\square U$	ϕV	ϕW	X	ϕY	a	b	c	d	e	f	g^*	h^*	Weight (g)
5	5	17	3	20.4 ± 0.42	9.8	23	4.6	22.5	3	M2 x 3	4	M2 x 3	4	M2 x 3	27	-	27
8	9	26	3	30.7 ± 0.46	15.5	35	8	34	4	M3 x 4	4	M3 x 6	4	M2.5 x 5	48.7	$4.2^{0.3}_0$	111
11	12	35	5	40.9 ± 0.5	20.5	46	10.5	46	6	M3 x 5	4	M4 x 8	4	M3 x 6	62.1	$6.1^{0.7}_0$	176

CSF-1U-CC-F

Model no.	ϕA	B^*	C	D	E^*	F	G	H	I	J	K	L	M	N	$\phi P h7$	ϕQ
5	26.5	20.5	3	12.7	$4.8^{0.2}_0$	0.5	2.5	1.3	1.7	2	2	M2 x 3	6	4.85	19.5	13
8	40	31	3	21.5	$6.5^{0.3}_0$	0.5	2.5	1.5	2.2	2	2	M2 x 3	12	7.3	29	20
11	54	38.3	3.5	26.5	$8.3^{0.7}_0$	0.5	3	2	2.5	3	2	M3 x 4	16	9	39	26.5

Model no.	$\phi R H7$	$\phi S h6$	$\phi T H7$	$\square U$	ϕV	ϕW	ϕY	a	b	c	d	e	f	g^*	h^*	Weight (g)
5	5	17	3	20.4 ± 0.42	9.8	23	22.5	3	M2 x 3	4	M2 x 3	4	M2 x 3	17	-	25
8	9	26	3	30.7 ± 0.46	15.5	35	34	4	M3 x 4	4	M3 x 6	4	M2.5 x 5	28.7	$4.2^{0.3}_0$	100
11	12	35	5	40.9 ± 0.5	20.5	46	46	6	M3 x 5	4	M4 x 8	4	M3 x 6	36.1	$6.1^{0.7}_0$	150

* The B, E, g, and h dimensions marked with * mean the mounting positions in the shaft direction and tolerance range of the three parts (wave generator, flex spline, and circular spline) that form HarmonicDrive®. These dimensions affect the performance and strength. Be sure to maintain these dimensions.
 * When the product is delivered, a wave generator is not incorporated.

External dimension drawing Gear head type

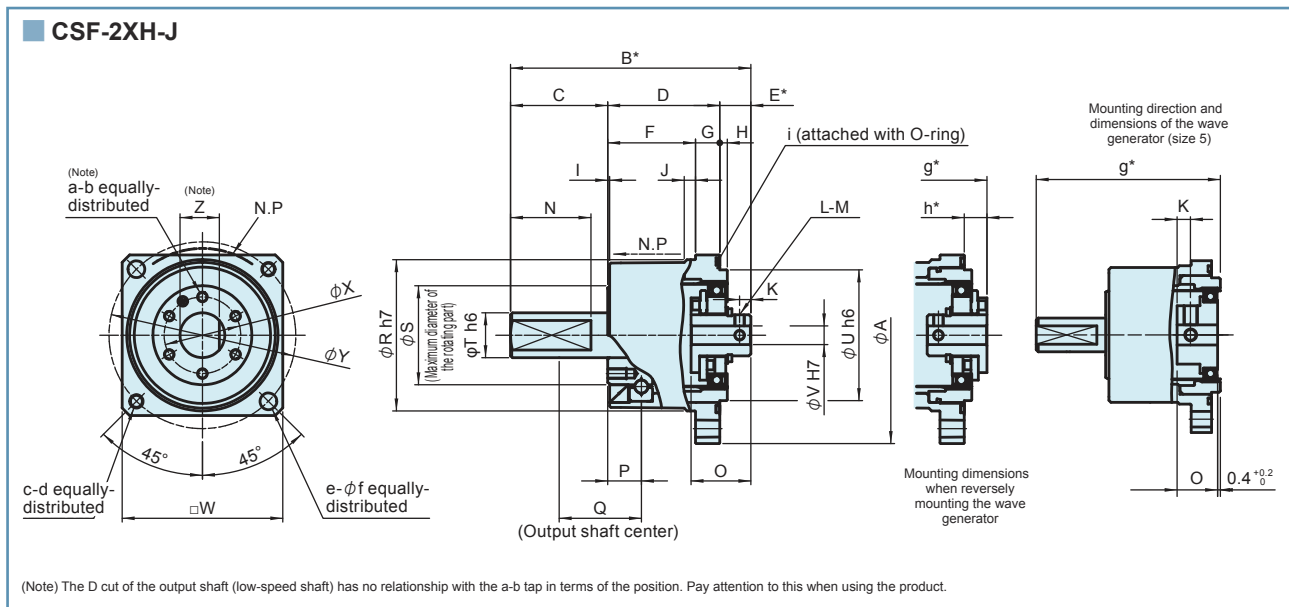
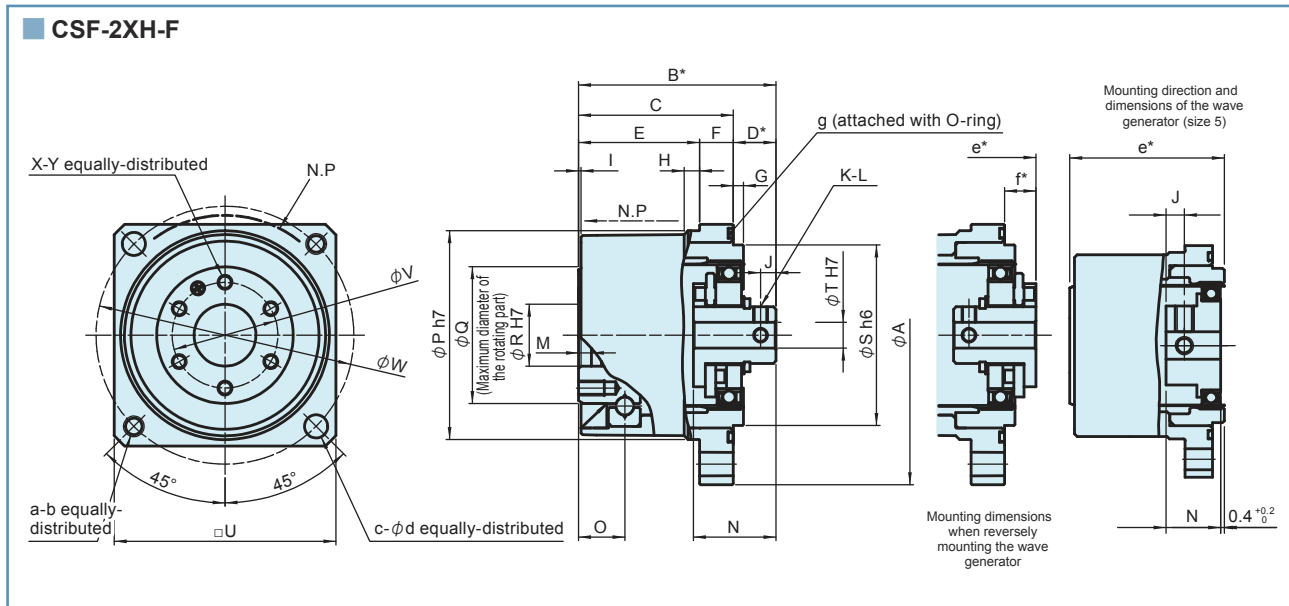

* For details of the dimensions and shape, refer to the delivery specification drawing.

* The tolerance varies depending on the manufacturing method (casting or machining) of the parts. For the dimensions without the tolerance, contact us as required.

Dimension table

CSF-2XH-F

Unit: mm

Model no.	φA	B*	C	D*	E	F	G	H	I	J	K	L	M	N	O	φP h7	φQ
5	29	20.5	15.7	4.8 ^{0.2} _{0.2}	12.7	3	1.3	2	0.5	2	2	M2 x 3	1.7	6	4.85	20.5	13
8	43.5	31	24.5	6.5 ^{0.3} _{0.3}	19	5.5	1.5	3	0.5	2	2	M2 x 3	2.2	12	7.3	31	20
11	58	38.3	30	8.3 ^{0.7} _{0.7}	23.5	6.5	2	3	0.5	3	2	M3 x 4	2.5	16	9	40.5	26.5
Model no.	φR H7	φS h6	φT H7	□U	φV	φW	X	Y	a	b	c	φd	e*	f*	g (Attached)	Weight (g)	
5	5	17	3	22±0.42	9.8	25	3	M2 x 3	2	M2	2	2.3	17	-	18.90 x 0.70	25	
8	9	26	3	32±0.46	15.5	37.5	4	M3 x 4	2	M3	2	3.4	28.7	4.2 ^{0.3} _{0.3}	28.20 x 1.00	100	
11	12	35	5	43±0.50	20.5	50	6	M3 x 5	2	M4	2	4.5	36.1	6.1 ^{0.7} _{0.7}	38.00 x 1.50	150	

CSF-2XH-J

Model no.	φA	B*	C	D	E*	F	G	H	I	J	K	L	M	N	O	P	Q	φR h7	φS
5	29	30.5	10	15.7	4.8 ^{0.2} _{0.2}	12.7	3	1.3	0.5	2	2	2	M2 x 3	9	6	4.85	9.85	20.5	13
8	43.5	51	20	24.5	6.5 ^{0.3} _{0.3}	19	5.5	1.5	0.5	3	2	2	M2 x 3	18	12	7.3	17.3	31	20
11	58	64.3	26	30	8.3 ^{0.7} _{0.7}	23.5	6.5	2	0.5	3	3	2	M3 x 4	21.5	16	9	22	40.5	26.5
Model no.	φT h6	φU h6	φV H7	□W	φX	φY	Z	a	b	c	d	e	φf	g*	h*	i (Attached)	Weight (g)		
5	5	17	3	22±0.42	9.8	25	4.6	3	M2 x 3	2	M2	2	2.3	27	-	18.90 x 0.70	27		
8	9	26	3	32±0.46	15.5	37.5	8	4	M3 x 4	2	M3	2	3.4	48.7	4.2 ^{0.3} _{0.3}	28.20 x 1.00	111		
11	12	35	5	43±0.50	20.5	50	10.5	6	M3 x 5	2	M4	2	4.5	62.1	6.1 ^{0.7} _{0.7}	38.00 x 1.50	176		

* The dimensions marked with * mean the mounting position in the shaft direction and tolerance range of the three parts (wave generator, flex spline, and circular spline) that form HarmonicDrive[®].

These dimensions affect the performance and strength. Be sure to maintain these dimensions.

* When the product is delivered, a wave generator is not incorporated.

HarmonicDrive® FHA-C mini series



Features

- **Thin shape**
A thin precision-control speed reducer HarmonicDrive® has been integrated with an ultra-flat AC servo motor uniquely developed by HDS to achieve provision of this series. This series achieves dramatic reduction in the size of a machine or device.
- **Hollow structure**
In this series, the wire, pipe, laser light, and others can be passed through the through hole at the center of the actuator, provide energy to the operation part of a machine or device, and receive the signals. In this way, the machine/device structure can be simplified. (The absolute encoder type does not have a hollow structure.)
- **High-output torque**
Compared with the thin precision-control speed reducer HarmonicDrive® and the motor direct drive of the same size, the output torque is very high.
- **High positioning accuracy**
The detector resolution (incremental encoder) is 8000 pulses per rotation (0.00045 degrees per pulse) and the one-way positional accuracy does not exceed 90 seconds or less (FHA-14C-100). These values indicate that the series features high accuracy.
- **High torsional stiffness**
The high-stiffness HarmonicDrive® CSF-mini series is used.

Specifications

Item		Model		FHA-8C			FHA-11C			FHA-14C		
				30	50	100	30	50	100	30	50	100
Maximum torque (Note) 2, 5	Nm			1.8	3.3	4.8	4.5	8.3	11	9.0 (8.5)	18 (15.5)	28
				0.18	0.34	0.49	0.46	0.85	1.1	0.92 (0.87)	1.8 (1.6)	2.9
Maximum speed	r/min			200	120	60	200	120	60	200	120	60
Torque constant	100 V 200 V	Nm/A		3.9	6.7	14	3.8	6.6	13	4.2	7.2	15
		Kgfm/A		0.4	0.68	1.4	0.39	0.67	1.4	0.43	0.74	1.5
	24 V	Nm/A		0.8	1.3	2.7	0.8	1.3	2.6	0.8	1.4	2.9
		Kgfm/A		0.08	0.13	0.28	0.08	0.13	0.27	0.08	0.14	0.30
Maximum current (Note) 2, 5	100 V/200 V	A		0.61	0.64	0.48	1.5	1.6	1.1	2.9	3.2	2.4
	24 V	A		3.0	3.3	2.4	7.8	8.2	5.6	14.8 (14.1)	16.4 (14.1)	12.3
Moment of inertia (Note) 3	INC	GD ² /4	kgm ²	0.0026	0.0074	0.029	0.0060	0.017	0.067	0.018	0.050	0.20
		J	kgfcm ²	0.027	0.075	0.30	0.061	0.17	0.68	0.18	0.51	2.0
	ABS	GD ² /4	kgm ²	0.0026	0.0073	0.029	0.0062	0.017	0.069	0.019	0.054	0.215
		J	kgfcm ²	0.027	0.0747	0.298	0.063	0.176	0.705	0.197	0.547	2.189
Reduction ratio			30	50	100	30	50	100	30	50	100	
Allowable moment load	Nm		15			40			75			
	kgfm		1.5			4.1			7.7			
Moment Stiffness	Nm/rad		2 x 10 ⁴			4 x 10 ⁴			8 x 10 ⁴			
	kgfm/arc-min		0.59			1.2			2.4			
Output shaft resolution (Multiplied by four) (Note) 4	INC	pls/rev	240,000	400,000	800,000	240,000	400,000	800,000	240,000	400,000	800,000	
	ABS	pls/rev	3,932,160	6,553,600	13,107,200	3,932,160	6,553,600	13,107,200	3,932,160	6,553,600	13,107,200	
Input power supply voltage	V		24 VDC, 100 VAC, or 200 VAC									
Mass	INC	kg	0.40			0.62			1.2			
	ABS	kg	0.50			0.75			1.3			
Protective structure			Totally enclosed self-cooled type									
Ambient environment specification			Use temperature: 0 to 40°C/Storage temperature: -20 to +60°C, Use humidity and storage humidity: 20 to 80%RH (non-condensing) Free from dust, dirt, metallic powder, corrosive gas, flammable gas, oil mist, and others. Avoid outdoor use or direct sunlight. Altitude: 1,000 m or less Insulation resistance: 100 MΩ (500 VDC) or higher Dielectric strength voltage: 1500 VAC/min Insulation class: B Absolute encoder magnetic noise resistance: 0.01 tesla									
Mounting direction			Can be installed in any direction.									
Safety standard			CE mark									
Combined servo driver	100 V/200 V		HA-800-1									
	24 V (INC)		HA-680-4-24						HA-680-6-24			
	24 V (ABS)		RF2H21A0AHD manufactured by SANYO DENKI									

(Note) 1. The values in the table above show typical values for the output shaft.
 2. The values are obtained when HA-800 or HA-680 is combined with the RF2H21A0AHD servo driver manufactured by SANYO DENKI.
 3. The moment of inertia is obtained by converting the total values of the moment of inertia of the motor shaft and HarmonicDrive® into that of the output shaft.
 4. The output shaft resolution for the incremental encoder is obtained by (Motor shaft encoder resolution multiplied by four) x (Reduction ratio), while that for the absolute encoder is obtained by (Motor shaft encoder resolution) x (Reduction ratio).
 5. The value in () is obtained when combining with the RF2H21A0AHD manufactured by SANYO DENKI.
 6. For the actuator rotating direction, refer to the technical material.
 7. INC means the incremental encoder, while ABS means the absolute encoder.

External dimension drawing (incremental encoder type)

Unit: mm

Lead wire of the motor and encoder
(common to all models)

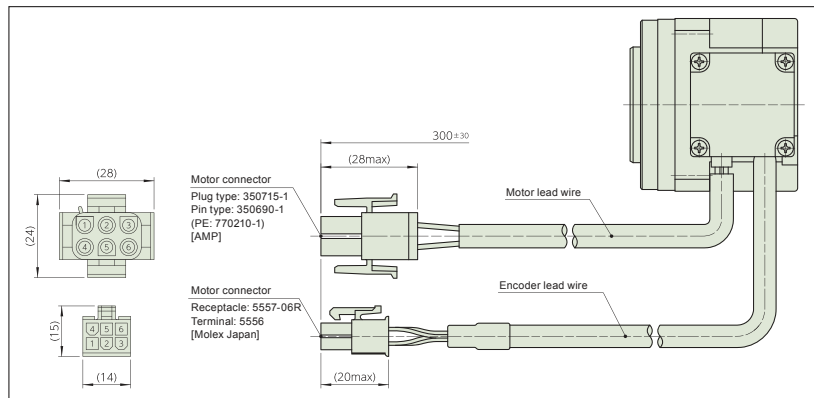

FHA-8C

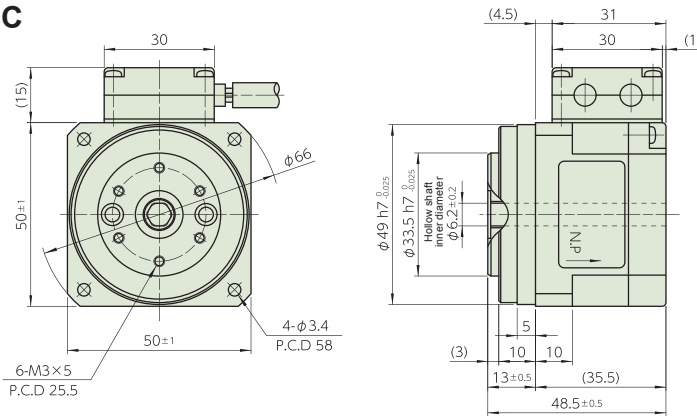

FHA-11C

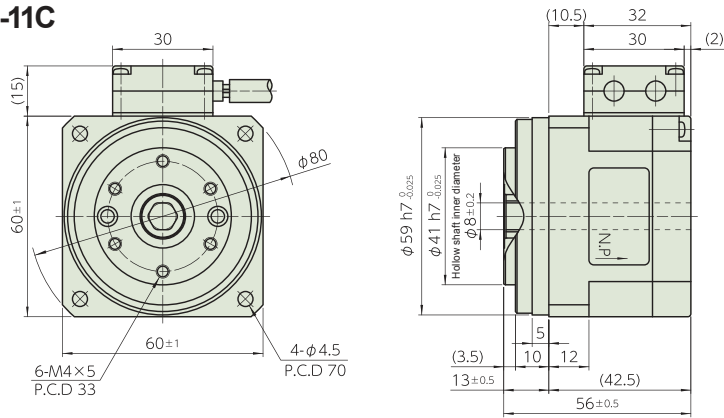

FHA-14C

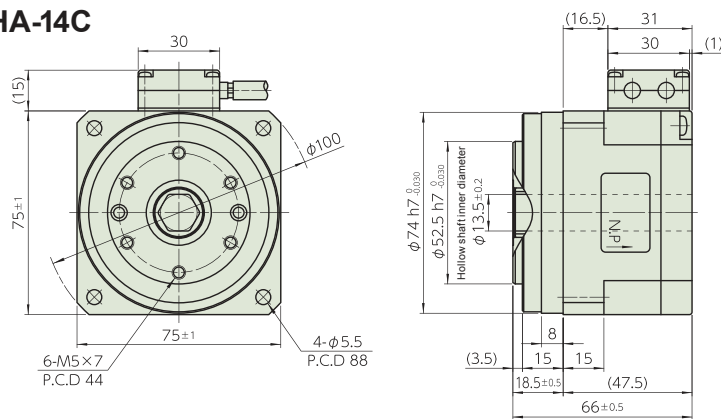

* For details of the dimensions and shape, refer to the delivery specification drawing issued by Harmonic Drive Systems.

* The tolerance varies depending on the manufacturing method (casting or machining) of the parts. For the dimensions without the tolerance, contact us.

External dimension drawing (absolute encoder type)

Unit: mm

Lead wire of the motor and encoder
(common to all models)

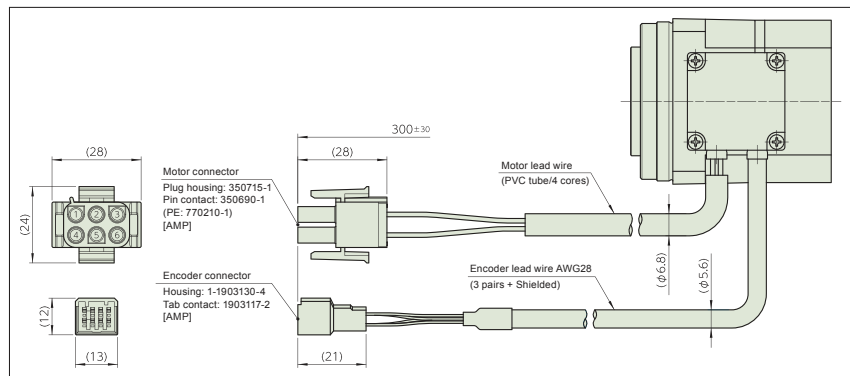

FHA-8C

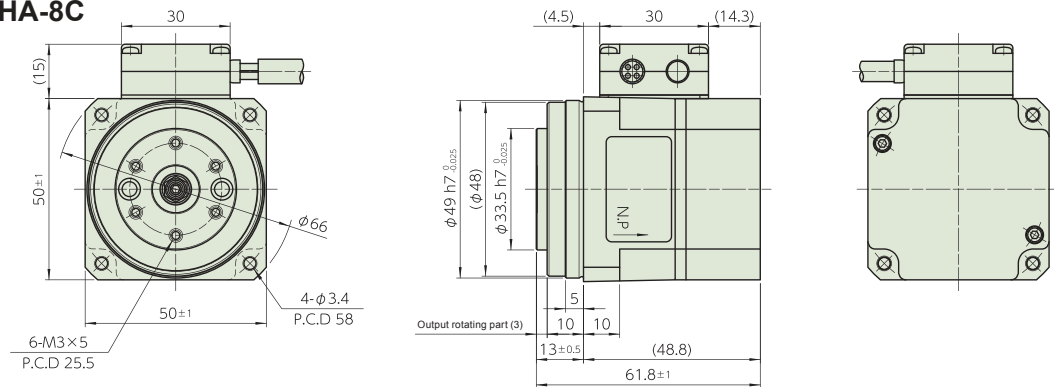

FHA-11C

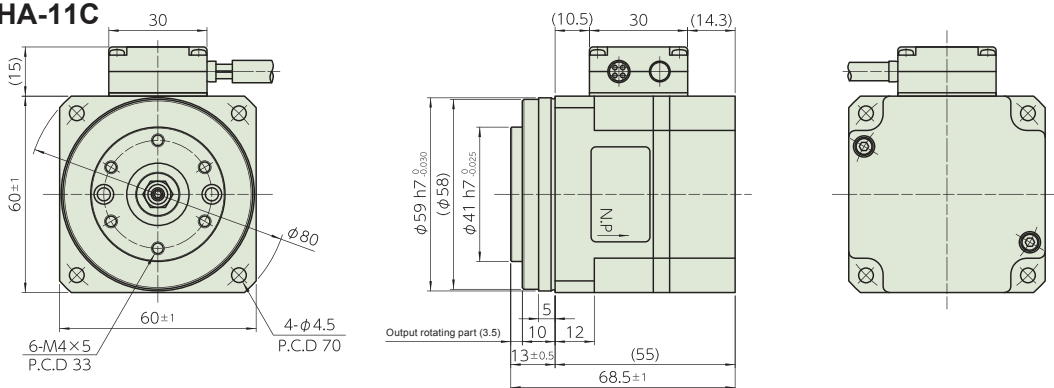

FHA-14C

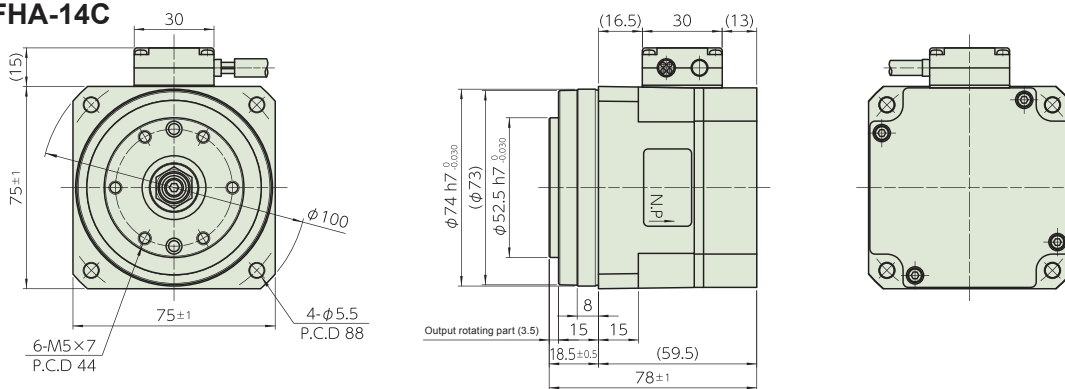

* For details of the dimensions and shape, refer to the delivery specification drawing issued by Harmonic Drive Systems.

* The tolerance varies depending on the manufacturing method (casting or machining) of the parts. For the dimensions without the tolerance, contact us.

HarmonicDrive® RSF supermini series



Features

- **Compact, lightweight, high torque**
The RSF supermini series that incorporates the precision-control speed reducer HarmonicDrive® features higher torque due to the very high output torque for the external dimensions compared with the system driven directly only by a high-capacity motor. In addition, combination with the dedicated AC servo motor achieves a greater than ever reduction in size and weight.
- **Advanced positioning accuracy**
The small backlash and advanced positioning accuracy as features of the precision-control speed reducer HarmonicDrive® achieve a high-precision mechanism.
- **Stable control performance**
The high reduction ratio of the precision-control speed reducer HarmonicDrive® secures stable control performance against variation of the moment of inertia of a large load.
- **Wider operating range**
The developed servo motor increases the maximum speed only of the motor up to 10000 r/min. This increase can expand the actuator operating range.

Specifications

Item		Model	RSF-3C			RSF-5B		
			30	50	100	30	50	100
Input power supply voltage (driver)	V	DC24±10 %						
Allowable continuous current	A	0.65	0.66	0.56	1.11	0.92	0.76	
Allowable continuous torque (When running at the allowable continuous speed)	Nm	0.03	0.07	0.11	0.18	0.29	0.44	
	kgfcm	0.31	0.68	1.08	1.83	2.95	4.48	
Allowable continuous speed (output shaft)	r/min	150	90	45	150	90	45	
Allowable continuous stall torque	Nm	0.04	0.08	0.12	0.28	0.44	0.65	
	kgfcm	0.41	0.82	1.22	2.85	4.48	6.62	
Instantaneous maximum current	A	1.5	1.4	1.1	2.3	2.2	1.7	
Maximum torque	Nm	0.13	0.21	0.3	0.5	0.9	1.4	
	kgfcm	1.27	2.05	2.94	5.10	9.17	14.3	
Maximum speed	r/min	333	200	100	333	200	100	
Torque constant	Nm/A	0.11	0.18	0.40	0.30	0.54	1.1	
	Kgfcm/A	1.12	1.84	4.08	3.06	5.51	11.22	
Inductive voltage constant	V/(r/min)	0.015	0.025	0.050	0.04	0.07	0.13	
Phase resistance (at 20°C)	Ω	1.34			0.82			
Phase inductance	mH	0.18			0.27			
Moment of inertia (Note) 3	GD ² /4	kgm ²	0.11 x 10 ⁻⁴	0.29 x 10 ⁻⁴	1.17 x 10 ⁻⁴	0.66 x 10 ⁻⁴ (0.11 x 10 ⁻³)	1.83 x 10 ⁻⁴ (0.31 x 10 ⁻³)	7.31 x 10 ⁻⁴ (1.23 x 10 ⁻³)
	J	kgfcm ²	1.07 x 10 ⁻⁴	2.98 x 10 ⁻⁴	11.90 x 10 ⁻⁴	0.67 x 10 ⁻³ (1.13 x 10 ⁻³)	1.87 x 10 ⁻³ (3.15 x 10 ⁻³)	7.45 x 10 ⁻³ (12.6 x 10 ⁻³)
Reduction ratio		30	50	100	30	50	100	
Allowable radial load (Output shaft center value)	N	36			90			
	kgf	3.6			9.1			
Allowable thrust load	N	130			270			
	kgf	13.2			27.5			
Encoder pulse count (motor shaft)	pls	200			500			
Encoder resolution (Output shaft: Multiplied by 4)(Note) 4	pls/rev	24,000	40,000	80,000	60,000	100,000	200,000	
Motor shaft brake	Input power supply voltage	V	-			DC24±10 %		
	Holding torque	Nm	-			0.18	0.29	0.44
kgfcm		-			1.83	2.95	4.48	
Weight (Note) 5	Without a brake	g	31.0 (excluding the clamp filter)			66.0 (excluding the clamp filter)		
	Equipped with a brake	g	-			86.0 (excluding the clamp filter)		
Protective structure		Totally enclosed self-cooled type						
Ambient environment specification		Use temperature: 0 to 40°C/Storage temperature: -20 to +60°C, Use humidity and storage humidity: 20 to 80%RH (non-condensing) Insulation resistance: 100 MΩ (500 VDC) or higher Dielectric strength voltage: 500 VAC/min Insulation class: B Time rating: Continuous Energization method: Permanent magnet type						
Combined servo driver		HA-680-4B-24			HA-680-4B-24			

(Note) 1. The values in the table above show typical values for the output shaft.
 2. The values in the table above are obtained when combining with the driver (HA-680-4B-24).
 3. The moment of inertia is obtained by converting the total values of the moment of inertia of the motor shaft and HarmonicDrive® into that on the output shaft side. The value in () is for the type equipped with a brake.
 4. The encoder resolution is obtained by (Motor shaft encoder resolution multiplied by four) x (Reduction ratio).
 5. The weight of the clamp filter is 6 g per unit.
 6. For the actuator rotating direction, refer to the technical material.

External dimension drawing

Unit: mm

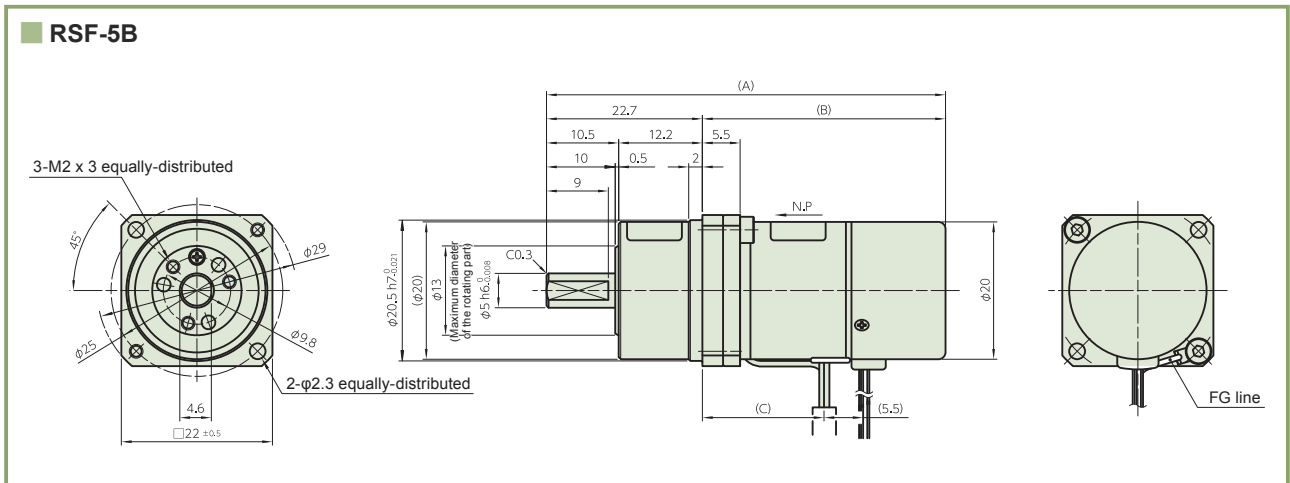
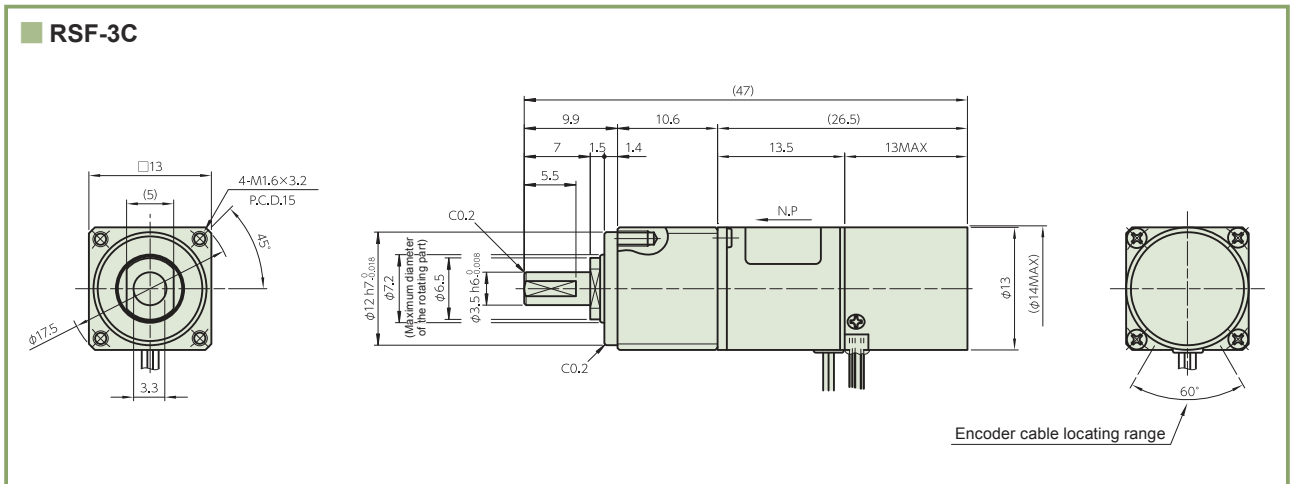
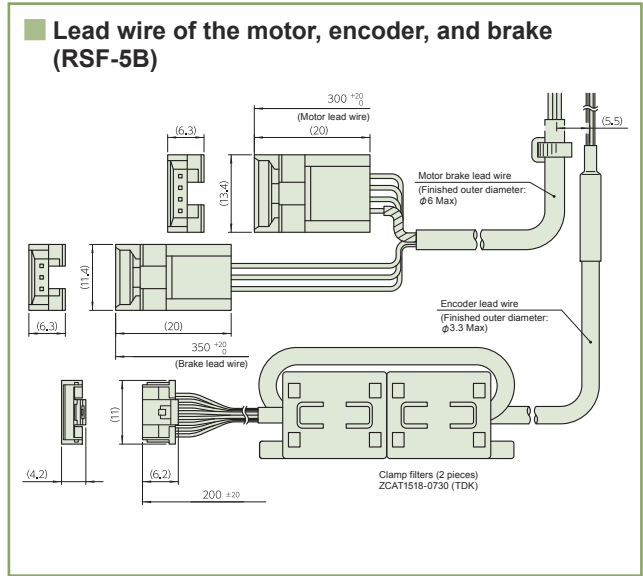
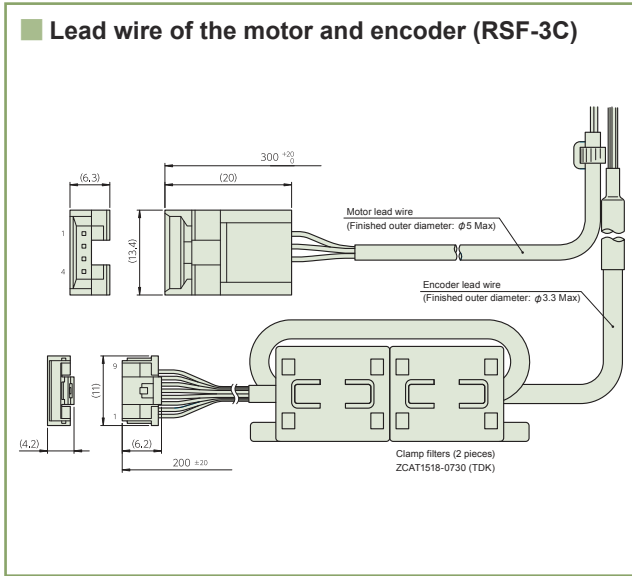

* A brake lead wire is not provided for RSF-5B (without a brake).

Dimension table

	A	B	C
RSF-5B (without a brake)	58.1	35.4	18
RSF-5B (with a brake)	69.1	46.4	29



■ Please contact our sales department with any questions.

Head Office

Ichigo Omori Building 7F, 6-25-3 Minami-Oi,
Shinagawa-ku, Tokyo 140-0013 JAPAN
Phone: +81-3-5471-7800 / FAX: +81-3-5471-7811

Overseas Division

1856-1 Hotakamaki, Azumino-shi, Nagano
399-8305 JAPAN
Phone: +81-263-83-6935 / FAX: +81-263-83-6901

Tokyo Office

Ichigo Omori Building 4F, 6-25-3 Minami-Oi,
Shinagawa-ku, Tokyo 140-0013 JAPAN
Phone: +81-3-5471-7830 / FAX: +81-3-5471-7836

Tokyo Office, Kitakanto Team

Ichigo Omori Building 4F, 6-25-3 Minami-Oi,
Shinagawa-ku, Tokyo 140-0013 JAPAN
Phone: +81-3-6410-8485 / FAX: +81-3-6410-8486

Koshin Office

1856-1 Hotakamaki, Azumino-shi, Nagano
399-8305 JAPAN
Phone: +81-263-83-6910 / FAX: +81-263-83-6911

Chubu Office

TM21-2F, 21 Terugaoka, Meito-ku, Nagoya-shi,
Yodogawa-ku, Osaka-shi, Osaka 532-0011 JAPAN
Phone: +81-52-773-7451 / FAX: +81-52-773-7462

Kansai Office

Shin-Osaka Ueno Toyo Building 3F, 7-4-17 Nishi-nakajima,
Yodogawa-ku, Osaka-shi, Osaka 532-0011 JAPAN
Phone: +81-6-6885-5720 / FAX: +81-6-6885-5725

Kyushu Office

NMF Hakata-ekimae Building 7F, 1-15-20 Hakata-ekimae,
Hakata-ku, Fukuokashi, Fukuoka 812-0011 JAPAN
Phone: +81-92-451-7208 / FAX: +81-92-481-2493

Hotaka Plant

1856-1 Hotakamaki, Azumino-shi, Nagano
399-8305 JAPAN
Phone: +81-263-83-6800 / FAX: +81-263-83-6901

Harmonic Drive AG

Hoenbergstrasse 14 D-65555 Limburg a.d. Lahn
GERMANY
Phone: +49-6431-5008-0 / FAX: +49-6431-5008-119

Harmonic Drive L.L.C.

247 Lynnfield Street, Peabody, MA 01960
U.S.A.
Phone: +1-978-532-1800 / FAX: +1-978-532-9406

Harmonic Drive Systems (Shanghai) Co., Ltd.

Rm206, 1#, No.641, Tianshan Rd, Changning District,
Shanghai, 200336, CHINA
Phone: +86-21-6237-5656 / FAX: +86-21-3250-7268

The data in this catalog is as of January 2019.

NO.1906-2R-C/F/R_mini_E

Environmentally-friendly vegetable-oil-based ink is used for this catalog.



Registered Trademark in Japan