

HarmonicDrive® Ultra-light Weight / Flat* Unit Type CSF-ULW Series

Size 8, 11

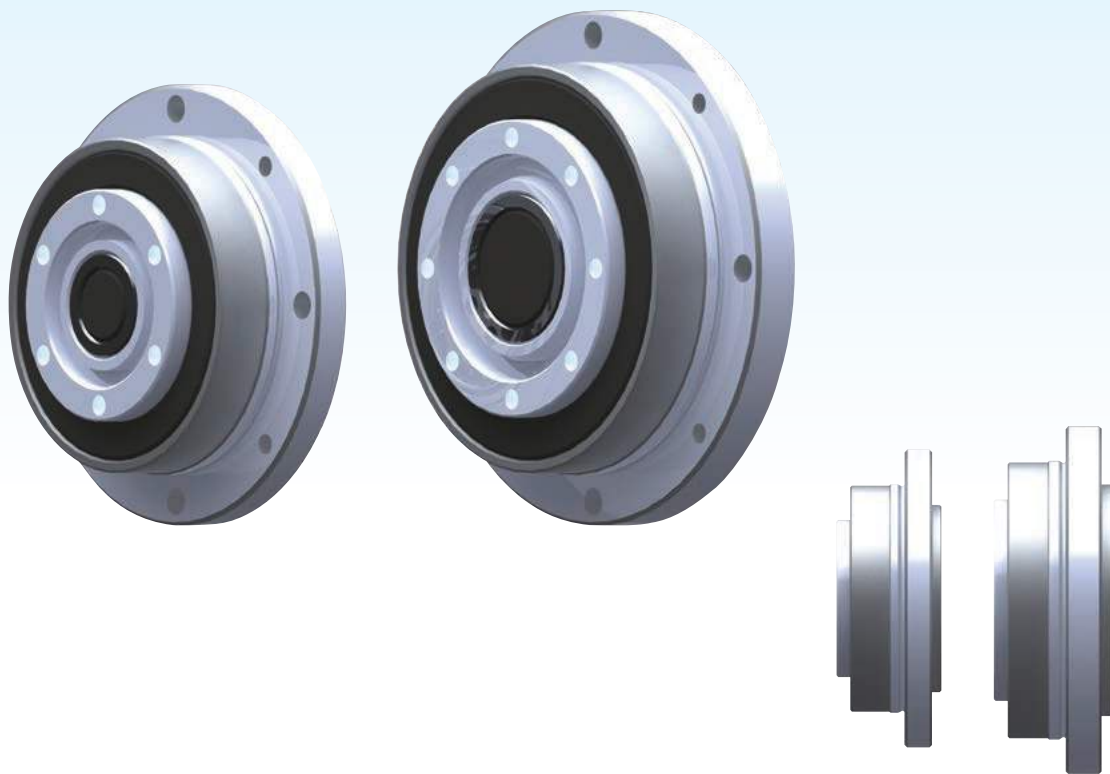

**We have just achieved the weight reduction and flat shape
of our products as never before.**

Our company has added a new series that pursues lightweight and flat shapes in HarmonicDrive® unit products.

We have also redesigned the structure and design of the CSF-2UH type, which is the main product of the unit products, and realized a lighter weight and flatter shape than ever before.

By adopting them in the tip axis of robots and various mechanical devices, our new series can be used to reduce the weight and size of robots and equipment as well as to improve performances. We will release size 8 and 11 of the CSF series in advance as a pioneer in developing the series.

* Our company's products have comparable Ultra-light weight/flatness. For more details, please refer to page 2 of this catalog.

Feature

- We have released size 8 and 11 of the CSF series in advance, prior to the development of the other series.
- We have also achieved the same performance as the other existing series (main bearing performance is excluded).

Comparison of Mass

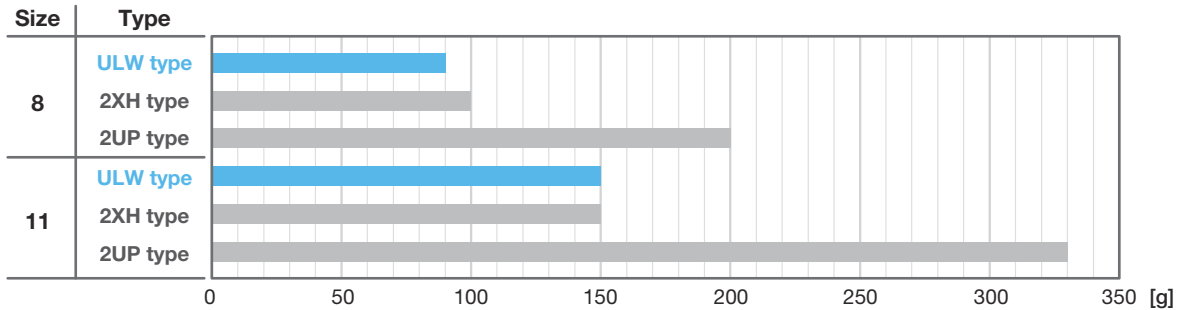

Comparison of full length

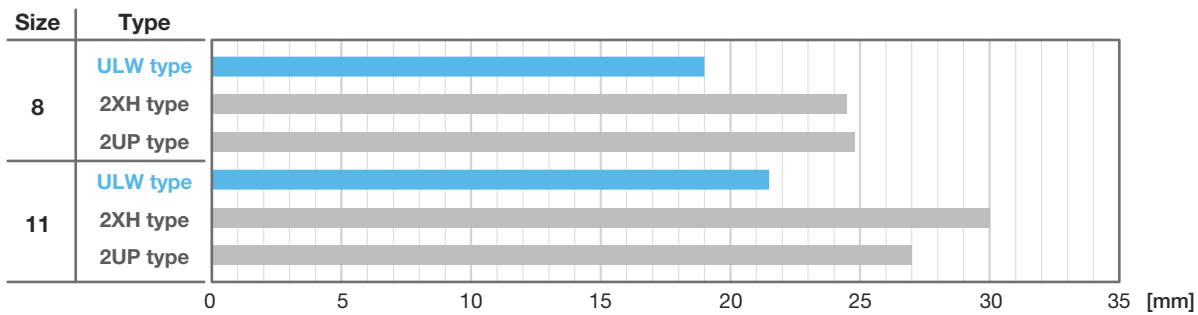

Comparison of allowable moment load

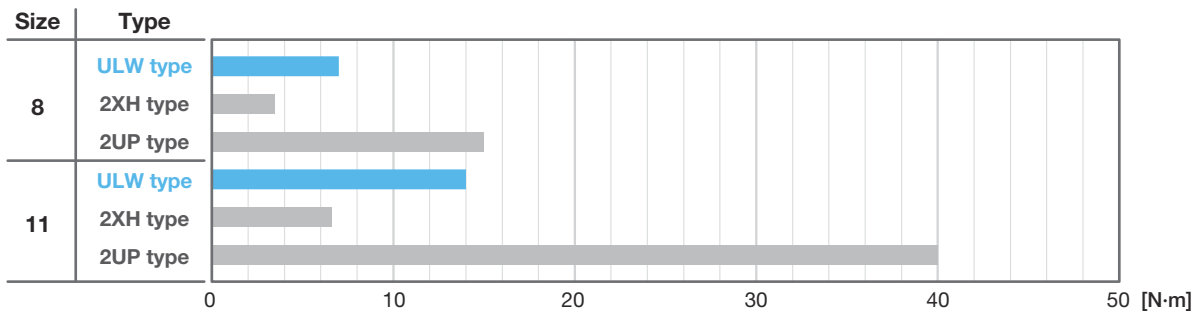

Ordering Code

CSF - 8 - 50 - 2UH - ULW - Specifications

Model	Size	Reduction ratio			Type	Specification 1	Special specifications
CSF series	8	30	50	100	2UH: Unit type	ULW: Ultra-light weight type	Blank = standard product SP = Special specifications such as the shape or performance
	11	30	50	100			

Rating Table

Size	Reduction ratio	Rated torque at input speed 2000 r/min		Limit for repeated peak torque		Limit for average torque		Limit for momentary peak torque		Allowable maximum input speed r/min	Allowable average input speed r/min	Moment of inertia (1/4GD ²) kg·m ²
		N·m	kgf·m	N·m	kgf·m	N·m	kgf·m	N·m	kgf·m			
8	30	0.9	0.09	1.8	0.18	1.4	0.14	3.3	0.34	8500	3500	1.7×10 ⁻⁷
	50	1.8	0.18	3.3	0.34	2.3	0.24	6.6	0.67			
	100	2.4	0.25	4.8	0.49	3.3	0.34	9.0	0.92			
11	30	2.2	0.22	4.5	0.46	3.4	0.35	8.5	0.87	8500	3500	8.6×10 ⁻⁷
	50	3.5	0.36	8.3	0.85	5.5	0.56	17	1.7			
	100	5.0	0.51	11	1.1	8.9	0.91	25	2.6			

Outline Drawing

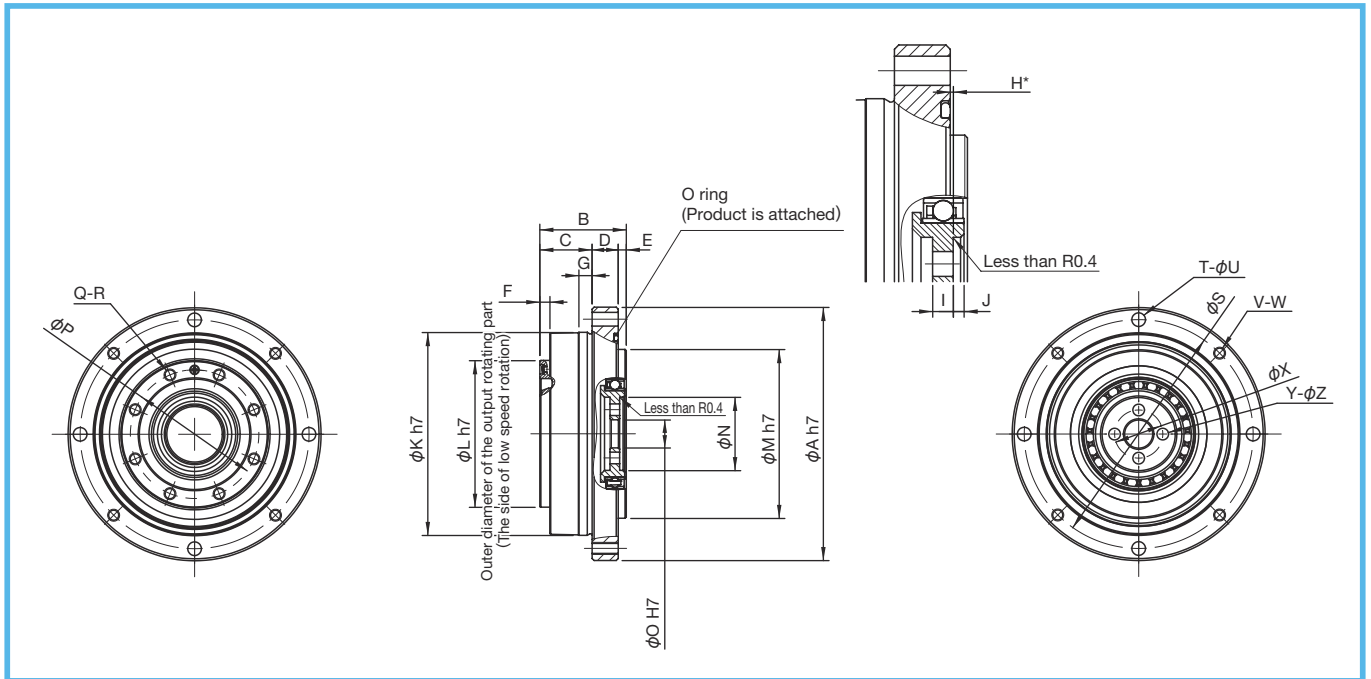

Dimension Table

[Unit: mm]

Size	Symbol	ϕA h7	B	C	D	E	F	G	H*	I	J	ϕK h7	ϕL h7	ϕM h7	ϕN
8		54	19.0	12.3	5.0	1.7	2.5	2.5	0.65 ⁰ _{-0.3}	2.0	0.65	41.5	28.5	34	12.5
11		63	21.5	13.0	6.5	2.0	2.5	3.3	0.35 ⁰ _{-0.7}	2.4	1.25	50.5	36.5	42	18.2

Size	Symbol	ϕO H7	ϕP	Q	R	ϕS	T	U	V	W	X	Y	Z	Weight (g)
8		3	24.5	6	M3	48	4	3.4	4	M3	7.5	4	2.4	90
11		7	32.0	8	M3	57	4	3.4	4	M3	12	4	2.9	150

* The H dimension is the axial fitting position and tolerance of the three parts (Wave Generator, Flexpline and Circular Spline) that make up the HarmonicDrive®. Please be sure to observe this dimension as it will affect its performance and strength.

Angular Transmission Error

Reduction ratio		Size	8	11
30	$\times 10^{-4}$ rad		5.8	5.8
	arc-min		2.0	2.0
50 or more	$\times 10^{-4}$ rad		5.8	4.4
	arc-min		2.0	1.5

Hysteresis Loss

Reduction ratio		Size	8	11
30	$\times 10^{-4}$ rad		8.7	8.7
	arc-min		3.0	3.0
50	$\times 10^{-4}$ rad		5.8	5.8
	arc-min		2.0	2.0
100	$\times 10^{-4}$ rad		5.8	5.8
	arc-min		2.0	2.0

Stiffness (spring constant)

Symbol		Size	8	11	
T1	N·m		0.29	0.80	
	kgf·m		0.030	0.082	
T2	N·m		0.75	2.00	
	kgf·m		0.077	0.200	
Reduction ratio 30	K1	$\times 10^4$ N·m/rad	0.034	0.084	
		kgf·m/arc-min	0.010	0.025	
	K2	$\times 10^4$ N·m/rad	0.044	0.130	
		kgf·m/arc-min	0.013	0.037	
	K3	$\times 10^4$ N·m/rad	0.054	0.160	
		kgf·m/arc-min	0.016	0.047	
	θ_1	$\times 10^{-4}$ rad	8.5	9.5	
		arc-min	3.0	3.3	
	θ_2	$\times 10^{-4}$ rad	19	19	
		arc-min	6.6	6.5	
	Reduction ratio 50	K1	$\times 10^4$ N·m/rad	0.044	0.220
			kgf·m/arc-min	0.013	0.066
K2		$\times 10^4$ N·m/rad	0.067	0.300	
		kgf·m/arc-min	0.020	0.090	
K3		$\times 10^4$ N·m/rad	0.084	0.320	
		kgf·m/arc-min	0.025	0.096	
θ_1		$\times 10^{-4}$ rad	6.6	3.6	
		arc-min	2.3	1.2	
θ_2		$\times 10^{-4}$ rad	13	8.0	
		arc-min	4.7	2.6	
Reduction ratio 100		K1	$\times 10^4$ N·m/rad	0.091	0.270
			kgf·m/arc-min	0.027	0.080
	K2	$\times 10^4$ N·m/rad	0.100	0.340	
		kgf·m/arc-min	0.031	0.100	
	K3	$\times 10^4$ N·m/rad	0.120	0.440	
		kgf·m/arc-min	0.036	0.130	
	θ_1	$\times 10^{-4}$ rad	3.2	3.0	
		arc-min	1.1	1.0	
	θ_2	$\times 10^{-4}$ rad	8.0	6.0	
		arc-min	2.6	2.2	

* This table shows the reference values. The lower limit value is approximately 80% of the displayed value.

* For details of terms, refer to the “Engineering Data” in the HarmonicDrive® General Catalog.

Starting Torque

(Unit: cN·m)

Reduction ratio \ Size	8	11
30	1.50	3.4
50	0.92	2.0
100	0.65	1.5

Overdrive Starting Torque

(Unit: N·m)

Reduction ratio \ Size	8	11
30	0.70	1.7
50	0.55	1.2
100	0.75	1.5

Positive Input Breaking Torque

If excessive torque is applied that exceeds the range of use, ratcheting, damage to the fastening part etc. and other damage that makes continuous use impossible will occur with a single load.

The minimum torque that causes such damage is defined as the positive input breaking torque.

(Unit: N·m)

Reduction ratio \ Size	8	11
30	15	40
50	16	47
100	19	60

Buckling Torque

(Unit: N·m)

Reduction ratio \ Size	8	11
Total reduction ratio	35	90

No-load Running Torque

No-load running torque is the input torque (high-speed shaft side) required to rotate a HarmonicDrive® under a no-load condition.

* For detailed value, contact our sales department.

Measuring condition

Lubrication condition	Speed reducer	Main bearing
	HarmonicGrease® SK-2	Multemp HL-D*

The torque value is measured after two or more hours run-in at 2000 r/min input speed.

* "Multemp" is a registered trademark of Kyodo Yushi Co., Ltd.

Compensation amount of no-load running torque

Reduction ratio	Size	8	11
30		0.54	1.05
50		0.23	0.43

Reduction ratio 100 of No-load Running Torque

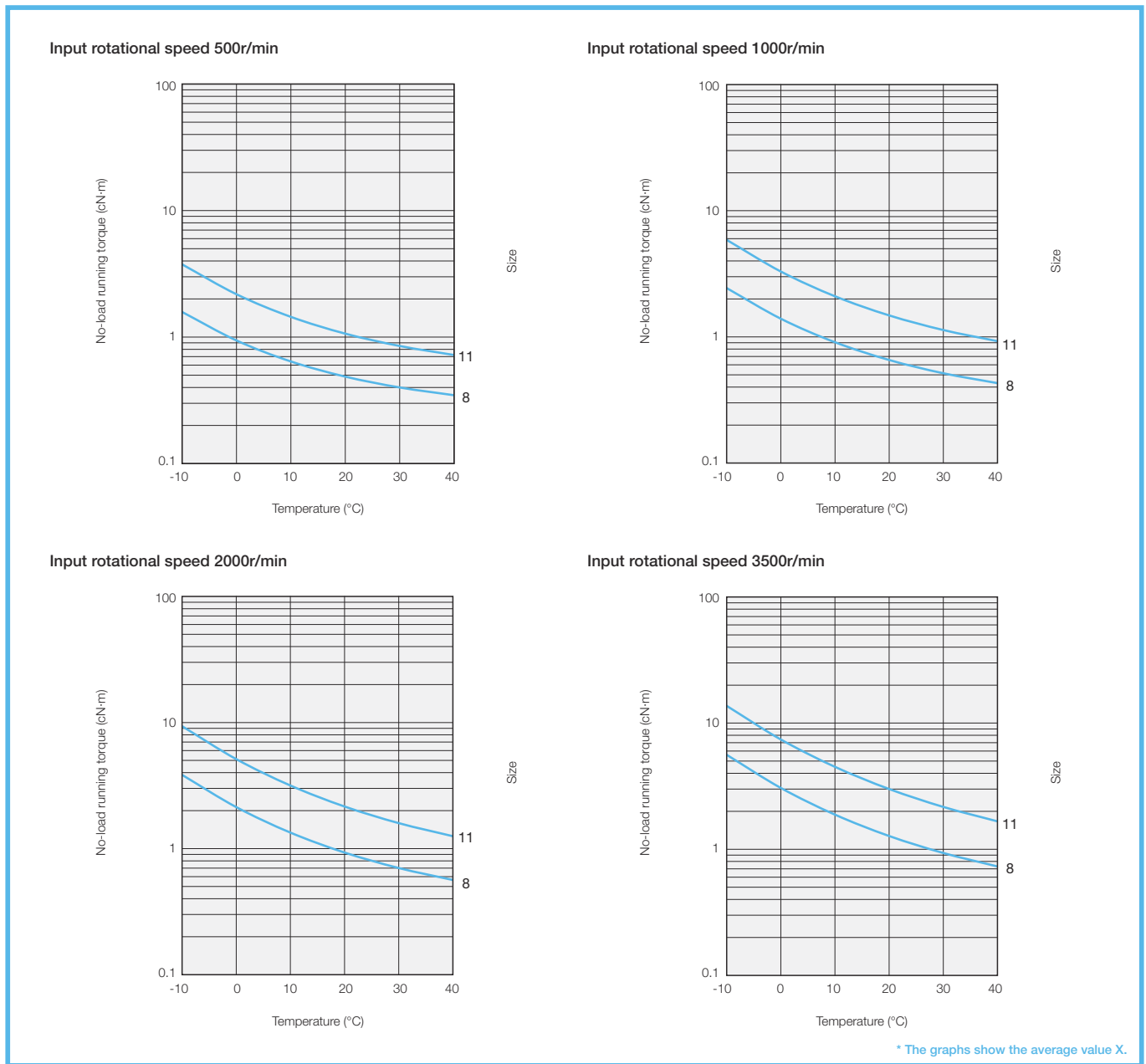

Efficiency Characteristics

The efficiency is varied depending on the load torque. Obtain efficiency compensation coefficient K_e from the graph, and check the value through the following formula.

*1 The efficiency compensation coefficient is the average value when the grease temperature is approximately 30°C.

*2 When load torque is larger than rated torque, efficiency compensation coefficient $K_e = 1$.

Efficiency compensation coefficient: K_e

Efficiency at rated torque: η_R

Efficiency depending on the load torque: η

$$\eta = K_e \times \eta_R$$

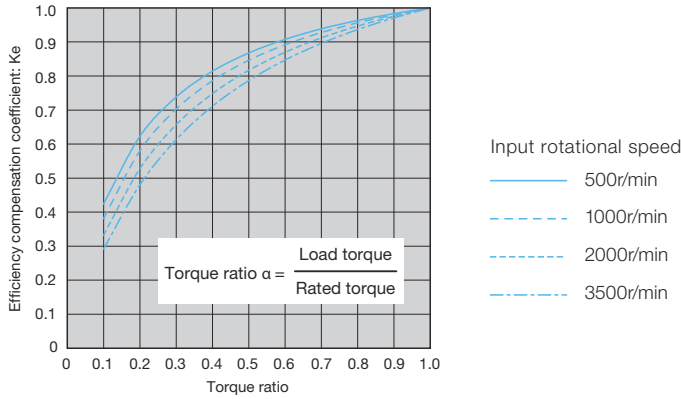

Measuring condition

Lubrication condition	Speed reducer	Main bearing
	HarmonicGrease® SK-2	Multemp HL-D*

The torque value is measured after two or more hours run-in at 2000 r/min input speed.

* "Multemp" is a registered trademark of Kyodo Yushi Co., Ltd.

Efficiency at rated torque

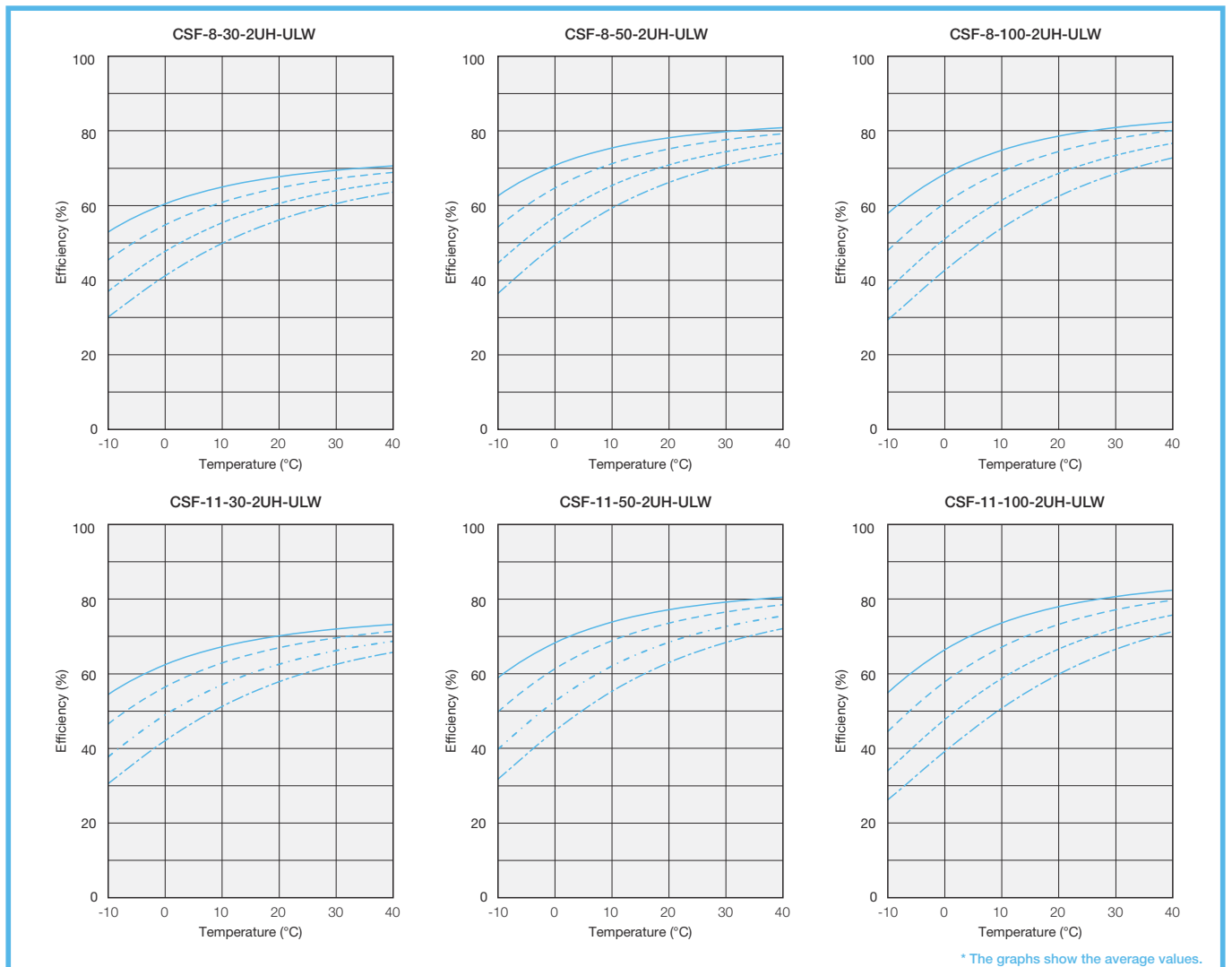

* The graphs show the average values.

Specifications of the Main Bearing

The CSF-ULW series incorporates a small 4-point contact ball bearing to directly support the external load (output part). Please check the maximum moment load, the life of the small 4-point contact ball bearing and the static safety coefficient to fully exert the performance of the CSF-ULW series.

Checking Procedure

For details of the checking procedure, refer to the “Checking Main Roller Bearing” in the “Engineering Data” in the HarmonicDrive® General Catalog.

(1) Checking the maximum moment load (M max)

Obtaining the maximum moment load (M max) → Maximum moment load (M max) ≤ Allowable moment (Mc)

(2) Checking the life

Obtaining the average radial load (F_{rav}) and average axial load (F_{aav}) → Obtaining the radial load coefficient (X) and axial load coefficient (Y)

→ Calculating the life and checking it

(3) Checking the static safety coefficient

Obtaining the static equivalent radial load (P₀) → Checking the static safety coefficient (f_s)

Main bearing specifications

Size	Pitch Circle	Offset	Basic rated load		Allowable moment load Mc	Moment stiffness Km
	dp	R	Basic dynamic load rating C	Basic static load rating C0		
	mm	mm	N	N		
8	29.0	7.90	1.8×10 ³	2.2×10 ³	7.9	10.0×10 ³
11	37.1	8.15	2.8×10 ³	3.5×10 ³	17	17.5×10 ³

* The basic dynamic load rating is a constant static radial load that provides a basic dynamic rating life of bearings to reach 1 million rotations.

* The basic static load rating is the static load that gives a certain level of contact stress (4.2kN/mm²) at the center of the contact area between the rolling element and raceway, which receives the maximum load.

* The allowable moment load is the maximum moment load that can be applied to the output shaft. Within this range, the basic performance is maintained, and the operation is possible for this value.

* The value of moment rigidity is a reference value, and the lower limit is approximately 80% of the displayed value. The lower limit value is approximately 80% of the displayed value.

Mechanical Accuracy

Symbol	Item precision	Size	
		8	11
a	Output shaft runout	0.010	0.010
b	Mounting pilot concentricity	0.050	0.050
c	Output flange surface runout	0.010	0.010
d	Parallelism between the mounting surface and the output flange surface	0.025	0.025

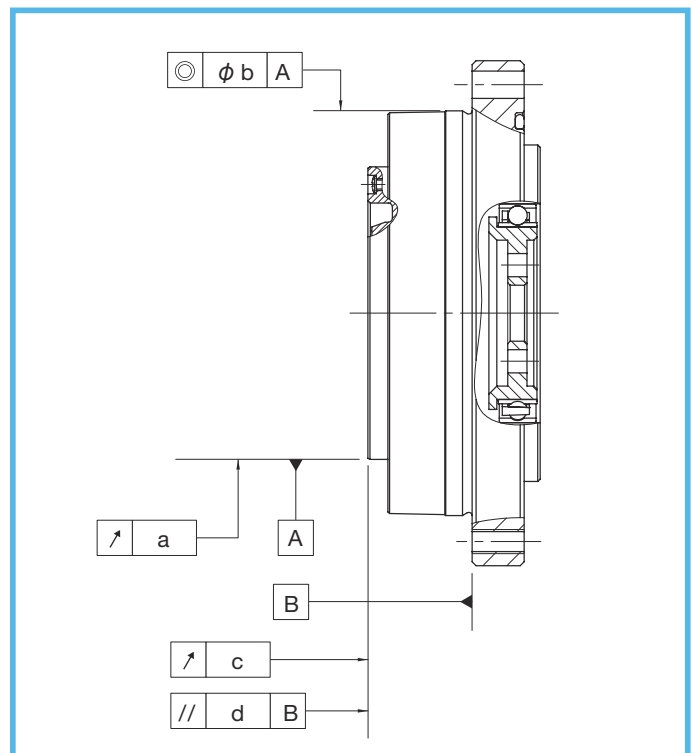

Assembling Accuracy

When installing, please retain the recommended accuracy shown below to make full use of the excellent performance of the CSF-2UH-ULW series.

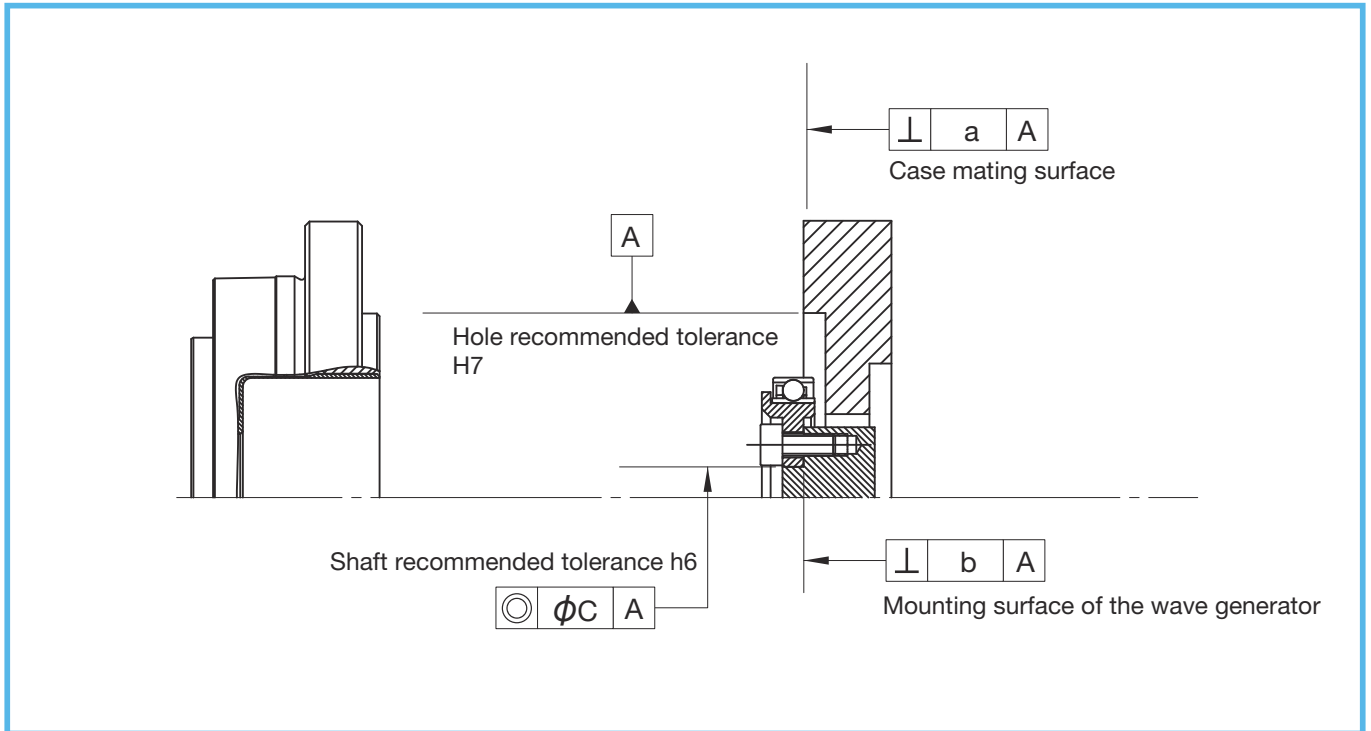

Symbol	Item precision	Size	
		8	11
a	Squareness of case mating surface	0.010	0.011
b	Squareness of the Wave Generator mounting surface	0.006	0.007
c	Concentricity of the input shaft	0.006	0.007

Installation and Transmission Torque

Precautions when installing the product

Regarding the installation design, if the product is installed abnormally or forcibly and the installation surface is damaged, the performance may be reduced. Prevent the failures described below to fully exert the performance of the unit type.

- Distortion or deformation of the installation surface
- Inclusion of foreign matter
- Burrs or elevation of the area around the tapped holes of the installation hole and error in the position accuracy
- Insufficiently chamfered installation pilot
- Error in the roundness of the installation pilot

Installation to the device

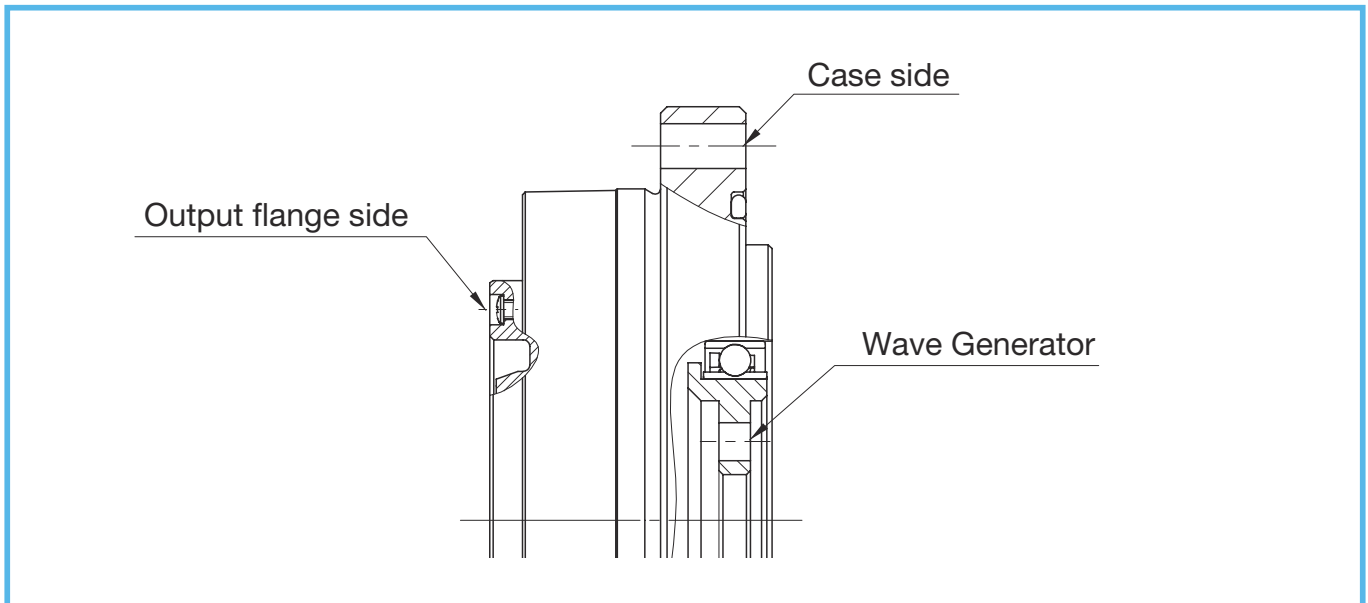

Installation and transmission torque on the side of output flange

Item		Size	8	11
Number of bolts			6	8
Bolt size			M3	M3
Mounting P.C.D	mm		24.5	32.0
Bolt tightening torque	N·m		2.0	2.0
	kgf·m		0.20	0.20
Bolt transmission torque	N·m		30.6	53.3
	kgf·m		3.12	5.43

Installation and transmission torque on the side of case

Item		Size	8	11
Number of bolts			4	4
Bolt size			M3	M3
Mounting P.C.D	mm		48	57
Bolt tightening torque	N·m		1.4	1.4
	kgf·m		0.14	0.14
Bolt transmission torque	N·m		28.0	33.2
	kgf·m		2.85	3.38

Installation and transmission torque on the side of Wave Generator

Item		Size	8	11
Number of bolts			4	4
Bolt size			M2	M2.5
Mounting P.C.D	mm		7.5	12
Bolt tightening torque	N·m		0.54	1.08
	kgf·m		0.055	0.110
Bolt transmission torque	N·m		2.53	6.48
	kgf·m		0.25	0.66

Precautions for Use

Use only in a specified environment

Ensure the following environmental conditions are complied with:

- Ambient temperature 0 to 40°C
- No splashing of water or oil
- Do not expose to corrosive or explosive gas
- No dust such as metal powder

* For other precautions, refer to the "HarmonicDrive® General Catalog."



■ Please contact our sales department with any questions.

Head Office

Ichigo Omori Building, 6-25-3 Minami-Oi,
Shinagawa-ku, Tokyo 140-0013 JAPAN
Phone: +81-3-5471-7800 / FAX: +81-3-5471-7811

Tokyo Office

Ichigo Omori Building, 6-25-3 Minami-Oi,
Shinagawa-ku, Tokyo 140-0013 JAPAN
Phone: +81-3-5471-7830 / FAX: +81-3-5471-7836

Tokyo Office, Kitakanto Team

Ichigo Omori Building, 6-25-3 Minami-Oi,
Shinagawa-ku, Tokyo 140-0013 JAPAN
Phone: +81-3-6410-8485 / FAX: +81-3-6410-8486

Koshin Office

1856-1 Hotakamaki, Azumino-shi, Nagano
399-8305 JAPAN
Phone: +81-263-83-6910 / FAX: +81-263-83-6911

Chubu Office

TM21-2F, 21 Terugaoka, Meito-ku, Nagoya-shi,
Aichi 465-0042 JAPAN
Phone: +81-52-773-7451 / FAX: +81-52-773-7462

Kansai Office

Shin-Osaka Ueno Toyo Building 3F, 7-4-17 Nishi-nakajima,
Yodogawa-ku, Osaka-shi, Osaka 532-0011 JAPAN
Phone: +81-6-6885-5720 / FAX: +81-6-6885-5725

Kyushu Office

NMF Hakata-ekimae Building 7F, 1-15-20 Hakata-ekimae,
Hakata-ku, Fukuokashi, Fukuoka 812-0011 JAPAN
Phone: +81-92-451-7208 / FAX: +81-92-481-2493

Overseas Division

1856-1 Hotakamaki, Azumino-shi, Nagano
399-8305 JAPAN
Phone: +81-263-83-6935 / FAX: +81-263-83-6901

Hataka Plant

1856-1 Hotakamaki, Azumino-shi, Nagano
399-8305 JAPAN
Phone: +81-263-83-6935 / FAX: +81-263-83-6901

"HarmonicDrive" is a trademark of Harmonic Drive Systems Inc.

The academic or generic term of our "HarmonicDrive" products is "strain wave gearing".

