

HarmonicDrive® Large-hollow-shaft Speed Reducer Unit FBS-2UH Series



Compact- and smaller-footprint-design realized

This HarmonicDrive® features large hollow shaft and smaller outer diameter as a new design.

Fully seeking the hollow shaft, one of the HarmonicDrive® features, we've developed the new-design unit with the fully-reduced outer diameter.

The newly-designed HarmonicDrive® FBS type has been adopted to realize the characteristic shape.

This series provides the robot edge shaft or mechanical devices that are facing the challenge of cable layout with more compact- and smaller-footprint-design.

Feature

- Ratio of the hollow-shaft diameter to the outer diameter has increased 20% compared with the previous products.
- The maximum hollow-shaft diameter and minimum outer diameter have been pursued for each size.
- 2 types of the size and the speed reduction ratio have been added to the product lineup.
- The newly designed HarmonicDrive® FBS type has been adopted.

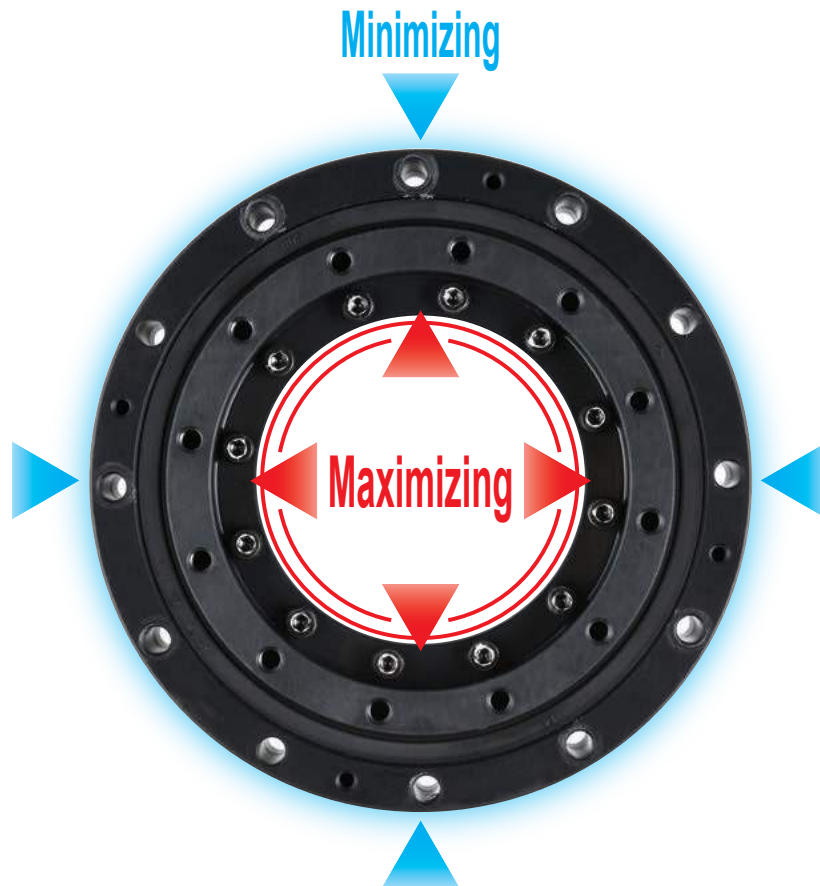

Ratio of the hollow-shaft diameter to the outer diameter

Size	Hollow-shaft diameter	Outer diameter	Ratio
25	41 mm	93 mm	44%
32	55.1 mm	113 mm	49%

Ordering Code

FBS - 25 - 30 - 2UH - specifications

Type	Size	Reduction ratio		Type	Special specifications
FBS series	25	30	50	Unit type	Blank = standard product SP = Special specifications such as the shape or performance
	32	30	50		

Rating Table

Size	Reduction ratio	Rated torque at input speed 2000 r/min		Limit for repeated peak torque		Limit for average torque		Limit for momentary peak torque		Allowable maximum input speed	Allowable average input speed	Moment of inertia (1/4GD ²)
		Nm	kgfm	Nm	kgfm	Nm	kgfm	Nm	kgfm	r/min	r/min	kgcm ²
25	30	15	1.5	25	2.5	24	2.4	50	5.1	3600	2500	1.0
	50	22	2.2	47	4.8	35	3.6	93	9.5			
32	30	30	3.1	48	4.9	48	4.9	96	9.8		2300	3.3
	50	43	4.4	92	9.4	67	6.8	151	15.4			

Outline drawing

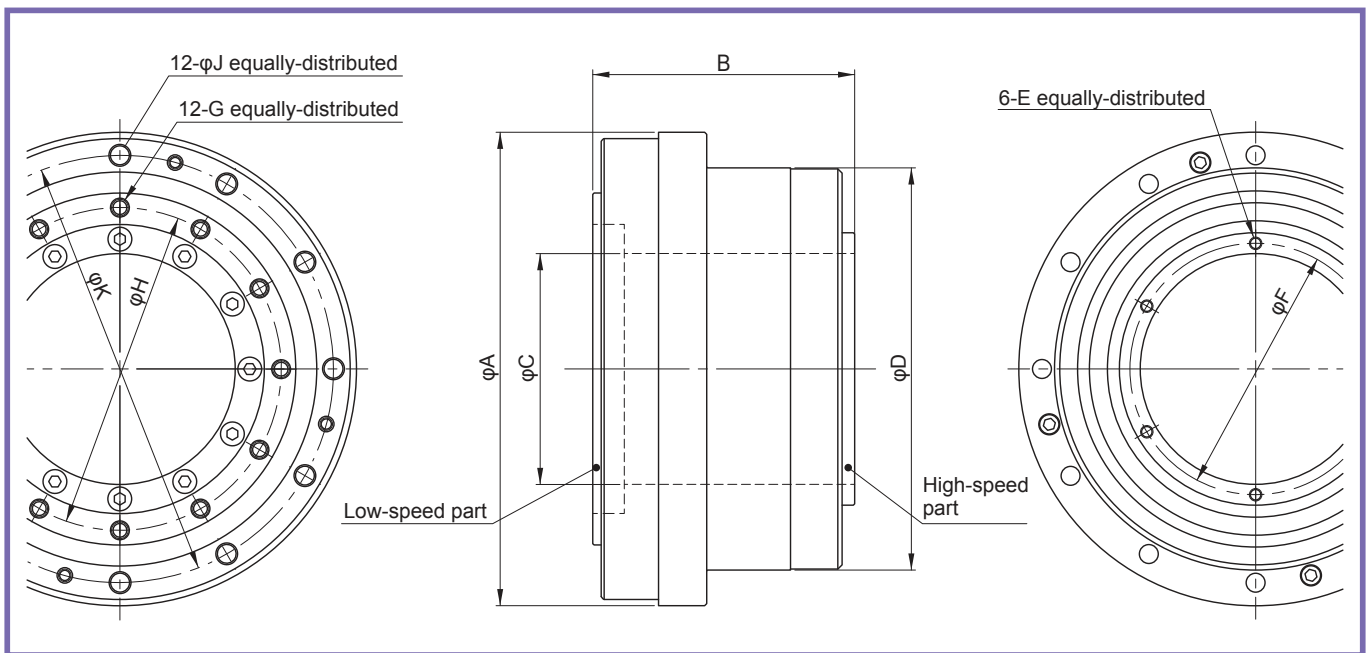

(Unit: mm)

Size	Symbol	φA	B	φC	φD	E	φF	G	φH	φJ	φK	Weight (kg)
25		93	53.1	41	78	M3	45.5	M3	61.4	3.5	84	1.3
32		113	62.5	55.1	96	M3	60	M4	77	4.5	102	2.2

Input part (wave generator axial clearance)

The support structure of the input part has internal clearance, and the input part moves depending on the external force or operating conditions. The following table shows the axial clearance.

If positioning in the axial direction is required, the design that can fix the part must be secured.

(Unit: mm)

Size	Dimension X	Axial clearance	
		a	b
25	3	0.1 to 0.7	0.0 to 0.6
32	3	0.2 to 0.8	0.1 to 0.7

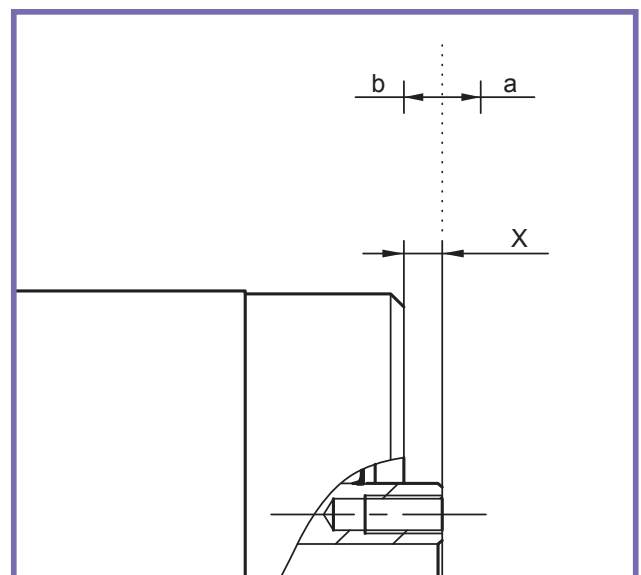

* For details of terms, refer to the technical material in the Harmonic Drive® general catalog.

Angle transmission accuracy

Reduction ratio		Size	25	32
30	x 10 ⁻⁴ rad		8.7	8.7
	arc min		3	3
50	x 10 ⁻⁴ rad		5.8	5.8
	arc min		2	2

Hysteresis loss

Reduction ratio		Size	25	32
30	x 10 ⁻⁴ rad		8.7	8.7
	arc min		3	3
50	x 10 ⁻⁴ rad		5.8	5.8
	arc min		2	2

Stiffness (spring constant)

Symbol		Size	25	32	
T1	Nm		7.4	16	
	kgfm		0.75	1.6	
T2	Nm		26	55	
	kgfm		2.7	5.6	
Reduction ratio 30	K1	x 10 ⁴ Nm/rad	1.3	2.1	
		kgfm/arc min	0.40	0.64	
	K2	x 10 ⁴ Nm/rad	1.3	2.4	
		kgfm/arc min	0.40	0.71	
	K3	x 10 ⁴ Nm/rad	1.6	2.9	
		kgfm/arc min	0.48	0.87	
	θ1	x 10 ⁻⁴ rad	5.4	7.4	
		arc min	1.9	2.5	
	θ2	x 10 ⁻⁴ rad	19	24	
		arc min	6.6	8.2	
	Reduction ratio 50	K1	x 10 ⁴ Nm/rad	1.9	3.5
			kgfm/arc min	0.56	1.0
K2		x 10 ⁴ Nm/rad	2.0	3.7	
		kgfm/arc min	0.60	1.1	
K3		x 10 ⁴ Nm/rad	2.3	4.3	
		kgfm/arc min	0.69	1.3	
θ1		x 10 ⁻⁴ rad	3.9	4.5	
		arc min	1.4	1.6	
θ2		x 10 ⁻⁴ rad	13	15	
		arc min	4.5	5.2	

* This table shows the reference values. The lower limit value is approximately 70% of the displayed value.

* For details of terms, refer to the technical material in the Harmonic Drive® general catalog.

Starting torque

(Unit: cNm)

Reduction ratio \ Size	25	32
30	25	54
50	15	31

Speed-up starting torque

(Unit: Nm)

Reduction ratio \ Size	25	32
30	11	23
50	9	18

Ratcheting torque

(Unit: Nm)

Reduction ratio \ Size	25	32
30	170	270
50	200	410

Acceleration breakdown torque

If the torque that exceeds the value listed in the following table is applied to the output part while the input part is fixed, the tightening part of the unit is damaged, and the torque cannot be transmitted.

(Unit: Nm)

Reduction ratio \ Size	25	32
30	370	730
50		

No-load running torque

No load running torque is the input torque (high-speed shaft side) that is required to rotate a HarmonicDrive® with no load applied to the output.

* For detailed value, please contact our sales department.

Measuring condition

Lubrication condition	Speed reducer	Main bearing
	Harmonic Grease® SK-1A	Harmonic grease® 4B No.2
The torque value is measured after two or more hours run-in at 2000 r/min input speed.		

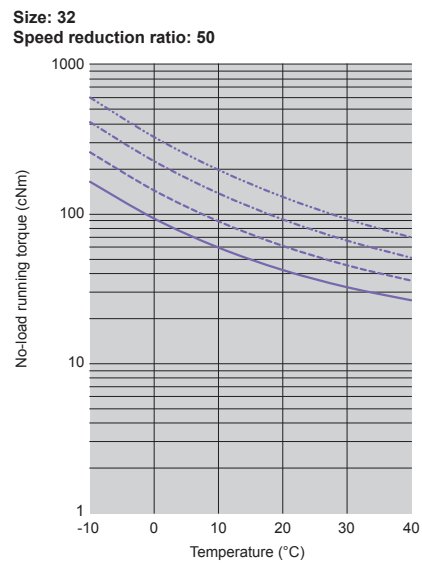
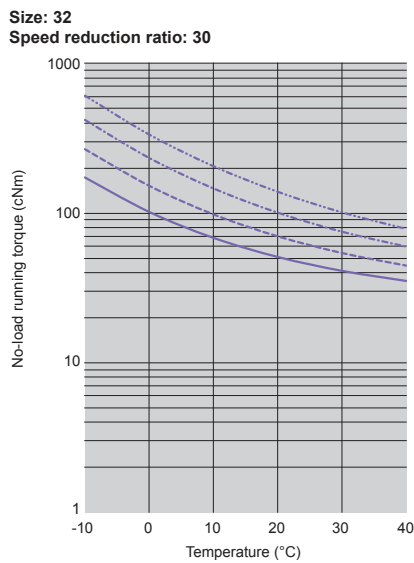
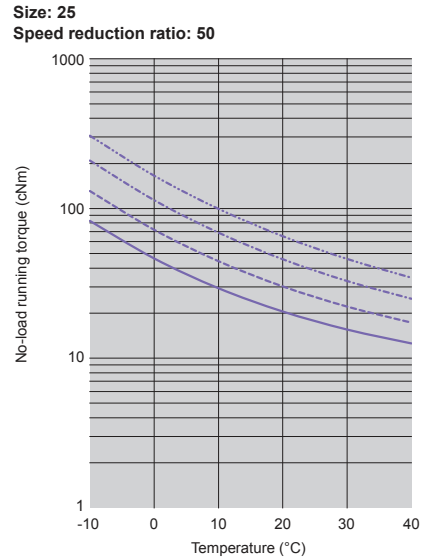
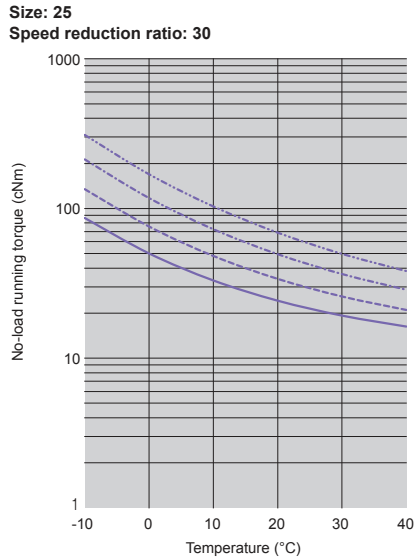

Input speed — 500r/min - - - - - 1000r/min - · - · - · 2000r/min · · · · · 3500r/min * The graphs show the average values.

Efficiency characteristics

The efficiency is lowered depending on the load torque. Obtain efficiency compensation coefficient K_e from the graph, and check the value through the following formula.

- *1 The efficiency compensation coefficient is the average value when the grease temperature is approximately 30°C.
- *2 When load torque is larger than rated torque, efficiency compensation coefficient $K_e = 1$.

Efficiency compensation coefficient: K_e
 Efficiency at rated torque: η_R
 Efficiency depending on the load torque: η
 $\eta = K_e \times \eta_R$

$$\text{Torque ratio } \alpha = \frac{\text{Load torque}}{\text{Rated torque}}$$

Efficiency compensation coefficient

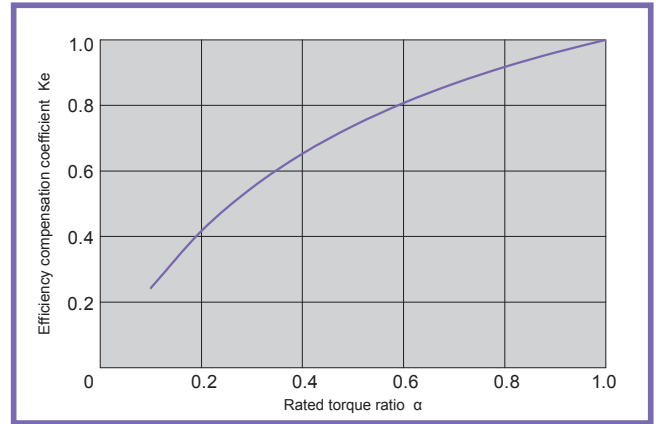

Measuring condition

Lubrication condition	Speed reducer	Main bearing
	Harmonic Grease® SK-1A	Harmonic grease® 4B No.2

The efficiency value is measured after two or more hours run-in at 2000 r/min input speed.

Efficiency at rated torque

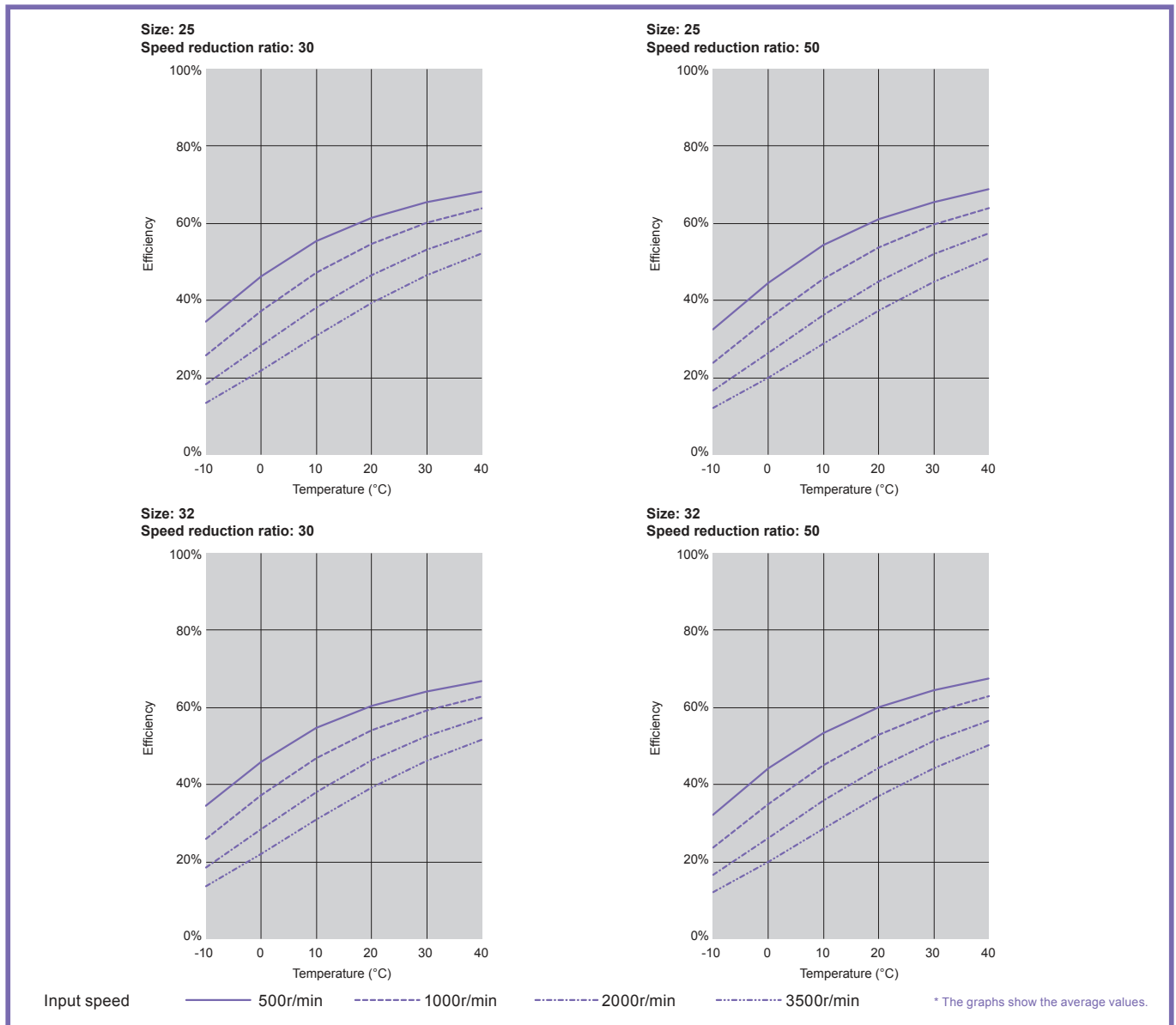

Specifications of the main bearing

The unit type incorporates the accuracy cross roller bearing (output flange) to directly support the external load. To fully exert the unit type performance, check the maximum moment load, life of the cross roller bearing, and static safety coefficient.

■ Procedure for checking

(1) Checking the maximum moment load (M max)

Obtaining the maximum moment load (M max) → Maximum moment load (M max) ≤ Allowable moment (Mc)

(2) Checking the life

Obtaining the average radial load (Frav) and average axial load (Faav) → Obtaining the radial load coefficient (X) and axial load coefficient (Y)

→ Calculating the life and checking it

(3) Checking the static safety coefficient

Obtaining the static equivalent radial load (Po) → Checking the static safety coefficient (fs)

Main bearing specifications

Size	Pitch Circle	Offset	Basic rated load				Permissible moment load Mc		Moment stiffness Km	
	dp	R	Basic dynamic load rating C		Basic static load rating C0		Nm	kgfm	x 10+ Nm/rad	kgfm/arc min
	m	m	×10 ² N	kgf	×10 ² N	kgf				
25	0.070	0.011	73	744	110	1122	93	9.5	21	6.2
32	0.086	0.0121	109	1111	179	1825	129	13.2	31	9.2

Mechanical accuracy

Symbol \ Size	25	32
a	0.015	0.015
b	0.010	0.010
c	0.010	0.010
d	0.010	0.013
e	0.070	0.073
f	0.010	0.010
g	0.018	0.024

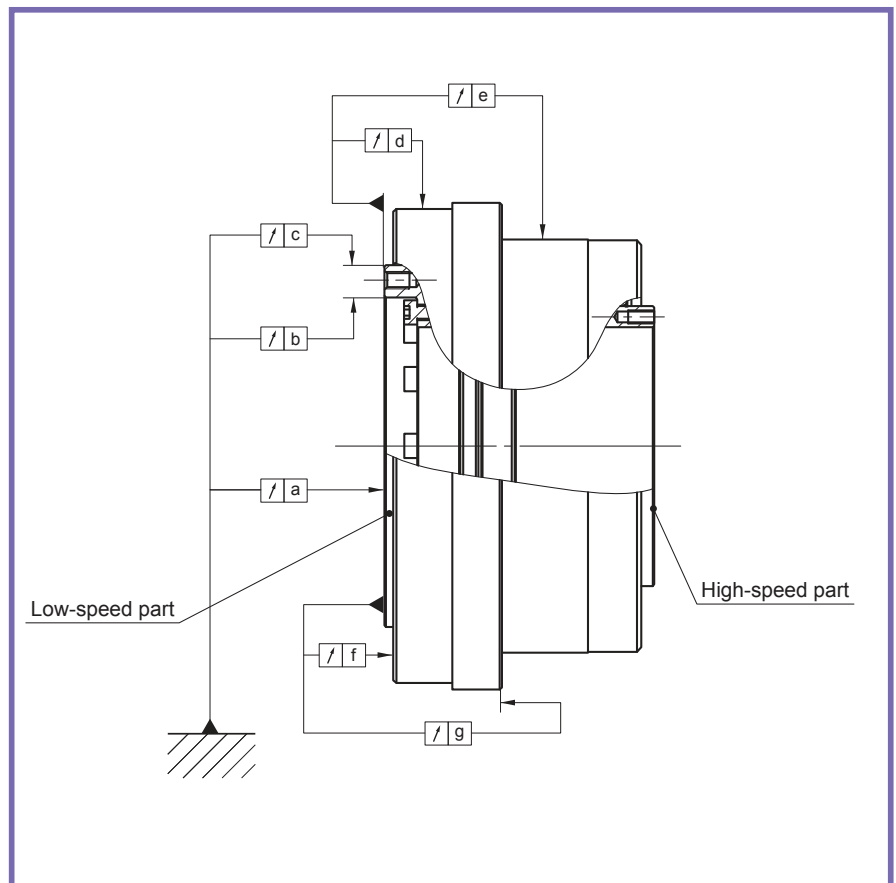

Allowable load for the input part

Two bearings support the input part. To fully exert the performance, please check the load to be applied to the input part. The following graph shows the maximum allowable radial load and thrust load for each size. Note that the values on the graph are the examples when the average input speed is 2000 r/min and basic rating life L_{10} is 5,000 hours.

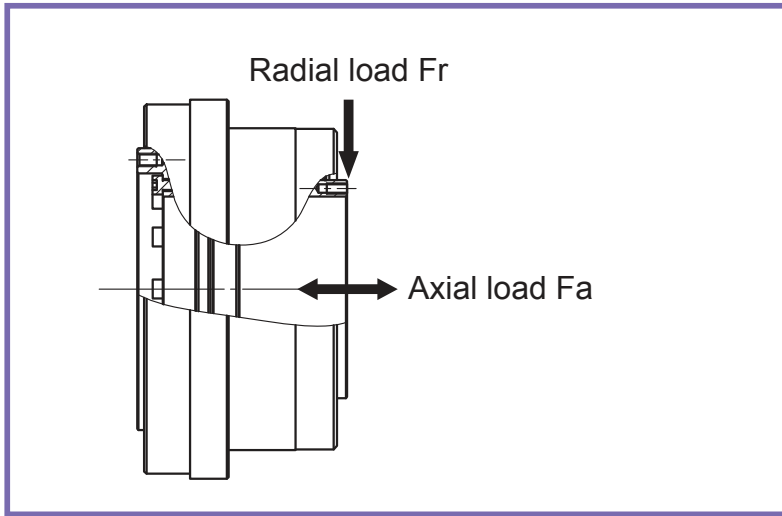

Thrust force of the input shaft

A thrust force applies to the wave generator during HarmonicDrive® operation due to elastic deformation of the flex spline. In response to this force, this product may move in the shaft direction since the wave generator support structure has the clearance.

To reduce the movement in the input shaft direction, the design to receive the thrust force must be secured.

The thrust force (maximum value) of the wave generator can be obtained through the following formula.

The severity and direction of the thrust force varies depending on the operating conditions. The thrust force tends to increase at the extremely low speed and during the fixed continuous speed while the torque is higher, and is approximately equal to the value obtained by the formula. In both cases, the design to receive the thrust force of the wave generator must be secured.

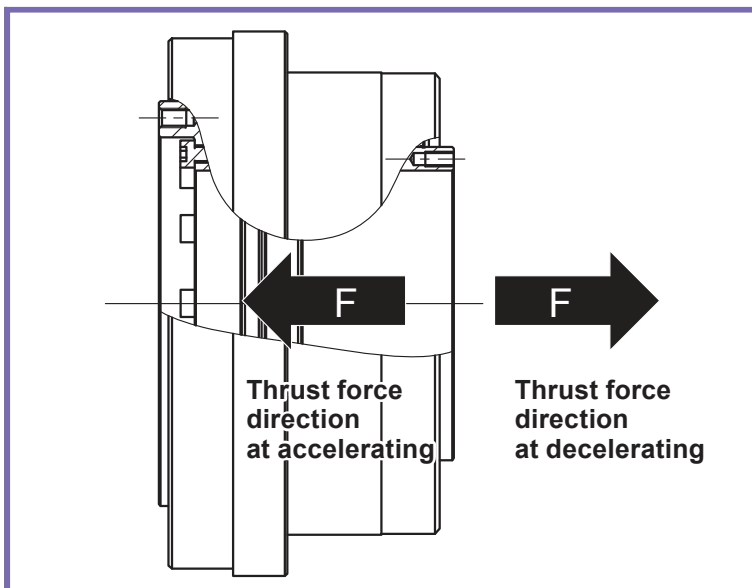

Reduction ratio	Formula
30	$F = 5.2 \times \frac{T}{D} \times 0.07 \times \tan 32^\circ$
50	$F = 5.2 \times \frac{T}{D} \times 0.07 \times \tan 30^\circ$

F = Thrust force (N)
T = Output torque (Nm)
D = (Size) x 0.00254 (m)

Installation and transmission torque

Precautions when installing the product

Regarding the installation design, if the product is installed abnormally or forcibly and the installation surface is damaged, the performance may be reduced. Prevent the failures described below to fully exert the performance of the unit type.

- Distortion or deformation of the installation surface
- Inclusion of foreign matter
- Burrs or elevation of the area around the tap of the installation hole and error in the position accuracy
- Insufficiently chamfered installation spigot joint
- Error in the roundness of the installation spigot joint

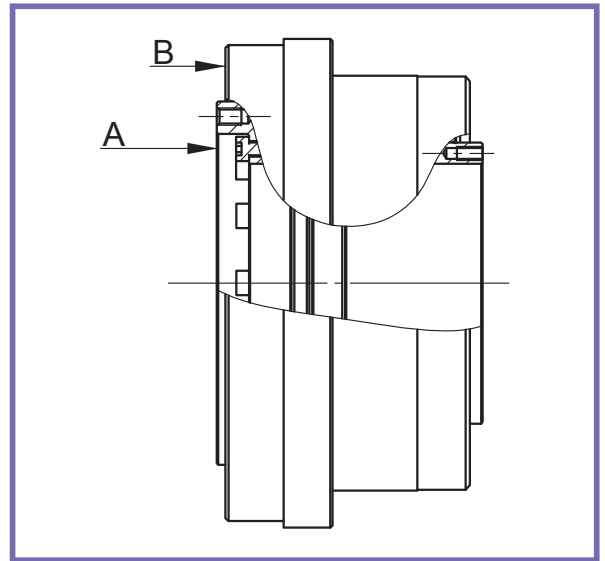

Installation and bolt transmission torque on the side of A

Item		Size	25	32
Number of bolts			12	12
Bolt size			M3	M4
Mounting P.C.D	mm		61.4	77
Bolt tightening torque	Nm		2.0	4.5
	kgfm		0.2	0.46
Bolt transmission torque	Nm		154	324
	kgfm		15.7	33.1

1. This value is based on the premise that the material of the female screw can endure the bolt tightening torque.
2. Recommended bolt: JIS B 1176 Hexagon socket head bolt (Strength section: JIS B 1051 12.9 or more)
3. Torque coefficient: K = 0.2
4. Tightening coefficient: A = 1.4
5. Friction coefficient μ of the joining surfaces = 0.15

Installation and bolt transmission torque on the side of B

Item		Size	25	32
Number of bolts			12	12
Bolt size			M3	M4
Mounting P.C.D	mm		84	102
Bolt tightening torque	Nm		2.0	4.5
	kgfm		0.2	0.46
Bolt transmission torque	Nm		210	431
	kgfm		21	44

1. This value is based on the premise that the material of the female screw can endure the bolt tightening torque.
2. Recommended bolt: JIS B 1176 Hexagon socket head bolt (Strength section: JIS B 1051 12.9 or more)
3. Torque coefficient: K = 0.2
4. Tightening coefficient: A = 1.4
5. Friction coefficient μ of the joining surfaces = 0.15

Recommended runout processing of the installation spigot joint

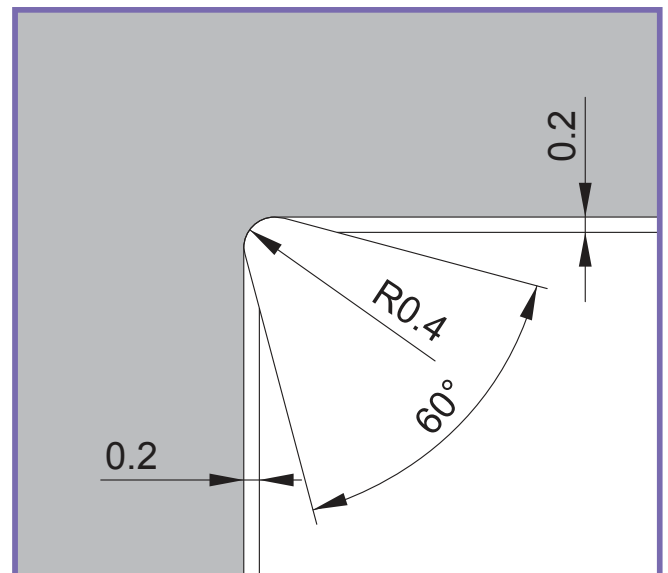
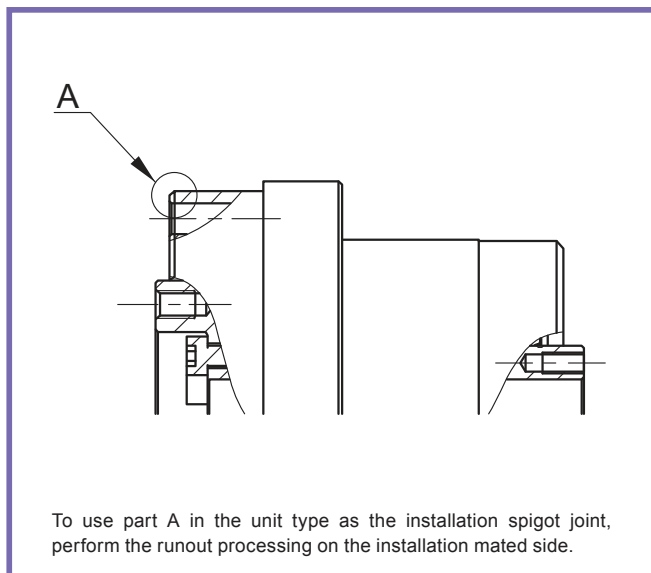

Lubrication

For lubrication of FBS-2UH, grease is used. The product is shipped while the grease is sealed, and adding or application of the grease is not required when installing the product.

The following grease is used as the lubrication agent.

Grease replacement intervals

* For details, refer to “Technical material”.

Lubrication part	Speed reducer	Main bearing
Lubrication agent to be used	Harmonic Grease® SK-1A	Harmonic Grease® 4B No.2
Manufacturers	Harmonic Drive Systems Inc.	
Base oil	Purified mineral oil	Synthetic hydrocarbon oil
Thickener	Lithium soap base	Urea
Mixing consistency (25°C)	265 to 295	290 to 320
Drop point	197°C	247°C
Appearance	Yellow	Light yellow

Application

FBS-2UH is not equipped with the sealing mechanism on the input side (high speed side) to prevent larger loss of friction caused by the larger-diameter sealing mechanism.

The following figure shows an example of sealing of the housing and on the output side (low speed side) to reduce loss of friction on the input side (high speed side) and greatly utilize the hollow-shaft shape. Note that the sealing agent or sealing mechanism such as an O-ring is required for each part to prevent grease leakage.

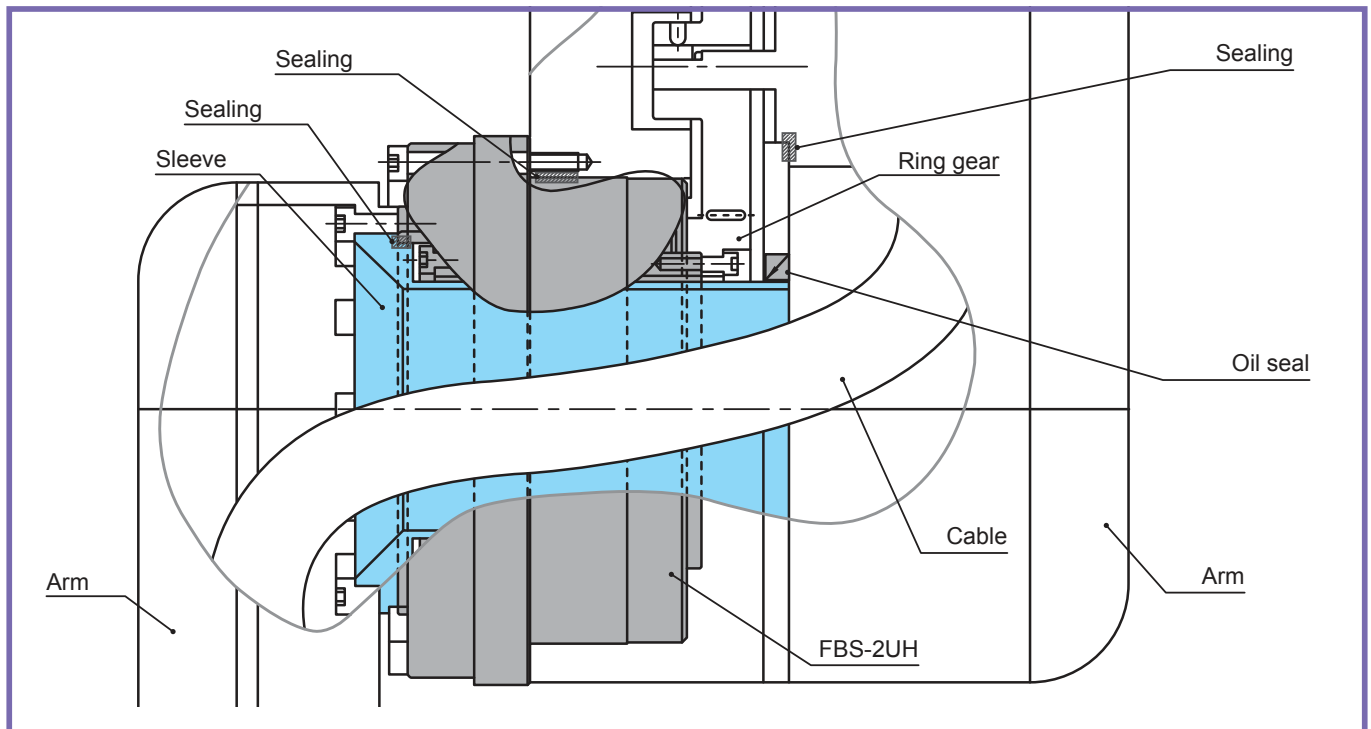



■ Please contact our sales department with any questions.

Head Office

Ichigo Omori Building 7F, 6-25-3 Minami-Oi,
Shinagawa-ku, Tokyo 140-0013 JAPAN
Phone: +81-3-5471-7830 / FAX: +81-3-5471-7811

Overseas Division

1856-1 Hotakamaki, Azumino-shi, Nagano
399-8305 JAPAN
Phone: +81-263-83-6935 / FAX: +81-263-83-6901

Tokyo Office

Ichigo Omori Building 4F, 6-25-3 Minami-Oi,
Shinagawa-ku, Tokyo 140-0013 JAPAN
Phone: +81-3-5471-7830 / FAX: +81-3-5471-7836

Tokyo Office, Kitakanto Team

Ichigo Omori Building 4F, 6-25-3 Minami-Oi,
Shinagawa-ku, Tokyo 140-0013 JAPAN
Phone: +81-3-6410-8485 / FAX: +81-3-6410-8486

Koshin Office

1856-1 Hotakamaki, Azumino-shi, Nagano
399-8305 JAPAN
Phone: +81-263-83-6910 / FAX: +81-263-83-6911

Chubu Office

TM21-2F, 21 Terugaoka Meito-ku, Nagoya-shi,
Aichi 465-0042 JAPAN
Phone: +81-52-773-7451 / FAX: +81-52-773-7462

Kansai Office

Shin-Osaka Ueno Toyo Building 3F, 7-4-17 Nishi-nakajima,
Yodogawa-ku, Osaka-shi, Osaka 532-0011 JAPAN
Phone: +81-6-6885-5720 / FAX: +81-6-6885-5725

Kyushu Office

NMF Hakata-ekimae Building 7F, 1-15-20 Hakata-ekimae,
Hakata-ku, Fukuokashi, Fukuoka 812-0011 JAPAN
Phone: +81-92-451-7208 / FAX: +81-92-481-2493

Hotaka Plant

1856-1 Hotakamaki, Azumino-shi, Nagano
399-8305 JAPAN
Phone: +81-263-83-6800 / FAX: +81-263-83-6901

Harmonic Drive AG

Hoenbergstrasse 14 D-65555 Limburg a.d. Lahn
GERMANY
Phone: +49-6431-5008-0 / FAX: +49-6431-5008-119

Harmonic Drive L.L.C.

247 Lynnfield Street, Peabody, MA 01960
U.S.A.
Phone: +1-978-532-1800 / FAX: +1-978-532-9406

Harmonic Drive Systems (Shanghai) Co., Ltd.

Rm206, 1#, No. 641, Tianshan Rd, Changning District,
Shanghai, 200336, CHINA
Phone: +86-21-6237-5656 / FAX: +86-21-3250-7268

<http://www.hds.co.jp>

"HarmonicDrive" is a trademark of Harmonic Drive Systems Inc.
The academic or generic term of our "HarmonicDrive" products is "strain wave gearing."