



EtherCAT®

Panasonic Corporation

MINAS
A6N/A6B/A6

HarmonicDrive®
Flat Hollow Shaft AC Servo Motor
PMA series

+

HarmonicDrive®



Panasonic Corporation

MINAS A6N compatible with RTEX (RealtimeExpress)

MINAS A6B compatible with EtherCAT

MINAS A6 compatible with Pulse/Analog/Modbus

Models Compatible with Collaboration have been added.

The flat hollow-shaft AC servo motor HMA series has become compatible with the latest servo amplifier MINAS A6 series manufactured by Panasonic Corporation and has become capable of controlling from various types of network.

Compatibility with RTEX, EtherCAT and general communication (serial, analog I/O, Modbus) integrates the user interface, and the hollow shaft mechanism contributes to reduction in size of the device configuration.

Contact: AC servo motor PMA series (Harmonic Drive Systems Inc.)

AC servo amplifier MINAS A6 (Panasonic Corporation)

Features

- The hollow shaft design provides the piping/wiring being layout on center of rotation without offsetting the motor. (The hollow shaft is selectable from $\phi 16$ to 60 mm.)
- The flat structure reduces the size of the device configuration.
- A wide variety of five sizes with the rated output from 163 to 1320W has been added to the lineup.
- Integrated brake option is available without dimension change.
- Provides easy connection to a system configured with RTEX, EtherCAT and general communication.

Hollow shaft design

Brake (option)

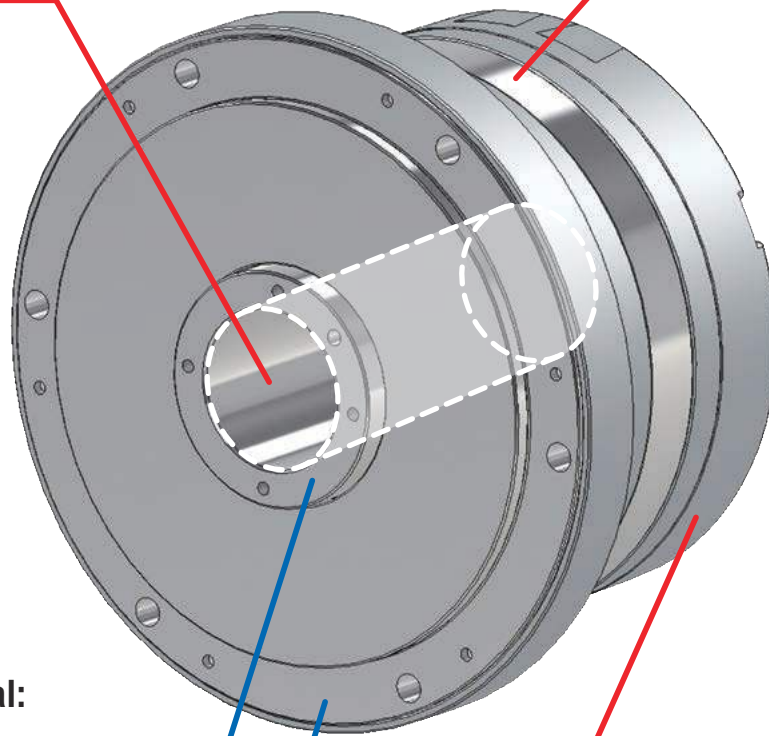

Motor shaft material:
Stainless Steel

Motor flange material:
Aluminum

Absolute encoder

Compatible with
Panasonic's format

Simple system configuration

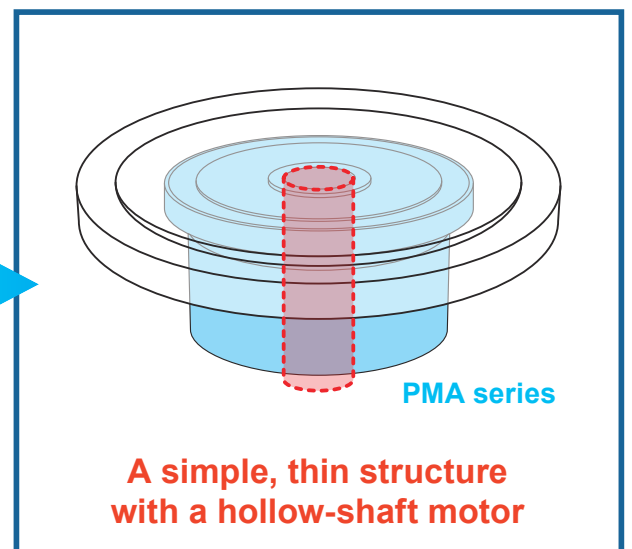
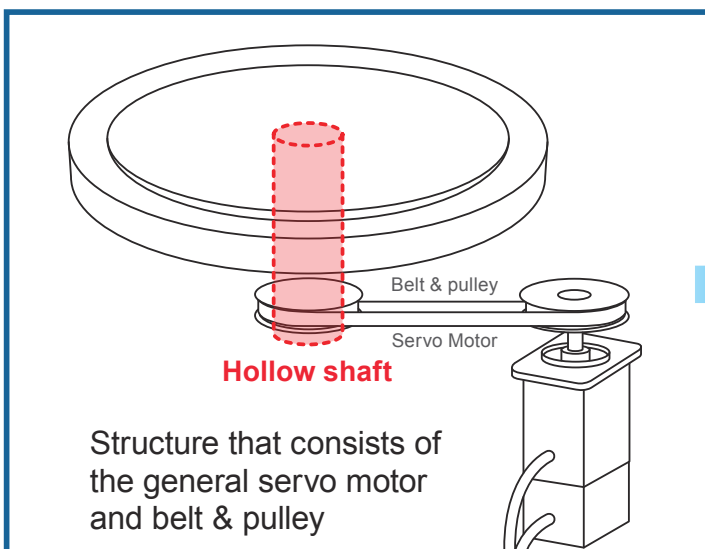

Panasonic AC Servo Amplifier MINAS A6

The MINAS A6 series is the latest servo amplifier manufactured by Panasonic Corporation, and is compatible with the various types of open network including Realtime Express uniquely developed by Panasonic Corporation.

- High-speed synchronization communication network (100 Mbps)
A6N series: RealtimeExpress (RTEX)
A6B series: EtherCAT
- General communication network (230 kbps)
A6 series: Pulse/Analog/Modbus



Combination of a servo amplifier with a relay cable

Motor model	Servo amplifier model			Relay cable	
	A6N series compatible with RTEX	A6B series compatible with EtherCAT	A6 series compatible with I/O communication	Motor cable	Encoder cable
PMAC08	MBDL■25N□	MBDL■25B□	MBDL■25S□	EWD-MB**-A06-TN-P	MFECA0**0EAE (Equipped with the battery box)
PMAB09	MCDL■35N□	MCDL■35B□	MCDL■35S□		
PMAB12	MDDL■55N□	MDDL■55B□	MDDL■55S□		
PMAB15	MEDL■83N□	MEDL■83B□	MEDL■83S□		
PMAA21A	MFDL■B3N□	MFDL■B3B□	MFDL■B3S□	EWD-MB**-D09-TMC-P	MFECA0**0ETE (Equipped with the battery box)

* "■" in the servo amplifier model is replaced with the symbol that indicates whether to enable the safety function.
T: Compatible with the safety function (Not available in the A6 SE, SG series)
N: Without the safety function

* "□" in the servo amplifier model is replaced with the symbol that indicates the compatible communication.
E: Position-control type (combination with the type not equipped with the safety function)
F: Multi-function type (combination with the type equipped with the safety function)
G: Modbus communication type (only for the A6 series) (combination with the type not equipped with the safety function)

* "**" in the relay cable type means the cable length. Refer to the following description.
03 = 3 m, 05 = 5 m, 10 = 10 m, 20 = 20 m

Controller compatible with RTEX and EtherCAT general communication

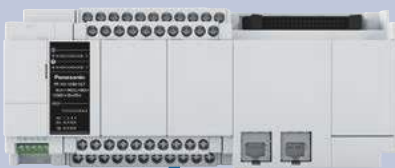

AC servo amplifier MINAS A6 series

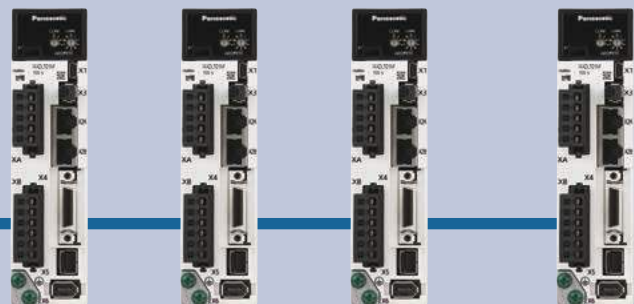

Servo motor manufactured by Panasonic



HarmonicDrive®

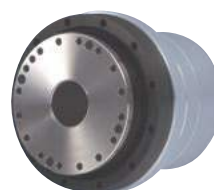

SHA-P series

NEW



PMA series

Ordering Code

PMA **B** **09** **A** **200** - **14** **S17b** **B** - **C** **Y** - **A6** - **SP**
 (1) (2) (3) (4) (5) (6) (7) (8) (9)(10) (11) (12)

(1)	Model name	AC servo motor PMA series
(2)	Motor version symbol	A: Size 21A B: Size 09, 12, 15 C: Size 08
(3)	Size	08, 09, 12, 15, 21A
(4)	Brake	A: Without brake B: With brake
(5)	Applied servo amplifier Input voltage	200 VAC
(6)	Encoder format	Compatible with Panasonic's format

(7)	Encoder Type and resolution	17-bit multi-revolution absolute encoder 131072 pulse/revolution
(8)	Encoder phase angle	Phase difference between the motor U phase and the encoder origin B: 30 degrees
(9)	Connector specification	C: With standard connectors N: Without connectors
(10)	Option symbols	No symbol: Standard product Y: Side exiting cable (Size 08 and 21A are not compatible.)
(11)	Amplifier combination symbol	A6: A6 series
(12)	Special specifications	No symbol: Standard product SP: Special-specification product

Option:

■ Side exiting cable (Symbol for option: Y)

Cables (motor cable and encoder cable) are exited from the side of the motor.

Use this option when there is not enough space in the rear direction of housing when installing a motor in the device.

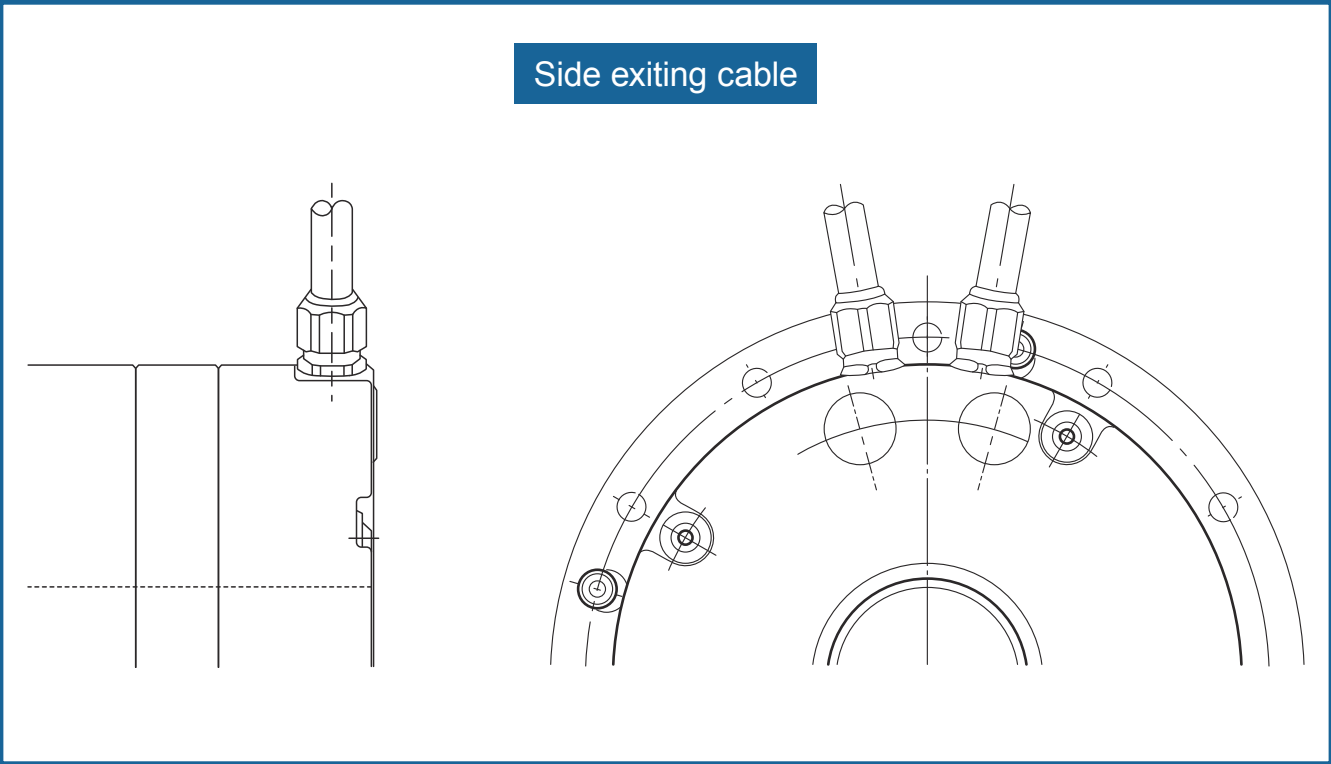

Motor Specifications

Item		Type	PMAC08	PMAB09	PMAB12	PMAB15	PMAA21A
Combined servo amplifier ^{*1,2}	A6N series		MBDL■25N□	MCDL■35N□	MDDL■55N□	MEDL■83N□	MFDL■B3N□
	A6B series		MBDL■25B□	MCDL■35B□	MDDL■55B□	MEDL■83B□	MFDL■B3B□
	A6 series		MBDL■25S□	MCDL■35S□	MDDL■55S□	MEDL■83S□	MFDL■B3S□
Input power supply voltage		V	200	200	200	200	200
Rated output		W	163	251	406	754	1320
Limit for momentary peak torque ³	N·m		1.8	3.0	7.0	13	45
	kgf·m		0.18	0.31	0.71	1.33	4.59
Rated torque ^{3,4}	N·m		0.52	0.8	1.55	3.6	12.6
	kgf·m		0.053	0.082	0.158	0.367	1.29
Maximum speed ³		r/min	6000	5600	4800	4000	3000
Rated speed		r/min	3000	3000	2500	2000	1000
Limit for momentary peak current ³		A	6.5	8.9	19	29	75
Rated current ^{3,4}		A	2.1	2.5	4.2	7.8	20
Torque constant ³	N·m/A		0.35	0.41	0.44	0.54	0.72
	kgf·m/A		0.036	0.042	0.045	0.055	0.073
Inductive voltage constant ⁵		V/(r/min)	0.037	0.043	0.046	0.057	0.075
Phase resistance (20°C)		Ω	1.43	1.2	0.33	0.19	0.028
Phase inductance		mH	2.5	3.0	1.4	1.2	0.29
Moment of Inertia The values in parentheses are for the models equipped with a brake.	GD ² /4	x 10 ⁻⁴ kg·m ²	0.734 (0.828)	1.78 (2.16)	6.45 (6.83)	15.8 (19.8)	125 (141)
	J	x 10 ⁻⁴ kgf·cm ²	7.49 (8.45)	18.2 (22.1)	65.8 (69.7)	161 (202)	1280 (1444)
Allowable radial load (static)	N		800	800	1200	2400	4500
	kgf		81.6	81.6	122	245	459
Allowable axial load (static)	N		1900	2400	3600	5000	14000
	kgf		194	245	367	510	1429
Rated radial load (At the rated speed)	N		175	185	233	530	1040
	kgf		17.9	18.9	23.8	54.1	106.1
Rated axial load (At the rated speed)	N		100	105	130	180	880
	kgf		10.2	10.7	13.3	18.4	89.8
Encoder type			Absolute encoder				
Encoder resolution	Single turn motor revolution		2 ¹⁷ (131072)				
	Multi revolution counter ⁶		2 ¹⁶ (65536)				
Mass The values in parentheses are for the models equipped with a brake.	kg		1.4 (1.5)	2.0 (2.1)	3.4 (3.8)	5.5 (6.2)	17.5 (19.7)
Ambient environment specification		Operating temperature: 0 to 40°C/Storage temperature:-20 to 60°C Operating/storage humidity: 20 to 80% RH (non-condensing) Vibration resistance: 25 m/s ² (frequency: 10 to 400 Hz) / impact resistance: 300 m/s ² ⁷ No dust, metal powder, corrosive gas, flammable gas, oil mist, or other similar material. Place indoors without being exposed to direct sunlight. Altitude: 1,000 m or less					
Motor insulation		Insulation resistance: 100 MΩ (500 VDC) or higher Dielectric strength voltage: 1500 VAC/min Insulation class: A					
Mounting direction		Can be installed in any direction.					
Protective structure		Totally enclosed self-cooled type (IP54)					

The values in the table above show typical values.

*1: ■ is replaced with the symbol that indicates whether to enable the safety function.

T: Compatible with the safety function (Not available in the A6 SE, SG series)

N: Without the safety function

*2: □ is replaced with the symbol that indicates the compatible communication.

E: Position-control type (combination with the type not equipped with the safety function)

F: Multi-function type (combination with the type equipped with the safety function)

G: Modbus communication type (only for the A6 series) (combination with the type not equipped with the safety function)

*3: Typical characteristics when used with the recommended sinusoidal amplifier

*4: This is the value for saturated temperature when installed on the aluminum heatsink of the following size:

PMAC08: 320 x 320 x 16 [mm] PMAB09: 350 x 350 x 18 [mm] PMAB12: 400 x 400 x 20 [mm] PMAB15: 500 x 500 x 25 [mm] PMAA21A: 650 x 650 x 30 [mm]

*5: This is the value of the phase EMF constant multiplied by 3.

*6: The range of the multi revolution detector is from -32768 to 32767.

*7: This value is not ensured if vibrations or shocks are applied for hours or continuously.

Operable Range

PMAC08/MINAS A6 (MBDL□25■)

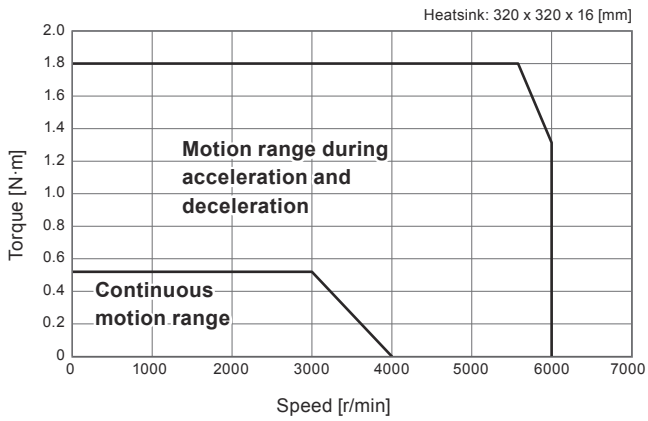

PMAB09/MINAS A6 (MCDL□35■)

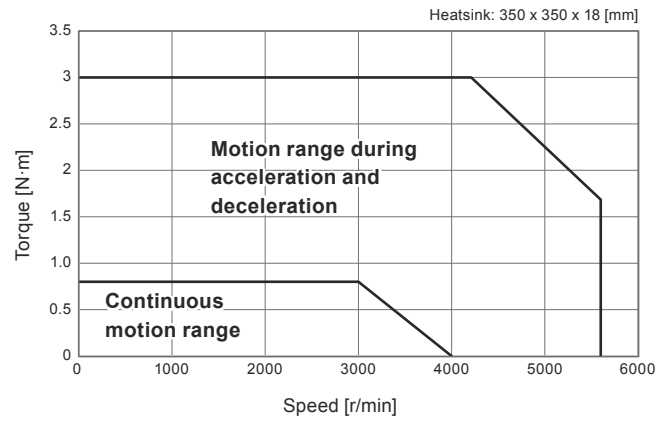

PMAB12/MINAS A6 (MDDL□55■)

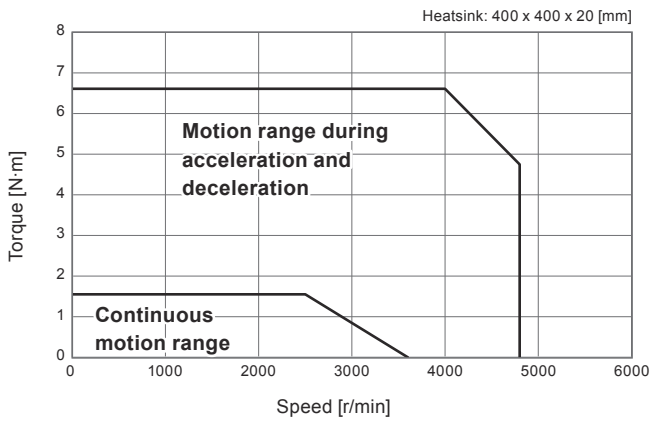

PMAB15/MINAS A6 (MEDL□83■)

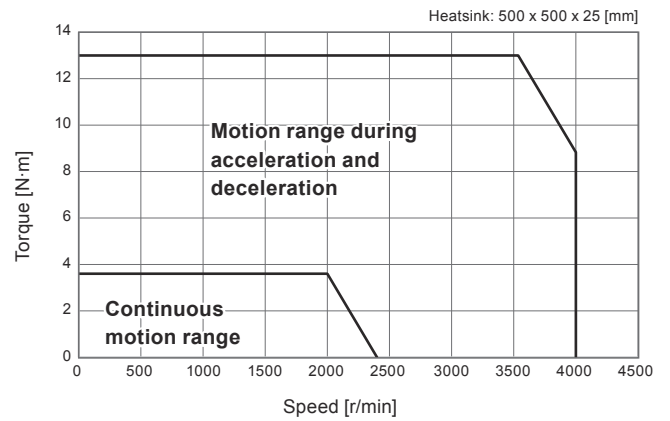

PMAA21A/MINAS A6 (MFDL□B3■)

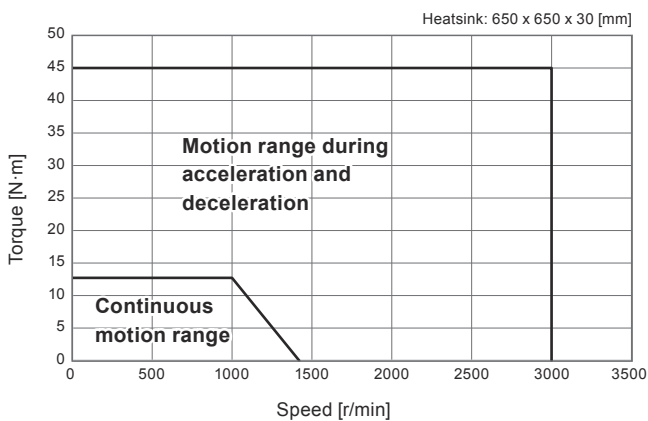

External Dimensions

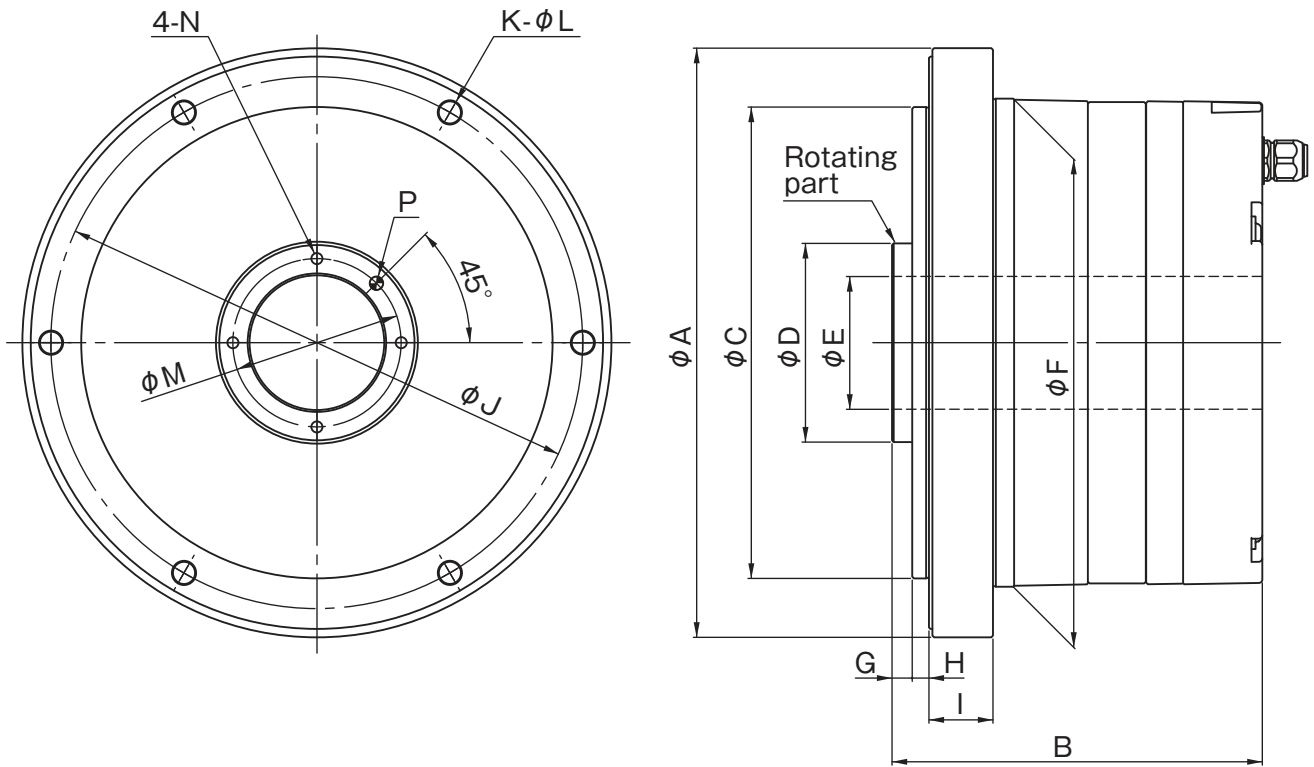

Note) For details of the external dimensions, refer to the delivery specification drawing issued by HDS.

(Unit: mm)

Dimension	PMAC08	PMAB09	PMAB12	PMAB15	PMAA21A
φA	94	114	146	175	247
B	89	88.5	95.5	110	157
φC	75 h7	90 h7	114 h7	140 h7	200 h7
φD	28 h6	34 h6	43 h6	59 h6	88 h6
φE (hollow diameter)	16	22	30	40	60
φF	77 h7	94 h7	122 h7	145 h7	210 h7
G	5	5	5	6	8
H	5	5	5	5	8
I	13	13	15	19	39
φJ	84	102	132	158	226
K	6	6	6	6	8
φL	3.4	4.5	5.5	6.6	9.0
φM	22	28	36	50	74
N	M3X6	M3X6	M3X6	M4X8	M5X10
P	φ3 H7X5	φ3 H7X5	φ3 H7X5	φ4 H7X7	φ5 H7X8

Mechanical Accuracy

The mechanical accuracy of the PMA series motor output shaft and of the mounting flange are shown below:

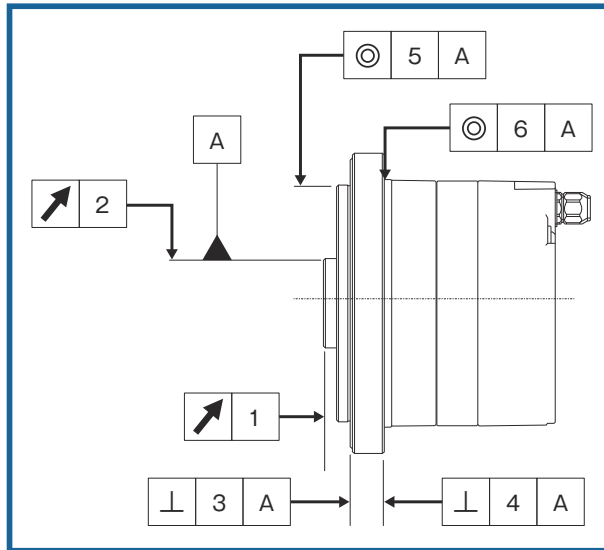

(Unit: mm)

Accuracy Item	PMAC08	PMAB09	PMAB12	PMAB15	PMAA21A
1. Output shaft surface runout	0.020	0.020	0.020	0.040	0.040
2. Output shaft radial runout	0.020	0.020	0.020	0.040	0.040
3. Mounting surface squareness to the output shaft	0.080	0.080	0.080	0.090	0.100
4. Mounting surface squareness to the output shaft	0.060	0.065	0.065	0.085	0.090
5. Concentricity between the output shaft and actuator mounting diameter	0.050	0.050	0.050	0.050	0.060
6. Concentricity between the output shaft and actuator mounting diameter	0.045	0.045	0.045	0.055	0.065

System use case

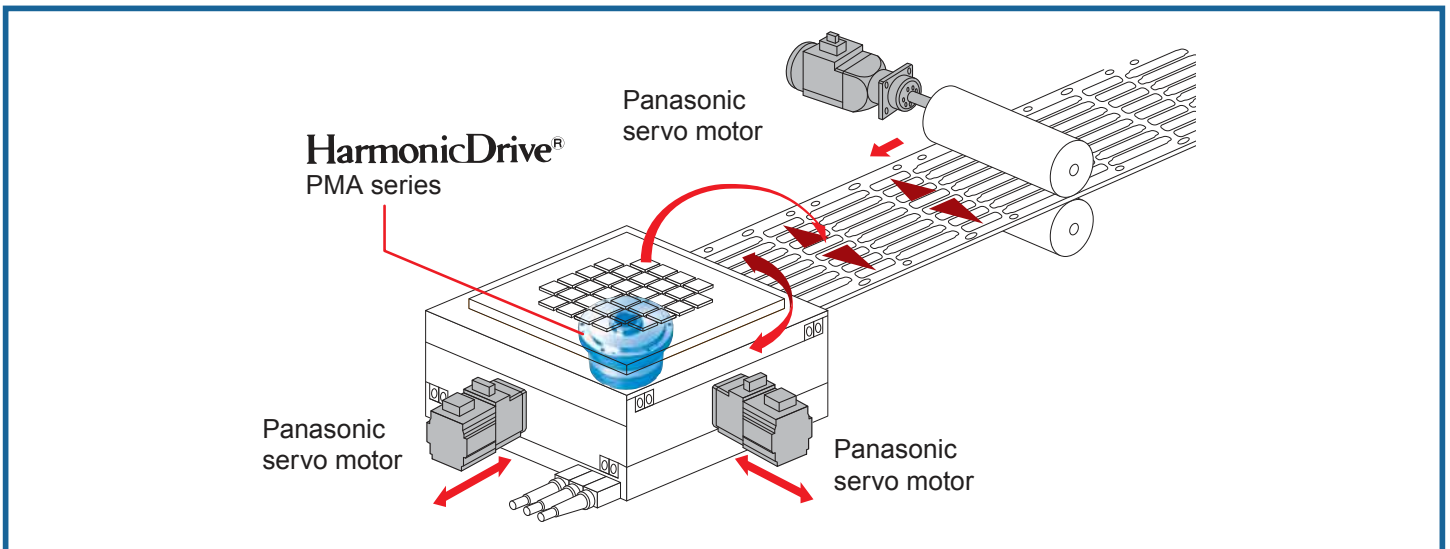

■ Please contact our sales department with any questions.

Head Office

Ichigo Omori Building 7F, 6-25-3 Minami-Oi,
Shinagawa-ku, Tokyo 140-0013 JAPAN
Phone: +81-3-5471-7800 / FAX: +81-3-5471-7811

Tokyo Office

Ichigo Omori Building 4F, 6-25-3 Minami-Oi,
Shinagawa-ku, Tokyo 140-0013 JAPAN
Phone: +81-3-5471-7830 / FAX: +81-3-5471-7836

Tokyo Office, Kitakanto Team

Ichigo Omori Building 4F, 6-25-3 Minami-Oi,
Shinagawa-ku, Tokyo 140-0013 JAPAN
Phone: +81-3-6410-8485 / FAX: +81-3-6410-8486

Koshin Office

1856-1 Hotakamaki, Azumino-shi, Nagano
399-8305 JAPAN
Phone: +81-263-83-6910 / FAX: +81-263-83-6911

Chubu Office

TM21-2F, 21 Terugaoka, Meito-ku, Nagoya-shi,
Aichi 465-0042 JAPAN
Phone: +81-52-773-7451 / FAX: +81-52-773-7462

Kansai Office

Shin-Osaka Ueno Toyo Building 3F, 7-4-17 Nishi-nakajima,
Yodogawa-ku, Osaka-shi, Osaka 532-0011 JAPAN
Phone: +81-6-6885-5720 / FAX: +81-6-6885-5725

Kyushu Office

NMF Hakata-ekimae Building 7F, 1-15-20 Hakata-ekimae,
Hakata-ku, Fukuoka-shi, Fukuoka 812-0011 JAPAN
Phone: +81-92-451-7208 / FAX: +81-92-481-2493

Overseas Division

1856-1 Hotakamaki, Azumino-shi, Nagano
399-8305 JAPAN
Phone: +81-263-83-6935 / FAX: +81-263-83-6901

Hataka Plant

1856-1 Hotakamaki, Azumino-shi, Nagano
399-8305 JAPAN
Phone: +81-263-83-6935 / FAX: +81-263-83-6901



"HarmonicDrive" is a trademark of Harmonic Drive Systems Inc.

The academic or generic term of our "HarmonicDrive" products is "strain wave gearing".

The company name and product name described in this document are trademarks or registered trademarks generally.

<http://www.hds.co.jp/>



Registered Trademark in Japan