

HarmonicDrive®

Flat Hollow Shaft AC Servo Motor

HMA series



The flat and hollow-shaft AC servo motor has been added to the standard lineup.

Features of our products are compact size, flat shape, and hollow shaft, and the servo motor that has these features has been added to our product lineup as the standard product.

The device configuration containing the hollow shaft reduces the size and cost of the mechanism.

Features

- The hollow shaft design provides the piping/wiring being layout on center of rotation without offsetting the motor.
- The flat structure reduces the size of the device configuration.
- A wide variety of five models with the rated output from 163 to 1320 W has been added to the lineup.
- Integrated brake option is available without dimension change.

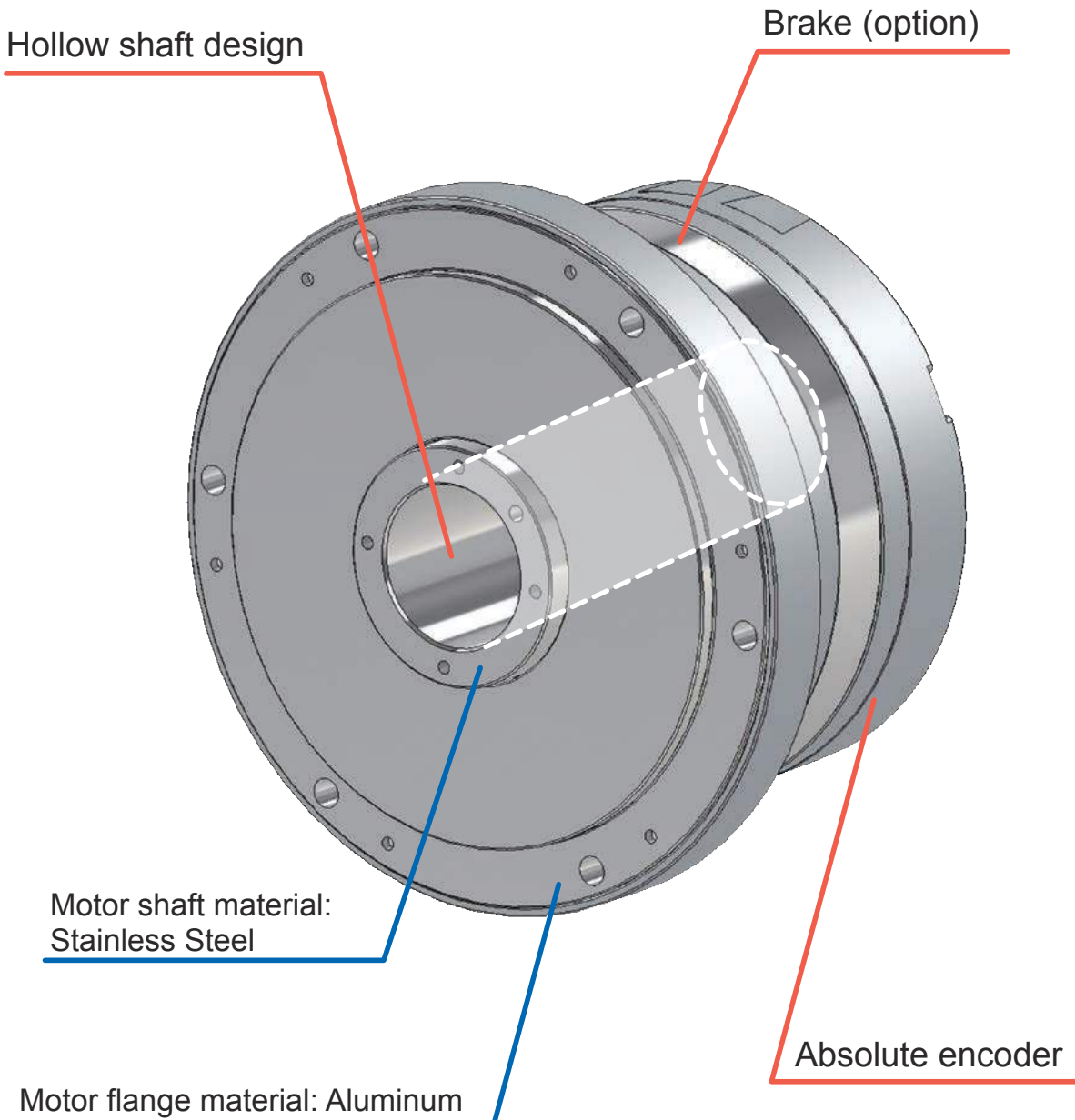

Ordering Code

HMA **B** **09** **A** **200** – **10** **S17b** **A** – **C** – **SP**
 (1) (2) (3) (4) (5) (6) (7) (8) (9)(10) (11)

(1)	Model name	AC servo motor HMA series
(2)	Motor version Symbol	A: Size 21A B: Size 09, 12, 15 C: Size 08
(3)	Size	08, 09, 12, 15, 21A
(4)	Brake	A: Without brake B: With brake
(5)	Applied servo driver Input voltage	100: 100 VAC (Only size 09 is compatible with 100 VAC.) 200: 200 VAC

(6)	Encoder format	10: A-format 2.5 Mbps, 1:1 connection
(7)	Encoder type Resolution	S17b: 17-bit absolute encoder
(8)	Encoder phase angle	Phase difference between the motor U phase and the encoder origin A: 0 degrees
(9)	Connector specification	C : With standard connectors N : Without connectors
(10)	Option symbols	Y : Side exiting cable
(11)	Special specifications	No symbol: Standard product SP: Special-specification product

Option:

■ Side exiting cable (Symbol for option: Y)

Cables (motor cable and encoder cable) are exited from the side of the motor. Use this option when there is not enough space in the rear direction of housing when installing a motor in the device.

For size 08, contact us separately. Size 21A is not compatible.

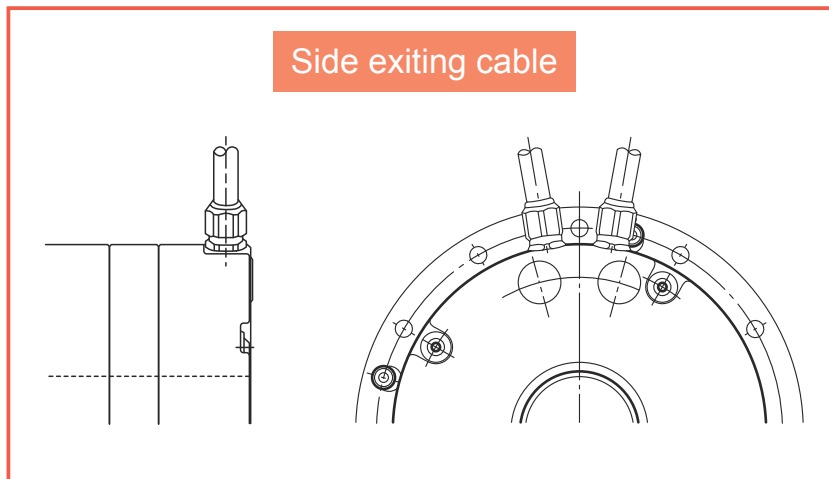

Motor Specifications

Item		Type	HMAC08	HMAB09		HMAB12	HMAB15	HMAA21A
Combined driver			HA-800□-3D-200	HA-800□-3D-200	HA-800□-6D/E-100	HA-800□-6D/E-200	HA-800□-24D/E-200	HA-800□-24D/E-200
Input power supply voltage	V		200	200	100	200	200	200
Rated output	W		163	251		406	754	1320
Instantaneous maximum torque ^{*1}	N·m		1.8	3.0		6.6	13	33
	kgf·m		0.18	0.31		0.67	1.33	3.37
Rated torque ^{*1, *2}	N·m		0.52	0.80		1.55	3.60	12.6
	kgf·m		0.053	0.082		0.158	0.367	1.29
Maximum speed ^{*1}	r/min		6000	5600	4800	4800	4000	3000
Rated speed	r/min		3000	3000		2500	2000	1000
Instantaneous maximum current ^{*1}	A		6.5	8.9	15.4	18	29	55
Rated current ^{*1, *2}	A		2.1	2.5	4.3	4.2	7.8	20.0
Torque constant ^{*1}	N·m/A		0.35	0.41	0.24	0.44	0.54	0.72
	kgf·m/A		0.036	0.042	0.024	0.045	0.055	0.073
EMF constant ^{*3}	V/(r/min)		0.037	0.043	0.025	0.046	0.057	0.075
Phase resistance (20°C)	Ω		1.43	1.2	0.4	0.33	0.19	0.028
Phase inductance	mH		2.5	3.0	1.0	1.4	1.2	0.29
Moment of Inertia () indicates the model equipped with a brake.	GD ² /4	×10 ⁻⁴ kg·m ²	0.734 (0.828)	1.78 (2.16)		6.45 (6.83)	15.8 (19.8)	125 (141)
	J	×10 ⁻⁴ kgf·cm·s ²	7.49 (8.45)	18.2 (22.1)		65.8 (69.7)	161 (202)	1280 (1444)
Allowable radial load (static)	N		800	800		1200	2400	4500
	kgf		81.6	81.6		122	245	459
Allowable axial load (static)	N		1900	2400		3600	5000	14000
	kgf		194	245		367	510	1429
Rated radial load (At the rated speed)	N		175	185		233	530	1040
	kgf		17.9	18.9		23.8	54.1	106.1
Rated axial load (At the rated speed)	N		100	105		130	180	880
	kgf		10.2	10.7		13.3	18.4	89.8
Encoder type			Absolute encoder					
Encoder resolution capability	Single turn motor revolution		2 ¹⁷ (131072)					
	Multi revolution counter ^{*4}		2 ¹⁶ (65536)					
Weight () indicates the model equipped with a brake.	kg		1.4 (1.5)	2.0 (2.1)		3.4 (3.8)	5.5 (6.2)	17.5 (19.7)
Ambient environment specification		Operating temperature: 0 to 40°C/Storage temperature: -20 to 60°C Operating/storage humidity: 20 to 80% RH (non-condensing) Vibration resistance: 25 m/s ² (frequency: 10 to 400 Hz) / impact resistance: 300 m/s ² No dust, metal powder, corrosive gas, flammable gas, oil mist, or other similar material. Place indoors without being exposed to direct sunlight. Altitude: 1,000 m or less						
Motor insulation		Insulation resistance: 100 MΩ (500 VDC) or higher Dielectric strength voltage: 1500 VAC/min Insulation class: A						
Mounting Direction		Can be installed in any direction.						
Protection structure		Totally enclosed self-cooled type (IP54)						

The values in the table above show typical values.

*1: They are typical characteristics in the case of combinations with our driver (driven with the ideal sine wave).

*2: This is the value for saturated temperature when installed on the next aluminum heatsink of the following size:

HMAC08: 320 x 320 x 16 [mm], HMAB09: 350 x 350 x 18 [mm], HMAB12: 400 x 400 x 20 [mm], HMAB15: 500 x 500 x 25 [mm], HMAA21A: 650 x 650 x 30 [mm]

*3: This is the value of the phase EMF constant multiplied by 3.

*4: The range of the multi revolution counter is from -32768 to 32767.

Operable Range

HMAC08

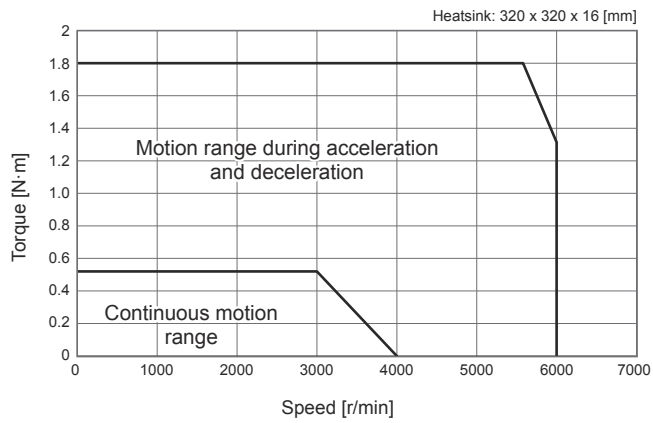

HMAB09

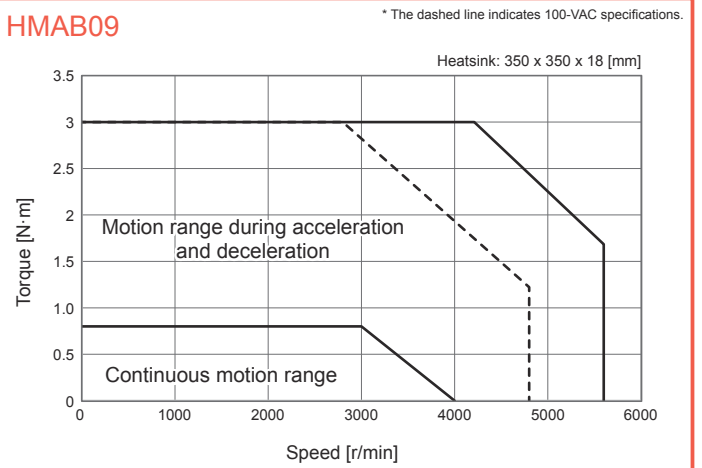

HMAB12

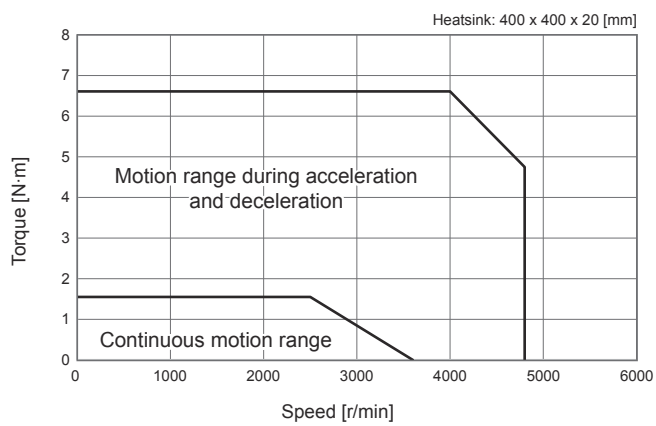

HMAB15

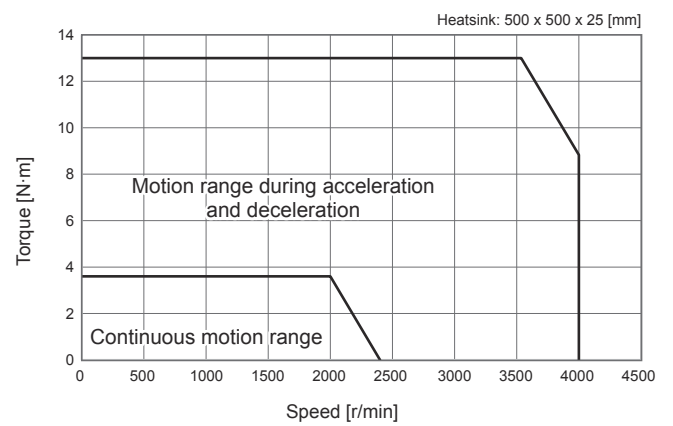

HMAA21A

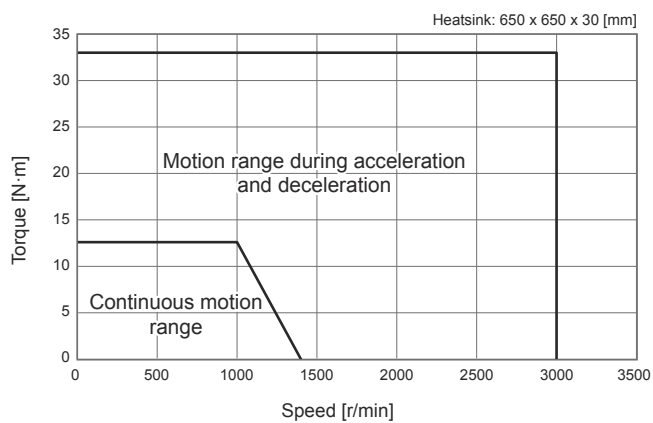

External Dimensions

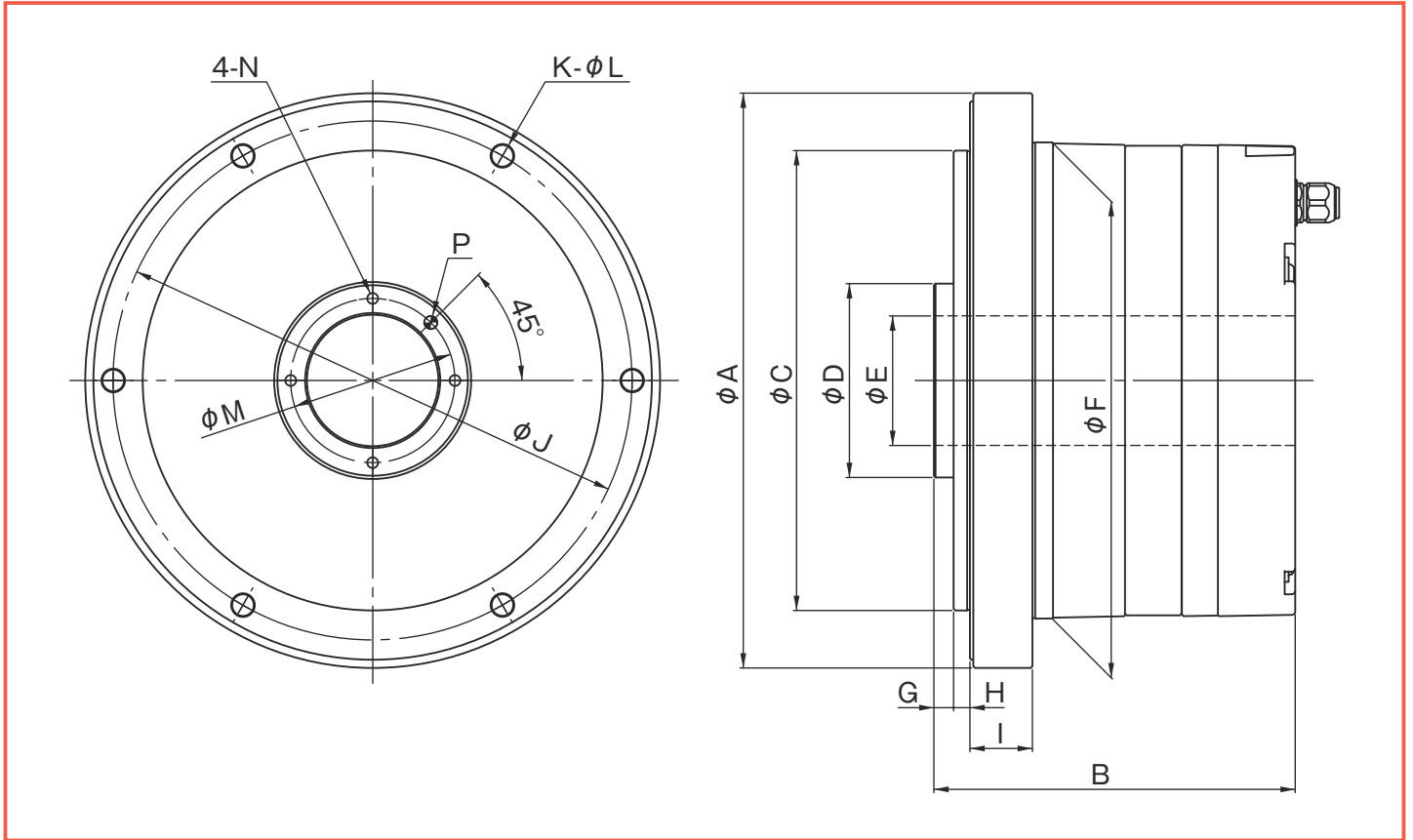

Dimension	HMAC08	HMAB09	HMAB12	HMAB15	HMAA21A
φA	94	114	146	175	247
B	89	88.5	95.5	110	157
φC	75 h7	90 h7	114 h7	140 h7	200 h7
φD	28 h6	34 h6	43 h6	59 h6	88 h6
φE (hollow diameter)	16	22	30	40	60
φF	77 h7	94 h7	122 h7	145 h7	210 h7
G	5	5	5	6	8
H	5	5	5	5	8
I	13	13	15	19	39
φJ	84	102	132	158	226
K	6	6	6	6	8
φL	3.4	4.5	5.5	6.6	9.0
φM	22	28	36	50	74
N	M3X6	M3X6	M3X6	M4X8	M5X10
P	φ3 H7X5	φ3 H7X5	φ3 H7X5	φ4 H7X7	φ5 H7X8

(Unit: mm)

Mechanical Accuracy

The mechanical accuracy of the HMA series motor output shaft and of the mounting flange are shown below:

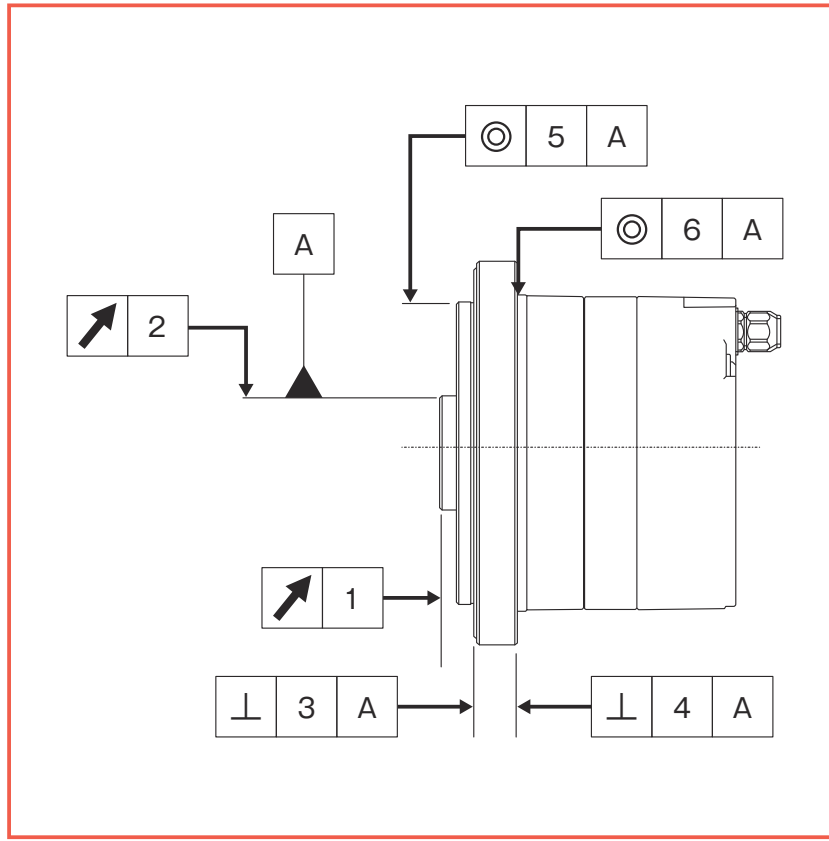

Accuracy Item	HMAC08	HMAB09	HMAB12	HMAB15	HMAA21A
1. Output shaft surface runout	0.020	0.020	0.020	0.040	0.040
2. Output shaft radial runout	0.020	0.020	0.020	0.040	0.040
3. Mounting surface squareness to the output shaft	0.080	0.080	0.080	0.090	0.100
4. Mounting surface squareness to the output shaft	0.060	0.065	0.065	0.085	0.090
5. Concentricity between the output shaft and actuator mounting diameter	0.050	0.050	0.050	0.050	0.060
6. Concentricity between the output shaft and actuator mounting diameter	0.045	0.045	0.045	0.055	0.065

(Unit :mm)



■ Please contact our sales department with any questions.

Head Office

Ichigo Omori Building 7F, 6-25-3 Minami-Oi,
Shinagawa-ku, Tokyo 140-0013 JAPAN
Phone: +81-3-5471-7800 / FAX: +81-3-5471-7811

Overseas Division

1856-1 Hotakamaki, Azumino-shi, Nagano
399-8305 JAPAN
Phone: +81-263-83-6935 / FAX: +81-263-83-6901

Tokyo Office

Ichigo Omori Building 4F, 6-25-3 Minami-Oi,
Shinagawa-ku, Tokyo 140-0013 JAPAN
Phone: +81-3-5471-7830 / FAX: +81-3-5471-7836

Tokyo Office, Kitakanto Team

Ichigo Omori Building 4F, 6-25-3 Minami-Oi,
Shinagawa-ku, Tokyo 140-0013 JAPAN
Phone: +81-3-6410-8485 / FAX: +81-3-6410-8486

Koshin Office

1856-1 Hotakamaki, Azumino-shi, Nagano
399-8305 JAPAN
Phone: +81-263-83-6910 / FAX: +81-263-83-6911

Chubu Office

TM21-2F, 21 Terugaoka Meito-ku, Nagoya-shi,
Aichi 465-0042 JAPAN
Phone: +81-52-773-7451 / FAX: +81-52-773-7462

Kansai Office

Shin-Osaka Ueno Toyo Building 3F, 7-4-17 Nishi-nakajima,
Hakata-ku, Fukuokashi, Fukuoka 812-0011 JAPAN
Phone: +81-6-6885-5720 / FAX: +81-6-6885-5725

Kyushu Office

NMF Hakata-ekimae Building 7F, 1-15-20 Hakata-ekimae,
Hakata-ku, Fukuokashi, Fukuoka 812-0011 JAPAN
Phone: +81-92-451-7208 / FAX: +81-92-481-2493

Hotaka Plant

1856-1 Hotakamaki, Azumino-shi, Nagano
399-8305 JAPAN
Phone: +81-263-83-6800 / FAX: +81-263-83-6901

Harmonic Drive AG

Hoenbergstrasse 14 D-65555 Limburg a.d. Lahn
GERMANY
Phone: +49-6431-5008-0 / FAX: +49-6431-5008-119

Harmonic Drive L.L.C.

247 Lynnfield Street, Peabody, MA 01960
U.S.A.
Phone: +1-978-532-1800 / FAX: +1-978-532-9406

Harmonic Drive Systems (Shanghai) Co., Ltd.

Rm206, 1#, No.641, Tianshan Rd, Changning District,
Shanghai, 200336, CHINA
Phone: +86-21-6237-5656 / FAX: +86-21-3250-7268

<http://www.hds.co.jp>

"HarmonicDrive" is a trademark of Harmonic Drive Systems Inc.
The academic or generic term of our "HarmonicDrive" products is "strain wave gearing."

