

HarmonicDrive®

Flat Shape and Hollow Shaft Design AC Servo Actuator FHA-C Series High Positioning Accuracy FHA-C-PR Type (Option)

To the AC servo actuator FHA-C series,
the high positioning accuracy specification (option) has been added
to its lineup.

The high positioning accuracy specification type has been added to the AC Servo Actuator FHA-C series, so that its lineup has been further enriched.

We standardized the repeatability and bi-directional positioning accuracies of the FHA-C series to offer you an optimal use for your various types of applications requiring further accurate positioning. We recommend this type for alignment application that requires high positioning accuracy.



Standardization of Repeatability and Bi-directional Positioning Accuracy

■ Repeatability

(Unit: arc-sec)

Gear ratio \ Type	FHA-17C-PR	FHA-25C-PR	FHA-32C-PR	FHA-40C-PR
1:50	±5	±5	±4	±4
1:100				
1:160				

■ Bi-directional Positioning Accuracy

(Unit: arc-sec)

Gear ratio \ Type	FHA-17C-PR	FHA-25C-PR	FHA-32C-PR	FHA-40C-PR
1:50	75	60	50	50
1:100	30	25	20	20
1:160				

The FHA-C-PR type is optimal for the alignment application because it enables the high positioning accuracy.

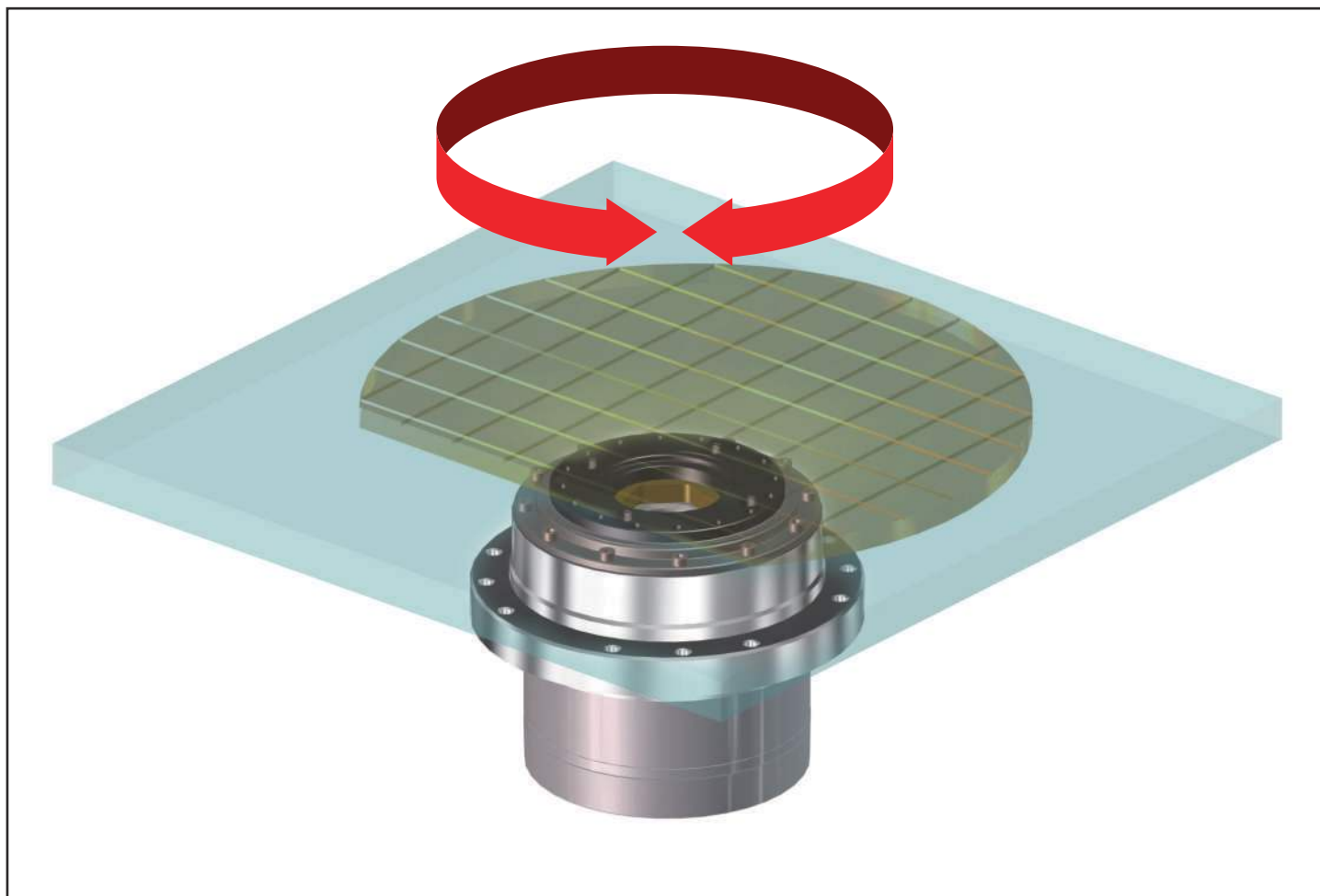

■ Ordering Code

FHA - 17 C - 50 - E 250 - PR

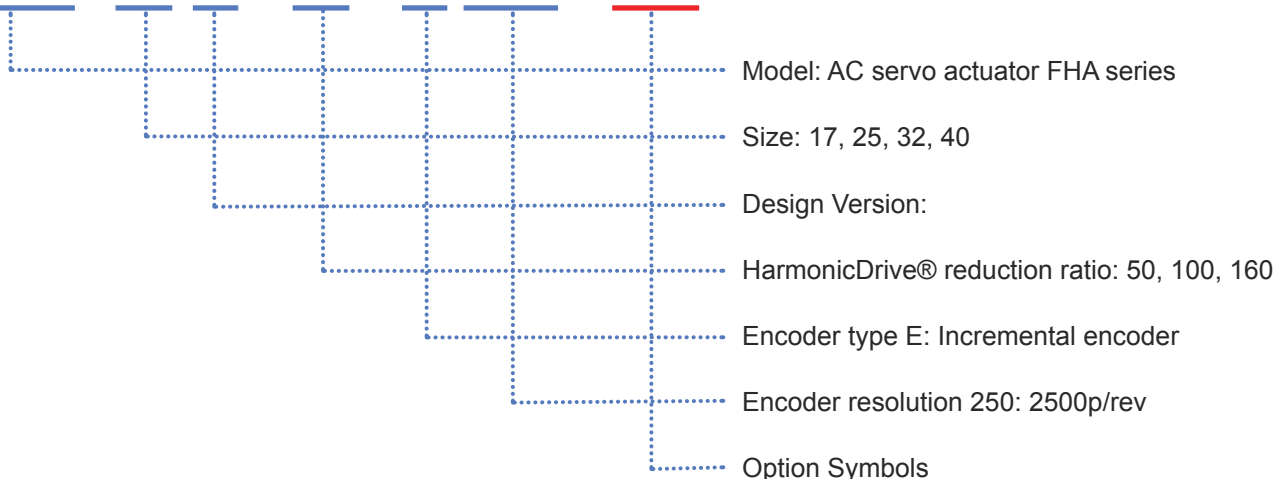

■ Details of special options

Option specification	Option descriptions	Symbol
Power supply voltage 100V	Applicable to FHA-17C / 25C / 32C	A
Motor shaft brake	For holding motor shaft	B
With connector	For motor (IP-20), for encoder (IP-40)	C
Cable extension	5m length for each motor cable and encoder cable	F5

Option specification	Option descriptions	Symbol
Cable exit direction	from back bracket face	K
Position sensor	Origin and end limits	L
High positioning accuracy	Standardization of Repeatability and Bi-directional positioning accuracy	PR

Note: Contact our sales and marketing office when using the options in the combinations of two or more types.

■ Specification

The FHA-C-PR type actuator specification is shown below.

"200V" and "100V" in the table are referred to as the 200V specification (standard) and the 100V specification (option), respectively.

Item	Type	FHA-17C-xx-E250-PR			FHA-25C-xx-E250-PR			FHA-32C-xx-E250-PR			FHA-40C-xx-E250-PR			
		50	100	160	50	100	160	50	100	160	50	100	160	
Maximum torque	N•m	39	57	64	150	230	260	281	398	453	500	690	820	
	kgf•m	4.0	5.8	6.5	15.3	23.5	26.5	28.7	40.6	46.2	51	70.4	83.7	
Maximum speed	r/min	96	48	30	90	45	28	80	40	25	70	35	22	
Torque constant	200V	N•m/A	21	42	67	22	45	72	27	54	86	31	64	102
		kgf•m/A	2.1	4.3	6.8	2.3	4.6	7.3	2.8	5.5	8.8	3.2	6.5	10.4
	100V	N•m/A	11	21	33	11	22	36	13	27	43	-	-	-
		kgf•m/A	1.1	2.2	3.4	1.2	2.3	3.7	1.4	2.8	4.4	-	-	-
Maximum current ²	200V	A	2.1	1.6	1.1	7.3	5.6	4.0	11.4	8.0	5.9	17.3	11.8	9.0
	100V	A	4.2	3.2	2.2	15	11	8.0	23	16	12	-	-	-
EMF voltage constant	200V	V/(r/min)	2.3	4.7	7.5	2.5	5.1	8.1	3.0	5.9	9.5	3.6	7.2	11.4
	100V	V/(r/min)	1.2	2.4	3.8	1.3	2.6	4.1	1.5	3.0	4.8	-	-	-
Phase resistance	200V	Ω (20°C)	7.9			2.6			1.0			0.73		
	100V	Ω (20°C)	2.0			0.65			0.25			-		
Phase inductance	200V	mH	6.0			2.6			1.3			1.5		
	100V	mH	1.5			0.65			0.33			-		
Moment of inertia	(GD ² /4)	kg•m ²	0.21	0.83	2.1	0.90	3.5	9.2	2.1	8.2	21	5.5	22	56
	(J)	kgf•cm•s ²	2.1	8.5	21	9	37	94	21	84	215	56	223	569
Reduction ratio		1:50	1:100	1:160	1:50	1:100	1:160	1:50	1:100	1:160	1:50	1:100	1:160	
Permissible radial load	kN	2.9			4.9			9.5			14.7			
	kgf	300			500			970			1500			
Permissible axial load	kN	9.8			14.7			24.5			39.2			
	kgf	1000			1500			2500			4000			
Max. moment load	N•m	188			370			530			690			
	kgf•m	19			38			54			70			
Moment stiffness	N•m/rad	220×10 ³			490×10 ³			790×10 ³			1400×10 ³			
	kgf•m/arc-min	6.5			15			23			42			
One-way positioning accuracy	arc-sec	60	40	40	40	30	30	40	30	30	40	30	30	
Repeatability	arc-sec	±5			±5			±4			±4			
Bi-directional positioning accuracy	arc-sec	75	30	30	60	25	25	50	20	20	50	20	20	
Motor position detector		2500 counts / revolution												
Output shaft resolution (with quadrature encoder) ³	Pulse/rev	500,000	1,000,000	1,600,000	500,000	1,000,000	1,600,000	500,000	1,000,000	1,600,000	500,000	1,000,000	1,600,000	
Mass	kg	2.8			4.7			7.1			13.6			
Protective structure		Totally enclosed self-cooling type (IP44)												
Environmental conditions		Operating temperature: 0 to 40°C/storage temperature: -20 to 60°C Operating humidity / storage humidity: 20 to 80%RH (no condensation) Vibration resistance: 24.5m/s ² (frequency: 10 to 400Hz) / shock resistance: 294 m/s ² Do not expose to dust, metal powder, corrosive gas, flammable gas, or oil mist. Use indoors, and do not expose to direct sunlight. Altitude: 1000 m or lower above sea level												
Motor insulation		Insulation resistance: 100MΩ or higher (500 VDC) Withstanding voltage: AC1500V/1min Insulation class: Type F												
Orientation		All position												
Combination servo driver	200V	HA-800*-3C-200			HA-800*-3C-200			HA-800*-6C-200			HA-800*-6C-200			
	100V	HA-800*-3C-100			HA-800*-6C-100			HA-800*-6C-100			-			

Note 1: The values in the table above are referred to as typical values for the output shaft.

Note 2: The value indicates the one when combined with the HA-800 driver.

Note 3: The output shaft resolutions are obtained by (motor encoder resolution x 4) x (reduction ratio)

External Dimension

Compared to the FHA-C series standard type, only the dimensions of L_1 and L_2 of the high positioning accuracy specification of the FHA-C-PR type differ as shown in the following drawing; however, the other dimensions are the same as those of the standard type. Refer to the "General Catalog for Mechatronics Products," "FHA-C Series Technical Manual," and "Confirmation Drawing."

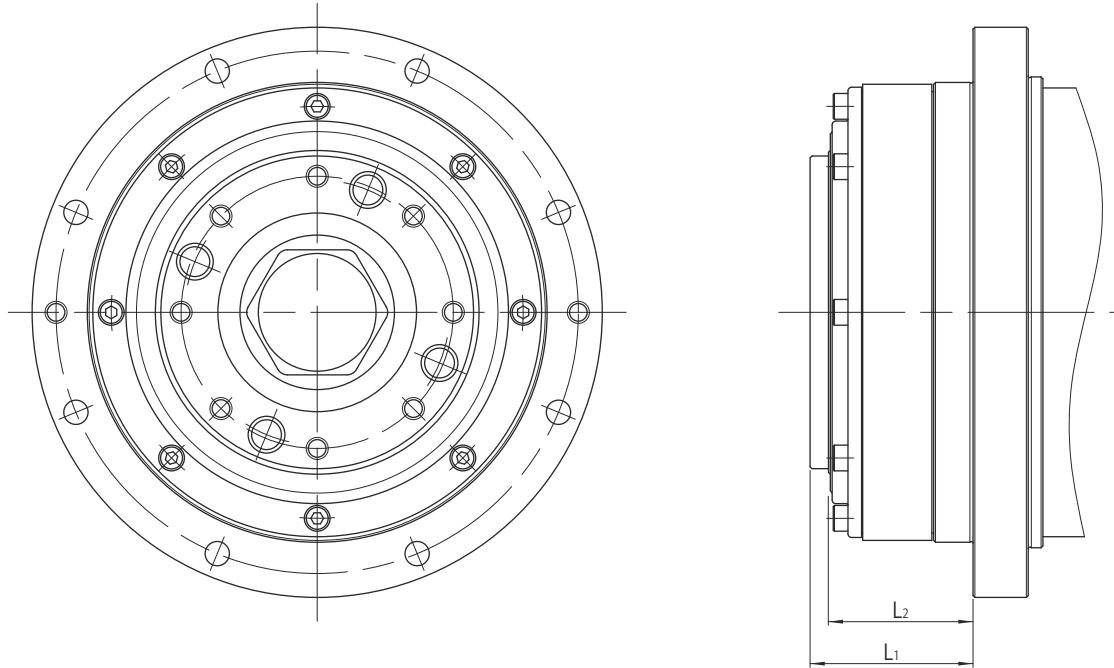

(Unit: mm)

Actuator model	FHA-17C-PR	FHA-25C-PR	FHA-32C-PR	FHA-40C-PR
Dimension L_1	35	44.3	46	58.5
Dimension L_2	29.5	39.3	41	51.5

Mechanical Accuracy

The FHA-C-PR type mechanical accuracies of the output shaft and mounting flange are shown below:

(Unit: mm)

Accuracy Item	FHA-17C-PR	FHA-25C-PR	FHA-32C-PR	FHA-40C-PR
1. Output shaft surface runout	0.010	0.012	0.012	0.014
2. Output shaft axial runout	0.010	0.012	0.012	0.014
3. Parallelism between output shaft and mounted surface	0.040	0.050	0.050	0.060
4. Concentricity between output shaft and fitting part	0.040	0.050	0.050	0.060

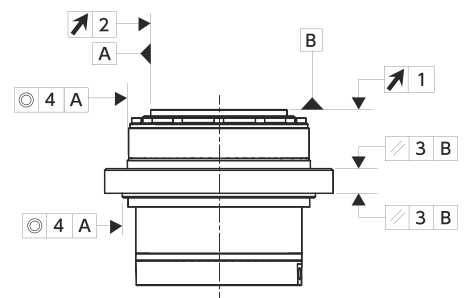

Note: For information on the measurement method, refer to the "FHA-C Series Technical Manual."

Note: Values are based on the Total Indicator Reading (T.I.R.).

* Please contact our sales representative or distributor office for more information.

	Head Office:	Ichigo Omori Building 7F, 6-25-3 Minami-Oi, Shinagawa-ku, Tokyo 140-0013 JAPAN Phone: +81-3-5471-7800 / FAX: +81-3-5471-7811
	Hotaka Plant:	1856-1 Hotakamaki, Azumino-shi, Nagano 399-8305 JAPAN Phone: +81-263-83-6800 / FAX: +81-263-83-6901
	Overseas Division:	1856-1 Hotakamaki, Azumino-shi, Nagano 399-8305 JAPAN Phone: +81-263-83-6935 / FAX: +81-263-83-6901
	Taiwan Representative Office:	G219, 11F., No.209, Sec.1, Civic Blvd., Datong Dist., Taipei City, Taiwan (R.O.C.) Phone: +886-2-2181-1640 / FAX: +886-2-2181-1641
	日商哈默納科股份有限公司 台灣代表人辦事處:	台北市大同區市民大道一段209號11樓 G219室 Phone: +886-2-2181-1640 / FAX: +886-2-2181-1641

"HarmonicDrive" is a trademark of Harmonic Drive Systems Inc. The academic or generic term of our "HarmonicDrive" products is "strain wave gearing." Harmonic Drive® trademark is registered in Japan, Korea and Taiwan.

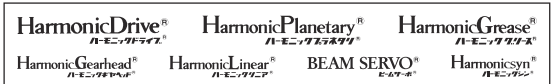

Registered Trademark in Japan
No. 1511-1R-FHAPR1/news23