

HarmonicDrive®

CSF-mini Series, Ultra Flat and High Stiffness Type

To the HarmonicDrive® CSF-mini series, **the ultra flat and high stiffness type has been added to its lineup.**

For the CSF-mini series, the unit type of the small size HarmonicDrive®, its lineup has been further enriched by developing the lightweight, ultra-flat, and high stiffness type. Compared to the conventional product of the CSF-mini series, flattening has been remarkably realized while the high stiffness has been implemented by adopting the cross roller bearing at the output flange.

It's time to think about introducing this series into the application for the compact and lightweight payload robot or the respective mechanical parts of the small machinery and equipment.

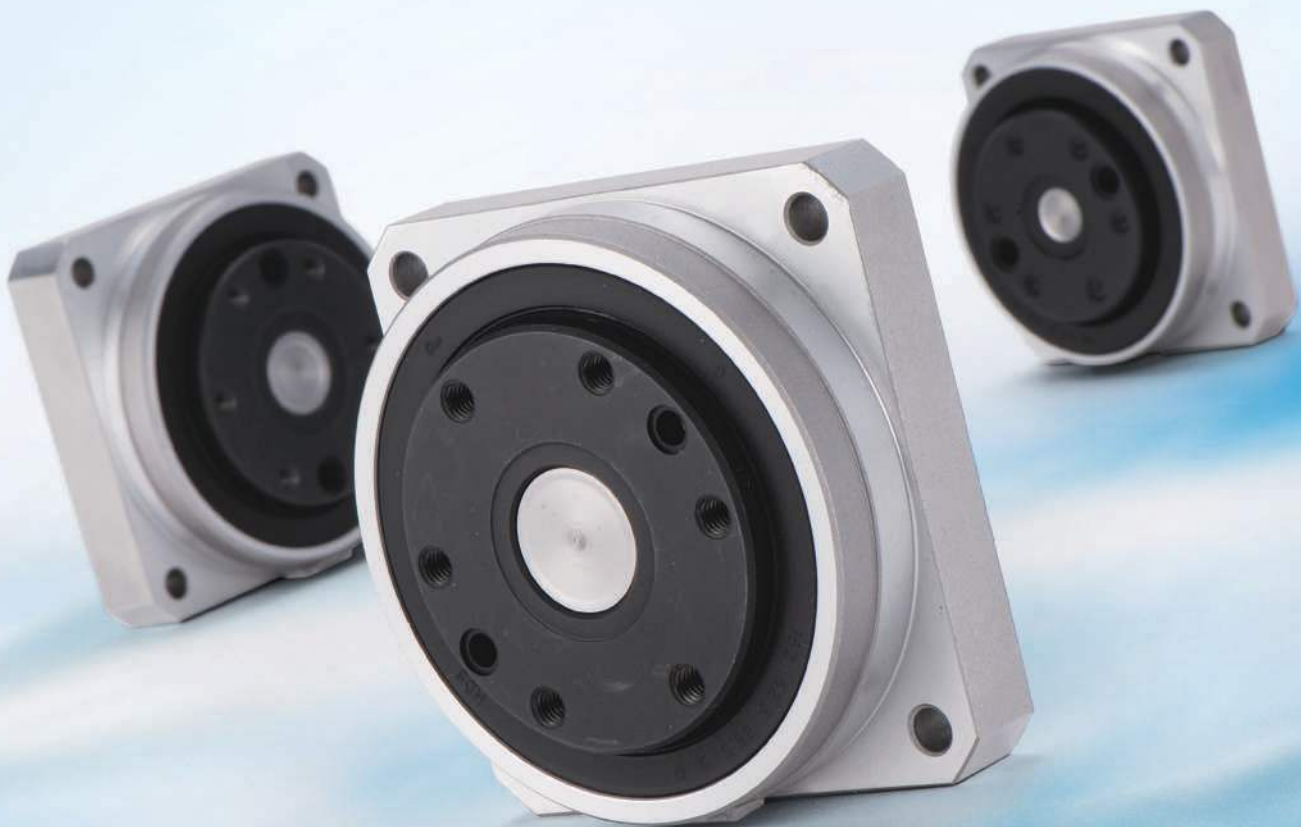

Feature

- The ultra flat structure enables compact design of the machine and the device.
- The adoption of the high stiffness cross roller bearing enables the direct support of the external load.
- The mounting flange is provided in accordance with the motor used by the customer.

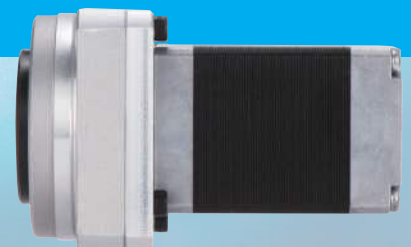

■ Example of motor installation

■ Model No. and Ordering Code

CSF - 14 - 100 - 2UP - Specification

Table 2-1

Model name	Size	Reduction ratio			Type	Special specifications
						-
CSF series	8	30	50	100	2UP (High stiffness)	Blank = standard product SP = Special specification for shape and performance (Including the motor mounting flange options)
	11	30	50	100		
	14	30	50	100		

■ Special specification

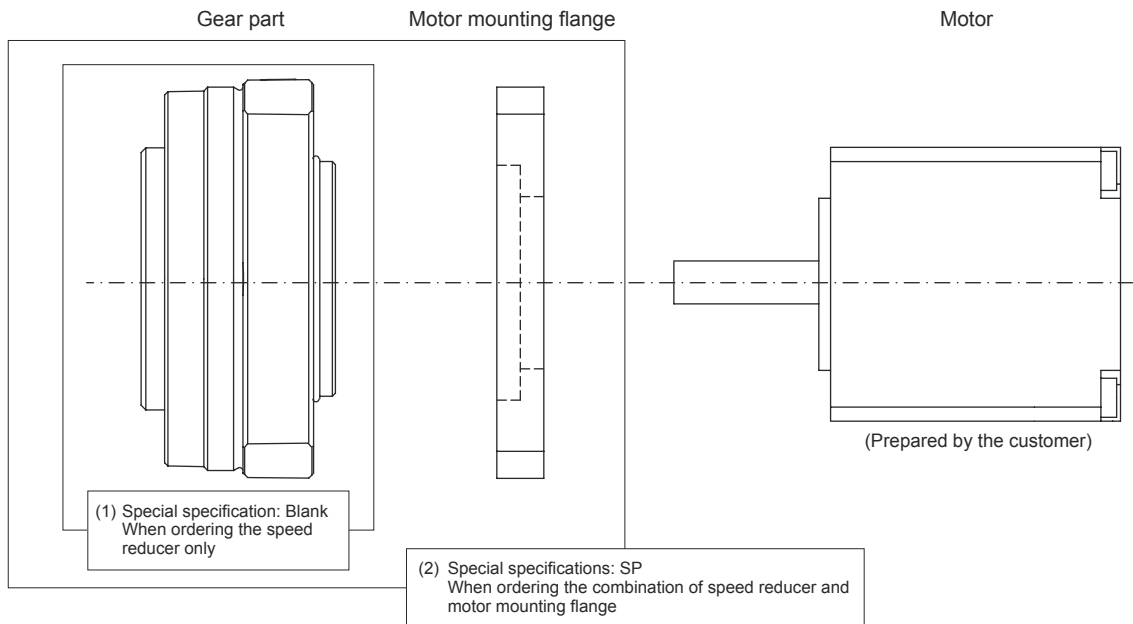

* The motor mounting flange is designed and sold as an option. Please let us know the required dimension as shown in Figure 11-1 on page 11 when you need the flange design.

* Installations of the motor mounting flange and motor must be performed by the customer. For installation, refer to pages 8 through 10.

* The special specification: SP includes the other special specifications.

■ Rated Table

Table 2-2

Size	Reduction ratio	Rated torque at input speed 2000 r/min	Limit for repeated peak torque	Limit for average torque	Limit for momentary peak torque	Maximum Input Speed	Limit for average input speed	Moment of inertia (1/4GD ²)
		Nm	Nm	Nm	Nm	r/min	r/min	kgcm ²
8	30	0.9	1.8	1.4	3.3	8500	3500	4.0 × 10 ⁻³
	50	1.8	3.3	2.3	6.6			
	100	2.4	4.8	3.3	9.0			
11	30	2.2	4.5	3.4	8.5	8500	3500	1.5 × 10 ⁻²
	50	3.5	8.3	5.5	17			
	100	5.0	11	8.9	25			
14	30	4.0	9.0	6.8	17	8500	3500	4.0 × 10 ⁻²
	50	5.4	18	6.9	35			
	100	7.8	28	11	54			

(Note) For details about terms, refer to the technical manual in Harmonic Drive® General Catalog."

■ Main Roller Bearing Specifications

Precise cross roller bearing is built in the CSF-mini series 2UP type for the purpose of directly supporting external load (on the output side).

In order to fully demonstrate the performance of the unit type, check the maximum load moment load, cross roller bearing life, and static safety coefficient.

For details about the equations for the respective values, refer to technical manual in "Harmonic Drive® General Catalog."

■ Checking procedure

(1) Checking maximum load moment load (M max)

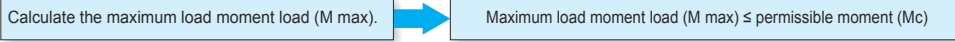

(2) Checking life

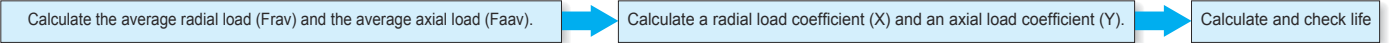

(3) Checking the static safety coefficient

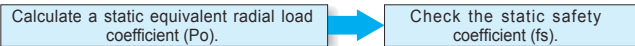

■ Main roller bearing specifications

Table 3-1

Size	Pitch circle	Offset	Basic rated load		Permissible moment load Mc	Moment stiffness Km
	dp	R	Basic dynamic rated load C	Basic static rated load Co		
	mm	mm	× 10 ² N	× 10 ² N	Nm	Nm/rad
8	35	12.9	58	80	15	2.0 × 10 ⁴
11	42.5	14	65	99	40	4.0 × 10 ⁴
14	54	14	74	128	75	8.0 × 10 ⁴

* The basic dynamic rated load is referred to as a constant static radial load so that the basic dynamic rated load of the bearing is to be a million rotations.

* The basic static rated load is referred to as a static load that provides a constant level contact stress (4kN/mm²) at the center of the contact side between the rolling element that bears the maximum load and the orbit.

* The permissible moment load is referred to as the maximum moment load that can be applied to the output bearing while the basic performance can be retained within the range of the maximum moment load that can be operable.

* The values of the moment stiffness are the reference values. The lower limit value is approximately 80% of the display value.

■ Lubrication

For the CSF-mini series 2UP type lubrication, the grease lubricant is used as a standard lubrication method. There is no need to inject or to apply grease upon installation since the products are shipped with the grease sealed. The greases below are used as the lubricants:

Table 3-2

Lubricated area	Gear part	Cross roller bearing
Lubricant names used	Harmonic Grease® SK-2	
Manufacturer	Harmonic Drive Systems Inc.	
Base oil	Refined oil	
Puffing agent	Lithium soap base	
Mixing consistency (25°C)	265 to 295	
Drop point	198°C	
Appearance	Green color	



External Dimensions

Figure 4-1

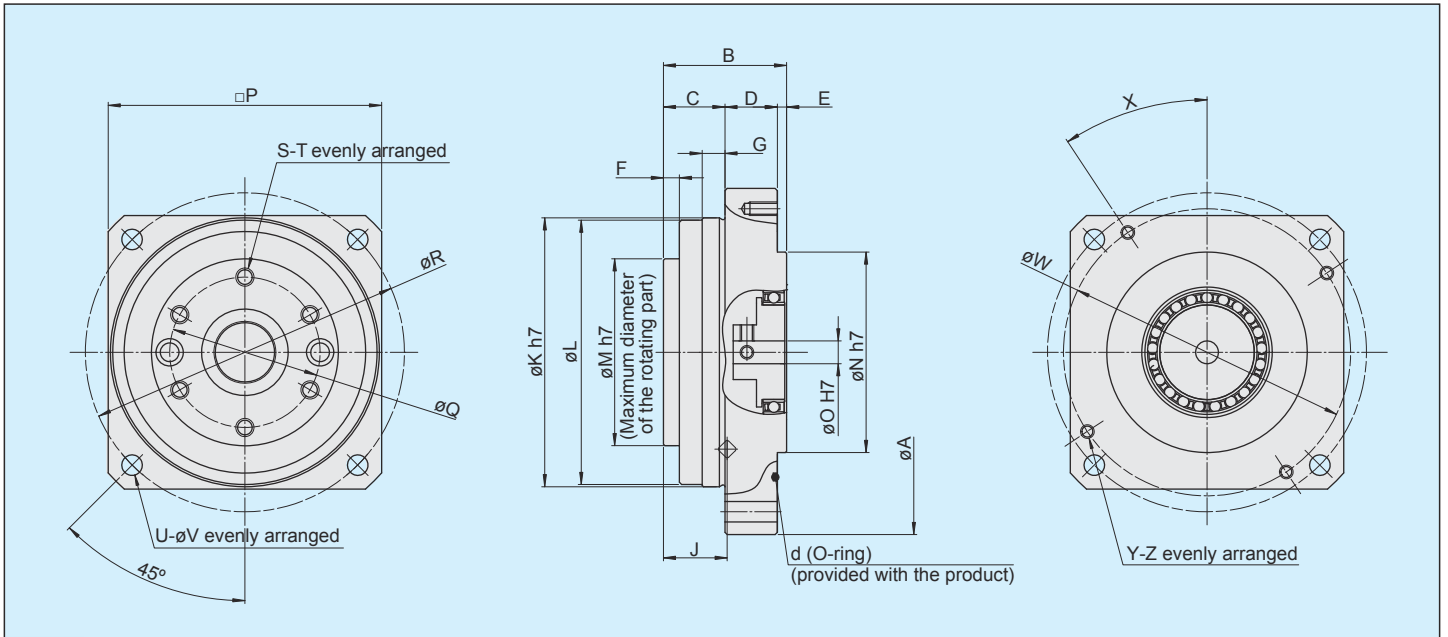

Dimension table

Table 4-1
Unit: mm

Symbol	Size	8	11	14
φA		66	80	100
B		24.8	27	33.5
C		13	13.5	18.5
D		9	11.5	12
E		2.8	2	3
F		3	3.5	3.5
G		5	5	8
H*		1.1 ^{0.3}	1.6 ^{0.7}	3.5 ^{0.8}
I		7.2	8.3	10.5
J		12.9	14	14
φK		49	59	74
φL		48	58	73
φM		33.5	41	52.5
φN		30	44	52
φO		5	5	8
□P		50±1	60±1	75±1
φQ		25.5	33	44
φR		58	70	88
S		6	6	6
T		M3 × 6	M4 × 5	M5 × 7
U		4	4	4
φV		3.5	4.5	5.5
φW		52	63	70.71
X		35°	33.5°	55°
Y		4	4	4
Z		M3 × 5	M3 × 6	M4 × 8
Mass (g)		200	330	620

Wave generator mounting dimension enlarged view diagram

Figure 4-2

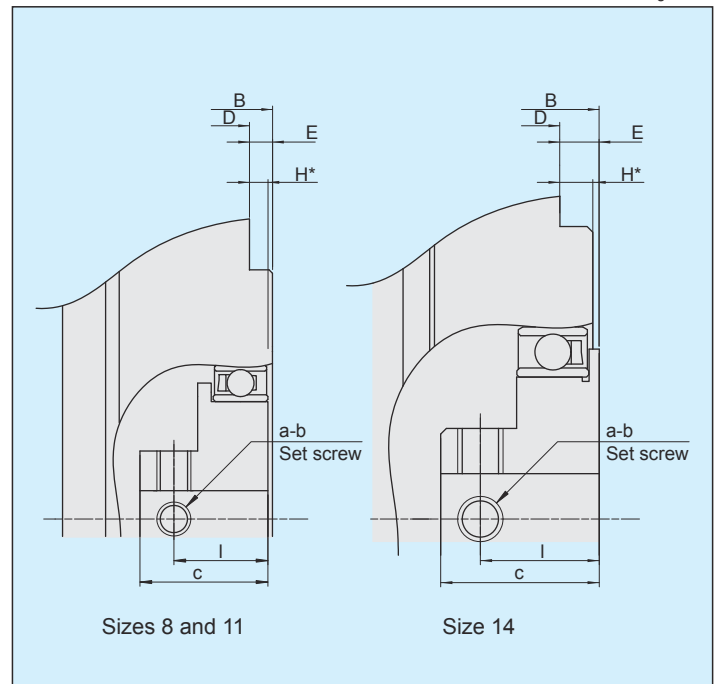

* Dimension H is the mounting position in the shaft direction and tolerance of the three parts (wave generator, flexspline, circular spline) comprising Harmonic-Drive®. Strictly observe these dimensions as they affect the performance and strength.

Table 4-2

Symbol	Size	8	11	14
a		2	2	2
b		M3×4	M3×4	M4×4
c		10.2	11.3	14
d		φ29.8×0.8	φ54.0×1.2	φ58.4×1.3

Wave Generator Hole Diameter Dimension

The hole diameter dimension (as shown in Table 4-1 on page 4, ϕO) can be changed in accordance with the shaft diameter of the mounting motor within the range shown in the table below:

Table 5-1
Unit: mm

Symbol \ Size	8	11	14
ϕO H7	2 to 8	3 to 8	4 to 10

- * The special specification is applied to the entire unit when a hole diameter is changed. For information on the dimensions, please contact our sales representatives.
- * The wave generator of a standard product is a rigid type (integral type). The Oldham type (self-aligning mechanism) is included in the special specification.

Mechanical Accuracy

By adopting the high accuracy and high stiffness cross roller bearing in the CSF-mini series 2UP, high mechanical accuracy is realized on the output side. The mechanical accuracy on the output side is shown below.

Figure 5-1

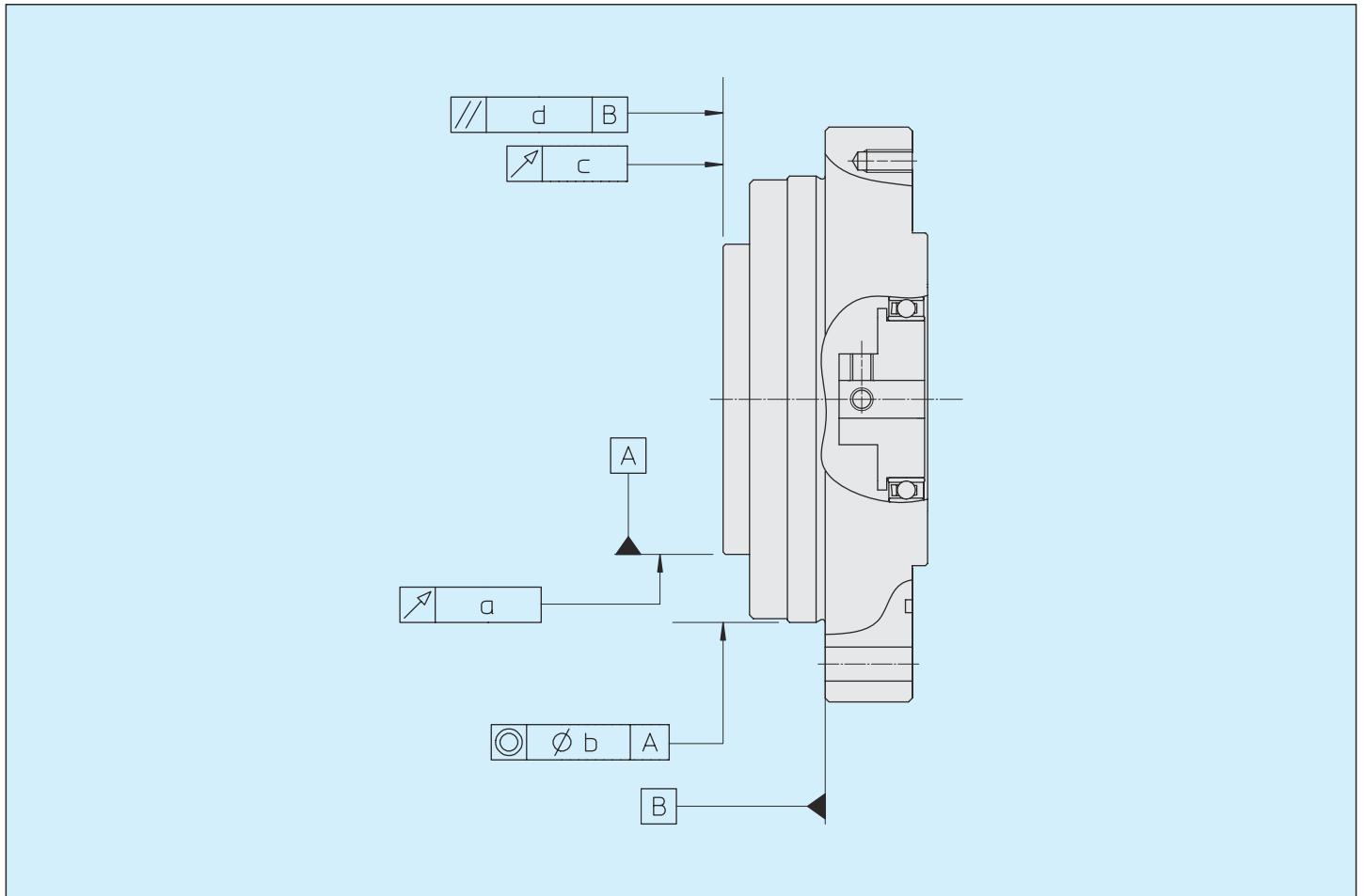

Table 5-2
Unit: mm

Symbol	Accuracy Item	Size		
		8	11	14
a	Output shaft axial runout	0.010		
b	Concentricity of the mounting pilot	0.040		
c	Output flange surface runout	0.010		
d	Parallelism between the mounting face and the output flange face	0.040		

(Note) Values are based on the Total Indicator Reading (T.I.R.).

Efficiency Characteristics

The efficiency varies depending on the following conditions.

- Reduction ratio
- Input rotating speed
- Load torque
- Temperature
- Lubrication condition (Lubricant type and amount)

Efficiency compensation coefficient

The value of efficiency drops when load torque is smaller than rated torque. Calculate the compensation coefficient K_e from graph 6-1 and calculate the value of efficiency with the reference to the efficiency compensation calculation formula.

Example: Calculate efficiency η (%) for the CSF-8-100-2UP under the following conditions:
 Input rotational speed 1000 r/min
 Load torque: 2.0 Nm

Lubrication method: Grease lubricant
 Lubricant temperature: 20°C

Torque ratio α is 0.83 since the rated torque for size 8 and reduction ratio 100 is 2.4 Nm. ($\alpha = 2.0 / 2.4 \approx 0.83$)

The efficiency compensation coefficient is calculated according to graph 6-1: $K_e = 0.99$

Efficiency η when load torque is 2.0 Nm is calculated: $\eta = K_e \cdot \eta_R = 0.99 \times 77\% = 76\%$

* When load torque is larger than rated torque, efficiency compensation coefficient $K_e = 1$.

Measuring condition

Table 6-1

Load torque	Rated torque indicated in the rated table		
	Lubrication condition	Grease lubrication	Name
		Applied amount	Appropriate applied amount

Efficiency compensation coefficient

Graph 6-1

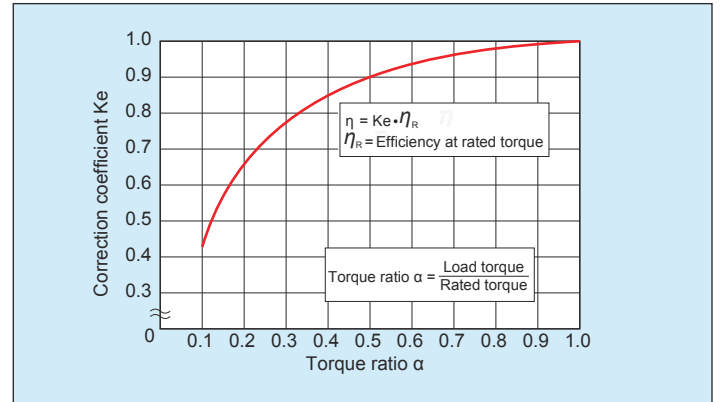

Efficiency at rated torque

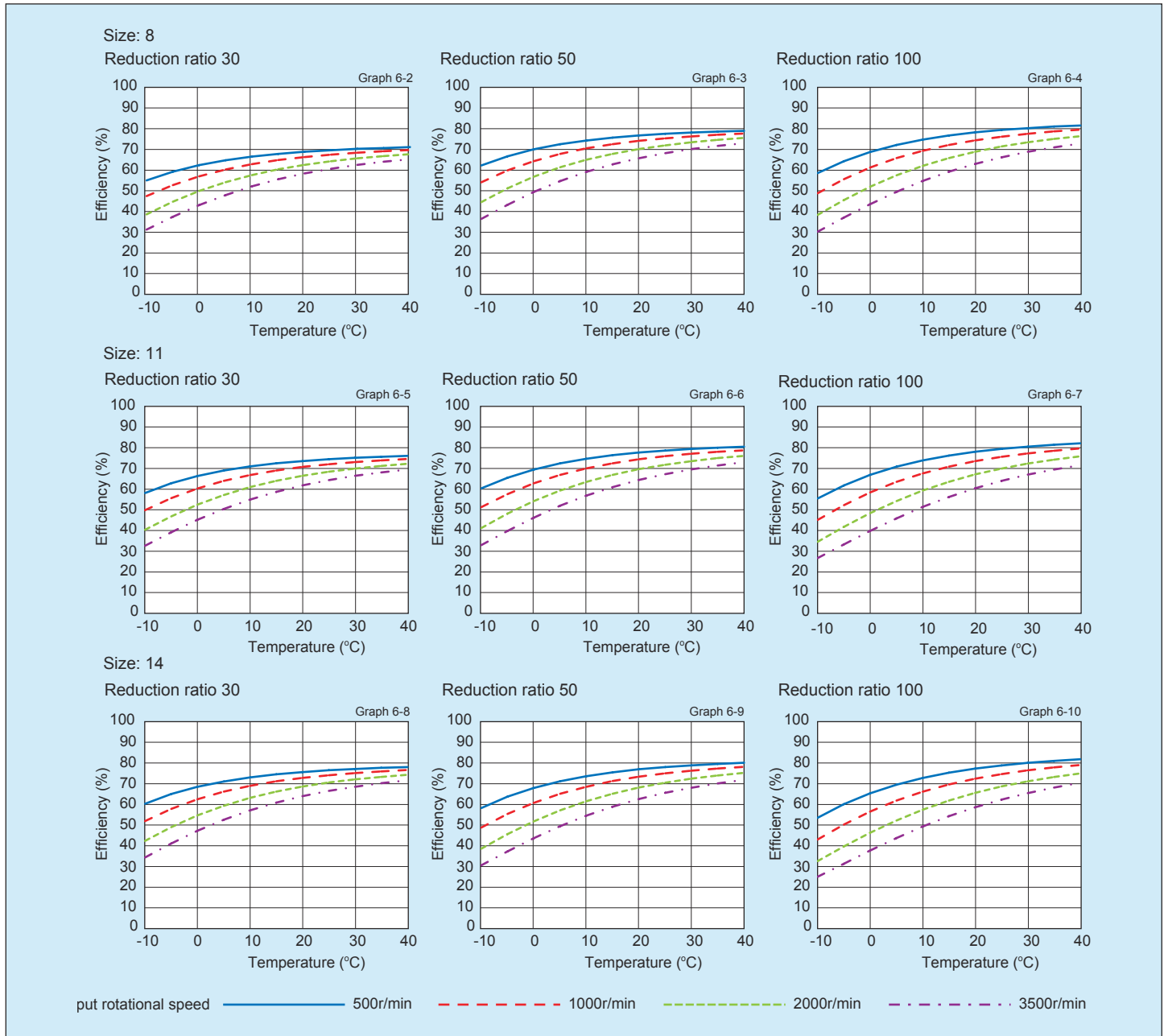

■ No Load Running Torque

No load running torque is the input torque (high-speed shaft side) that is required to rotate a HarmonicDrive® with no load applied to the output.

* For details about the values, please contact our sales representatives.

■ Correction amount by reduction

The no load running torque for HarmonicDrive® varies depending on the reduction ratio. Graphs 7-1 through 7-4 show the value of reduction ratio 100. Other reduction ratios must be calculated by adding the compensation value indicated in Table 7-2.

Measuring condition

Table 7-1

Reduction ratio 100			
Lubrication condition	Grease lubricant	Name	Harmonic Grease® SK-2
The torque value is measured after two or more hours run-in at 2000 r/min input.			

No load running torque compensation value

Table 7-2
Unit: cNm

Size	Reduction ratio	
	30	50
8	0.49	0.22
11	0.81	0.36
14	1.25	0.55

■ No load running torque at reduction ratio 100

Input rotational speed 500r/min

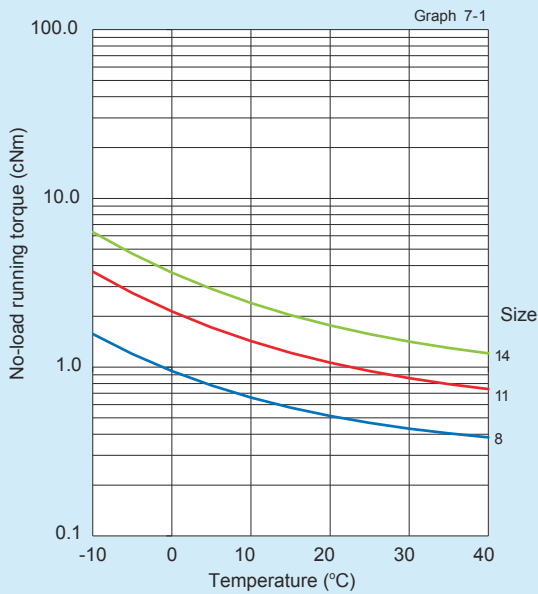

Input rotational speed 1000r/min

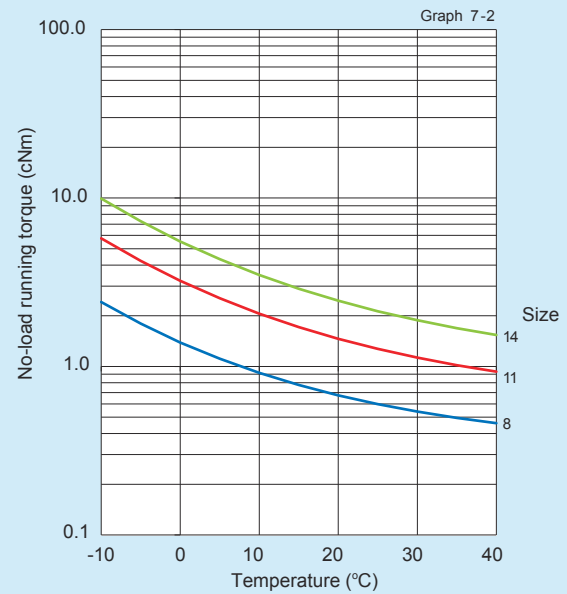

Input rotational speed 2000r/min

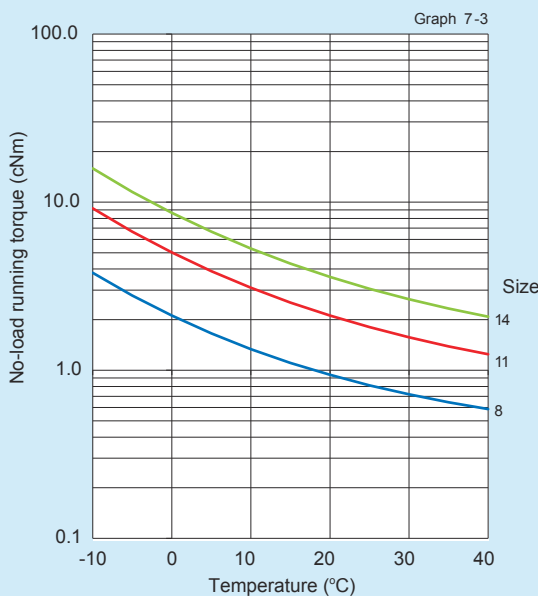

Input rotational speed 3500r/min

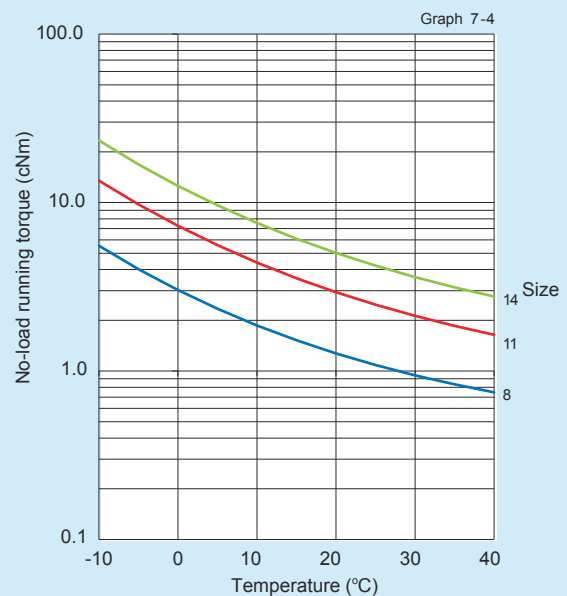

*Average value is \bar{X} in this graph.

■ Example of Mounting

Example of a mounting on the motor is shown below:

Figure 8-1

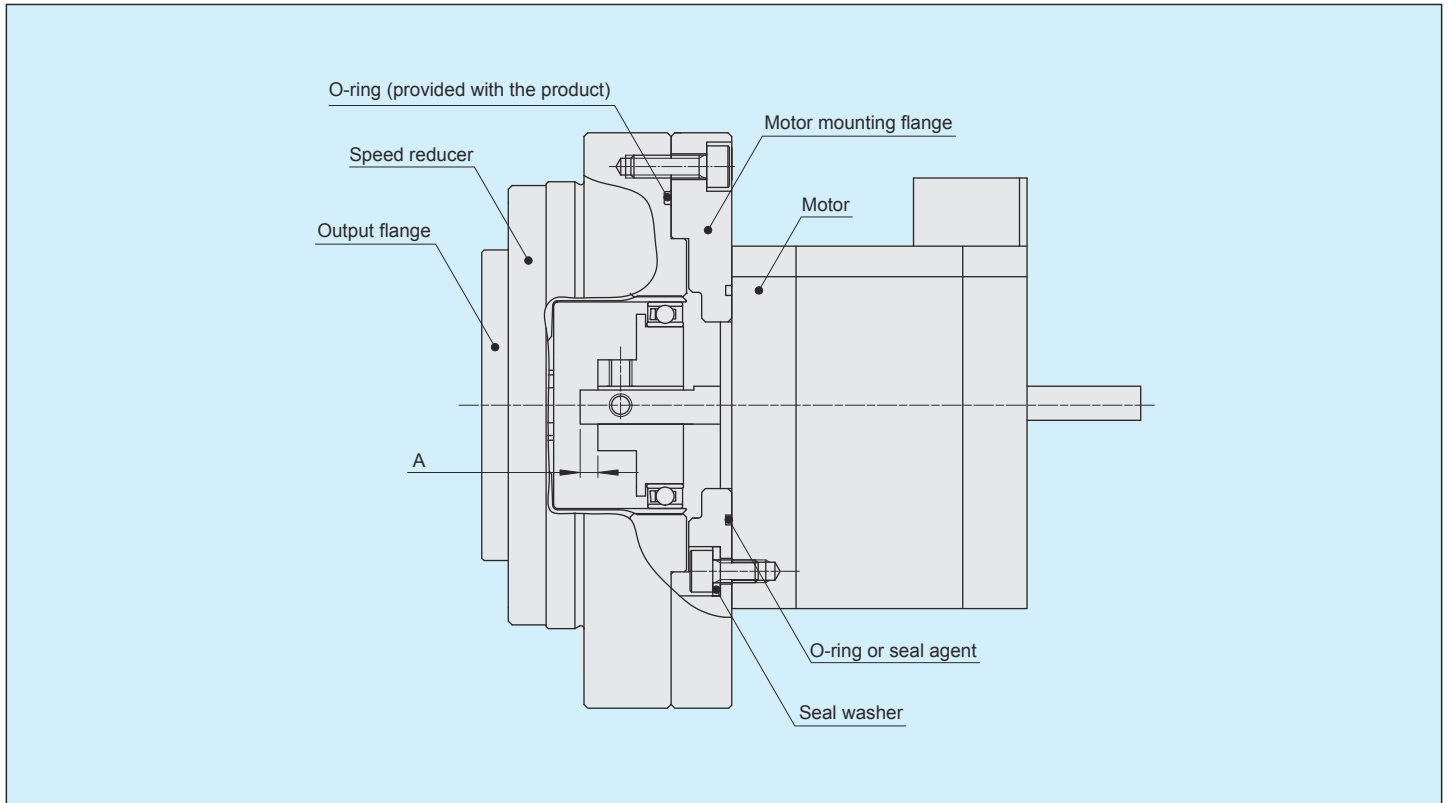

■ Sealing structure

The sealing structure as shown below is required for mounting the motor for the purpose of grease leakage prevention and of maintaining the high durability of HarmonicDrive®.

Table 8-1

Area requiring sealing		Recommended sealing method
Motor mounting flange	On the HarmonicDrive® side (On the reducer side)	Using O-ring (provided with our product)
	On the motor side	O-ring, seal agent, seal washer, and others (Take care regarding the distortion on the plane and how the O-ring is engaged.)
Motor output shaft		Please select a motor output shaft with oil seal attached. If the oil seal is not provided, employ the structure where the oil seal is attached to the motor mounting flange.
Screw hole area		Use the screw lock agent with sealing effect (Loctite 242 is recommended), or use the sealing tape.

* There is no need to apply a seal agent on the output flange because it employs a seal structure.

■ Precautions when installing a motor

Ensure that the motor shaft maximum extrusion amount value A is below the following values:

Table 8-2
Unit: mm

Dimension \ Size	8	11	14
A	2.5	4.5	6

■ Installation Accuracy

In order to fully demonstrate the excellent performance of the CSF-mini series 2UP type in the mounting design, maintain the recommended accuracy as shown below:

Figure 9-1

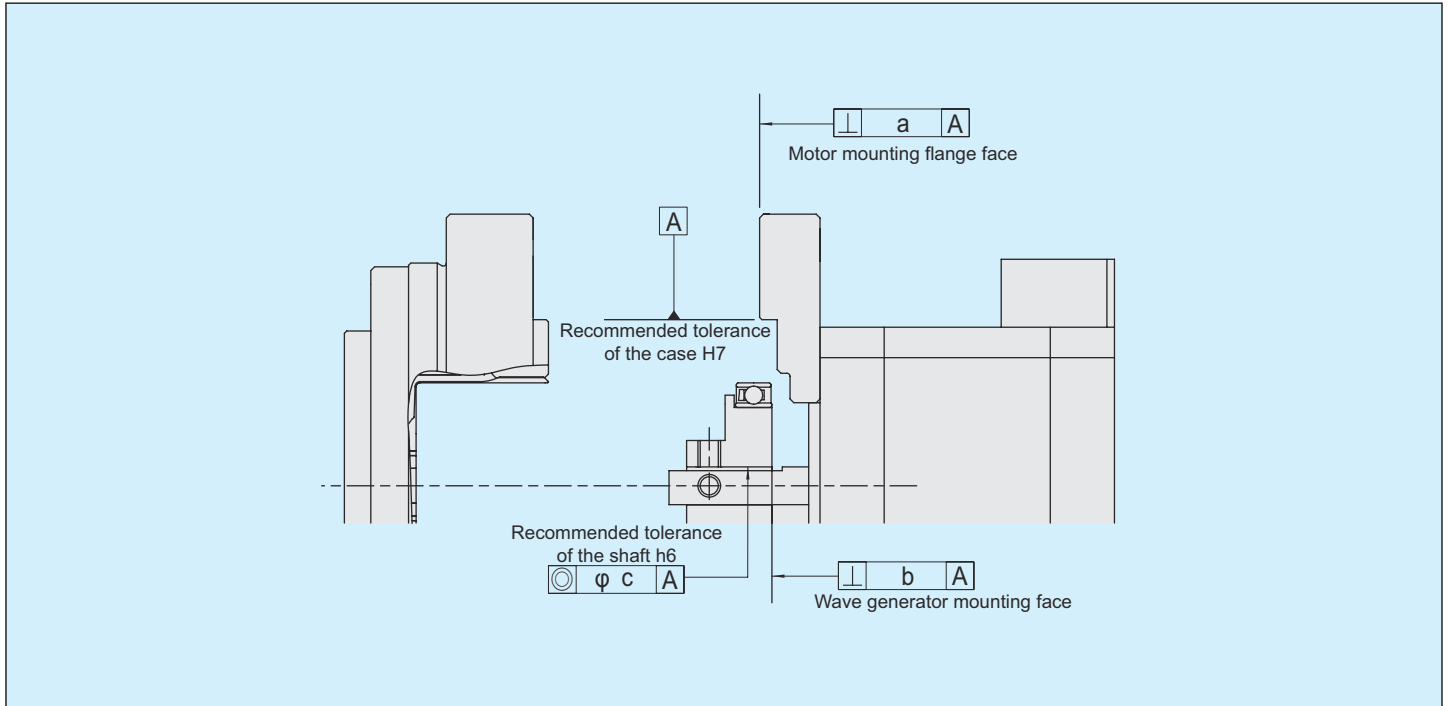
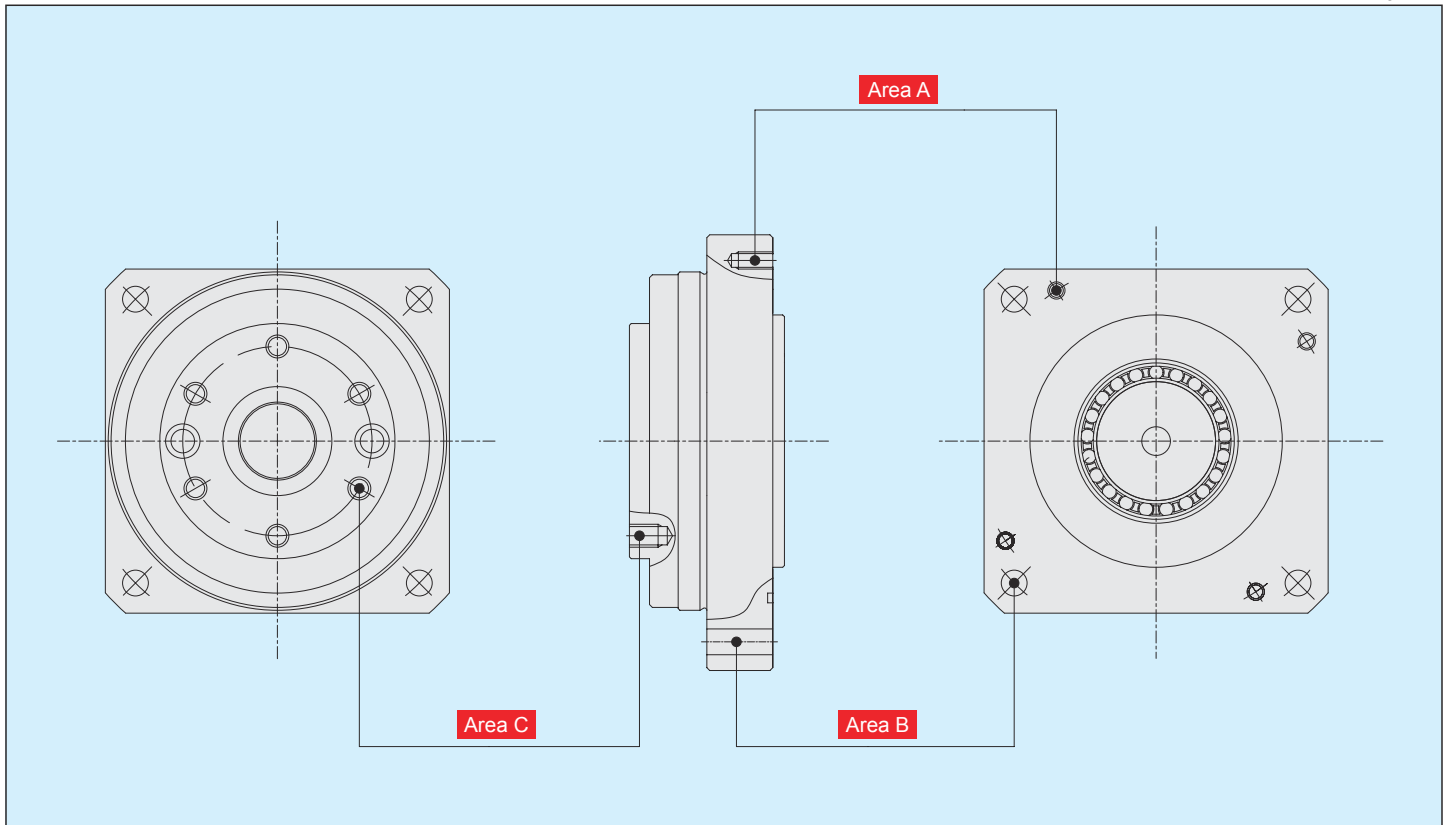

Table 9-1
Unit: mm

Accuracy items	Size	8	11	14
a	Squareness of the case mating face	0.010	0.011	0.011
b	Wave generator mounting face	0.006	0.007	0.008
c	Concentricity of the input shaft	0.006	0.007	0.016

■ Installation and Transmission Torque

Figure 9-2



■ Mounting on the flange **A**

When the CSF-mini series 2UP type is installed on the motor and others, check the flatness of the mounting face and tap part is free from burr and others, then fasten the reducer to the mounting flange etc. by using bolts.

Table 10-1

Item		Size	8	11	14
Number of bolts			4	4	4
Bolt size			M3	M3	M4
Mounting P.C.D	mm		52	63	70.71
Tightening torque*	Nm		0.85	0.85	2.0
	kgfm		0.09	0.09	0.20
Minimum length of the screw mating	mm		3.6	3.6	4.8
Transmission torque*	Nm		18	22	44
	kgfm		1.9	2.3	4.5

* Recommended bolt name: JIS B 1176 hexagon socket head bolt, tensile strength rank: JIS B 1051 12.9 or higher

■ Installation on the equipment **B**

When the CSF-mini series 2UP type is installed on the equipment, check the flatness of the mounting face and tap part is free from burr and others, then fasten the reducer to the mounting flange etc. by using bolts.

Table 10-2

Item		Size	8	11	14
Number of bolts			4	4	4
Bolt size			M3	M4	M5
Mounting P.C.D	mm		58	70	88
Tightening torque*	Nm		1.2	2.7	5.4
	kgfm		0.12	0.28	0.55
Minimum length of the screw mating	mm		3.6	4.8	6.0
Transmission torque*	Nm		29.0	59.1	119
	kgfm		3.0	6.0	1.2

* When the part of the mounting destination is made of steel

* Recommended bolt name: JIS B 1176 hexagon socket head bolt, tensile strength rank: JIS B 1051 12.9 or higher

■ Mounting load on the output side **C**

Perform the work for mounting load on the output side of the CSF-mini series 2UP type by taking into consideration the main roller bearing specifications.

Table 10-3

Item		Size	8	11	14
Number of bolts			6	6	6
Bolt size			M3	M4	M5
Mounting P.C.D	mm		25.5	33.0	44.0
Tightening torque*	Nm		2.0	4.5	9.0
	kgfm		0.20	0.46	0.92
Minimum length of the screw mating	mm		3.6	4.8	6.0
Transmission torque*	Nm		31.9	69.6	184
	kgfm		3.3	7.1	15

There is no need to apply a seal agent to the output flange because it employs a seal structure.

* Recommended bolt name: JIS B 1176 hexagon socket head bolt, tensile strength rank: JIS B 1051 12.9 or higher

■ Motor Mounting Flange

The motor mounting flange is provided by our company.

Please let us know dimensions A through J (when the key groove is attached: A through N) described in Figure 11-1 when ordering because the motor dimension is required for designing.

Figure 11-1

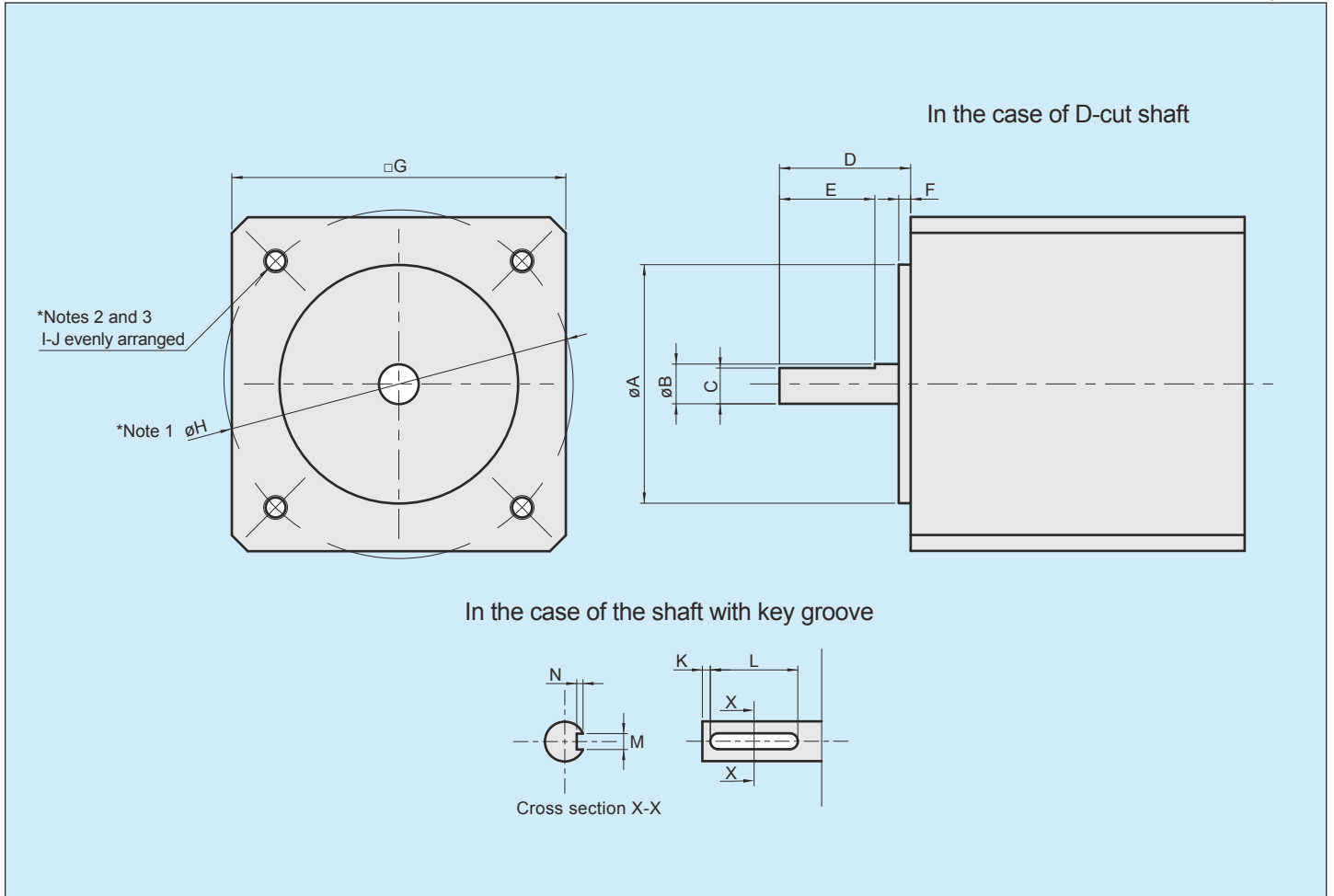

* Note 1. H: Mounting hole pitch diameter or pitch angular dimension

* Note 2. I: Total number of mounting holes

* Note 3. J: Tap hole nominal diameter and hole depth or through hole diameter

* Note 4. Please let us know the O-ring dimension when it is used on the motor and the motor mounting flange connecting part.

* Please contact our sales representative or distributor office for more information.

	Head Office:	Believe Omori 7F, 6-25-3 Minami-Oi, Shinagawa-ku, Tokyo 140-0013 JAPAN Phone: +81-3-5471-7800 / FAX: +81-3-5471-7811
	Hotaka Plant:	1856-1 Hotakamaki, Azumino-shi, Nagano 399-8305 JAPAN Phone: +81-263-83-6800 / FAX: +81-263-83-6901
	Overseas Division:	1856-1 Hotakamaki, Azumino-shi, Nagano 399-8305 JAPAN Phone: +81-263-83-6935 / FAX: +81-263-83-6901
	Taiwan Representative Office:	G219, 11F., No.209, Sec.1, Civic Blvd., Datong Dist., Taipei City, Taiwan (R.O.C.) Phone: +886-2-2181-1640 / FAX: +886-2-2181-1641
	日商哈默納科股份有限公司 台灣代表人辦事處：	台北市大同區市民大道一段209號11樓 G219室 Phone: +886-2-2181-1640 / FAX: +886-2-2181-1641

"HarmonicDrive" is a trademark of Harmonic Drive Systems Inc.
The academic or generic term of our "HarmonicDrive" products is "strain wave gearing."
Harmonic Drive® trademark is registered in Japan, Korea and Taiwan.

HarmonicDrive[®] <small>ハーモニックドライブ</small>	HarmonicPlanetary[®] <small>ハーモニックプラネタリー</small>	HarmonicGrease[®] <small>ハーモニックグリース</small>
HarmonicGearhead[®] <small>ハーモニックギアヘッド</small>	HarmonicLinear[®] <small>ハーモニックリニア</small>	BEAM SERVO[®] <small>ビームサーボ</small>
		Harmonicsyn[®] <small>ハーモニックシン</small>