

HarmonicPlanetary® High Performance Gearheads for Servomotors

GEARHEAD

Short delivery leadtime and low price
Precision Planetary Gearheads HPN series

The HPN series is a very quiet, lightweight, compact design precision planetary gearheads enabling short delivery leadtime. A lineup of HarmonicGearhead® series that is popular in industry-specific machines has been enriched by adding a new HPN series of precision planetary gearheads. We provide a wide variety of high-precision and highly-reliable planetary gearheads with results and trusts in order to respond to the customers by adding the new HPN series.

Application Examples

Gantry robot for machine tools

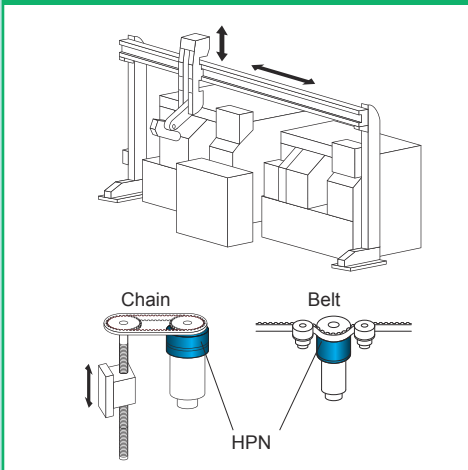

Roller drive

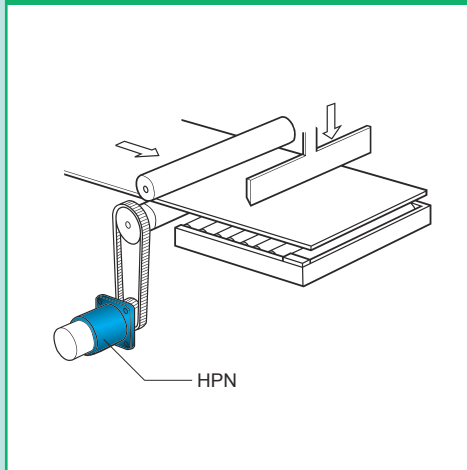

SCARA Robot

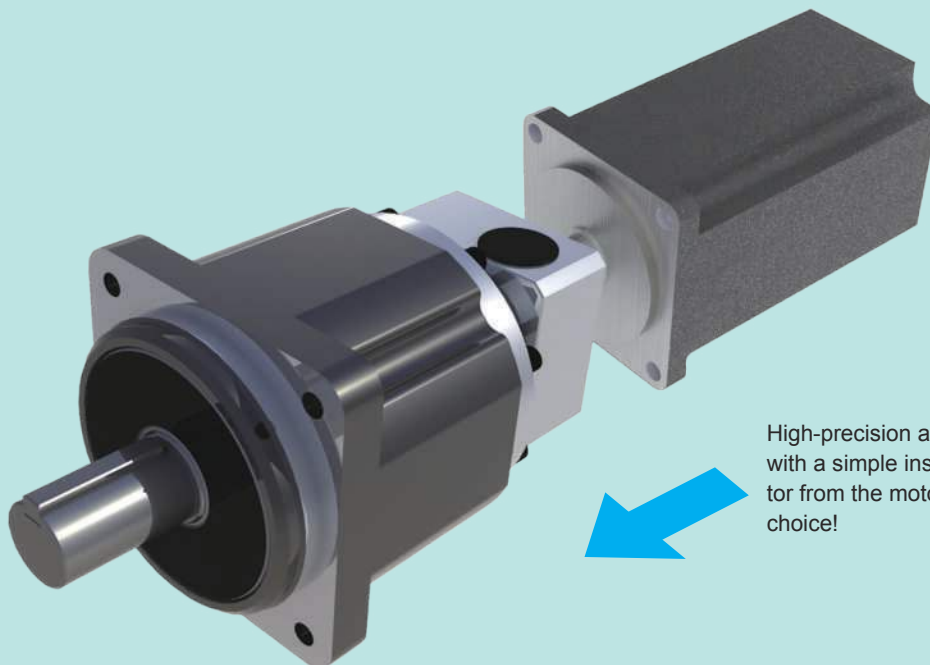
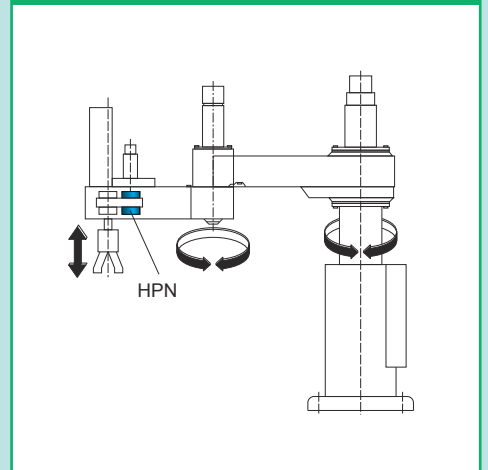

High-precision actuators can be created with a simple installation of a servomotor from the motor manufacturer of your choice!

■ Ordering Code

HPN – **14** **A** – **05** – **J6** **AA-AB1**

Model	Size	Design revision	Reduction ratio	Output shaft shape	Input-side form symbol
HPN High-performance type HarmonicPlanetary®	11	A	4, 5, 7, 10 to 16, 20, and 30	J6: Straight shaft (With key and center tap attached) J8: Straight shaft (Without key and with center tap attached)	This symbol differs depending on the motor to be used.
	14		3, 4, 5, 7, 10, 13, 21, and 31		
	20				
	32				
	40				

* For more information on the compatibility with servo motor and model selection, refer to the following URL.

URL: <http://hds-tech.jp/ecat/ogcte/index.html>



■ Rated Table

Please contact our sales representatives for any question about specifications or about comparison with the products of other gearheads.

Size	Number of stages	Reduction ratio	Rated torque ^{*1}	Repeated peak torque ^{*2}	Momentary peak torque ^{*3}	Rated Input rotational speed ^{*4}	Maximum Input rotational speed ^{*5}
			Nm	Nm	Nm	r/min	r/min
11	1	4	14	14	40	3,000	10,000
		5	14	16	40		
		7	11	11	40		
		10	9	9	40		
	2	16	18	24	40		
		20	22	24	40		
14	1	3	22	25	89	3,000	6,000
		4	28	50	110		
		5	29	50	107		
		7	30	37	100		
	2	10	18	18	79		
		13	30	43	106		
		21	30	50	99		
		31	30	38	101		
20	1	3	51	74	226	3,000	6,000
		4	80	130	256		
		5	80	149	256		
		7	80	113	256		
	2	10	54	54	216		
		13	80	130	256		
		21	80	147	256		
		31	80	113	256		
32	1	3	153	254	625	3,000	6,000
		4	198	376	625		
		5	200	376	625		
		7	200	376	625		
	2	10	185	185	625		
		13	200	376	625		
		21	200	376	625		
		31	200	376	625		
40	1	3	440	752	1,137	3,000	6,000
		4	460	752	1,265		
		5	480	752	1,265		
		7	510	752	829		
	2	10	480	509	829		
		13	530	752	823		
		21	620	752	1,029		
		31	700	752	1,097		

*1: Torque is based on the life of 20,000 hours at rated input speed.

*2: This is the permissible maximum torque applied when acceleration and deceleration during the operation cycle.

*3: This is the instantaneous maximum torque (a maximum of 1,000 times) of impact torque applied in an emergency stop or applied externally. Exceeding this torque could damage the gearhead.

*4: This is the permissible maximum value of the average input rotational speed during the operation. Be careful not to exceed this value especially when the operation is almost continuous.

*5: The max. input rotational speed under the condition of non-continuous operation.

■ Performances

Size	Number of stages	Reduction ratio	Backlash arc min	Noise dB
11	1	4	5 or less	56 or less
		5		
		7		
	2	10	7 or less	
		16		
		20		
14	1	3	5 or less	58 or less
		4		
		5		
	2	7	7 or less	
		10		
		13		
20	1	3	5 or less	60 or less
		4		
		5		
	2	7	7 or less	
		10		
		13		
32	1	3	5 or less	63 or less
		4		
		5		
	2	7	7 or less	
		10		
		13		
40	1	3	5 or less	65 or less
		4		
		5		
	2	7	7 or less	
		10		
		13		
40	1	3	5 or less	65 or less
		4		
		5		
	2	7	7 or less	
		10		
		13		

* The one-third (1/3) of the one stage reduction ratio is excluded from the noise value. For more information, contact us.

■ Efficiency Characteristics

The gearhead efficiency generally differs depending on the gear reduction ratio, input rotational speed, load torque, temperature, and lubrication condition.

The efficiencies of the respective series under the measuring conditions described below are shown in the following and subsequent pages. Note that the average value is shown in this graph.

■ Measurement condition

Input rotational speed	3000 r/min
Ambient temperature	25 °C
Lubricant	Standard lubricant is used. (For more information, refer to the technical document.)

■ Efficiency correction value at low temperature

For the efficient value when the ambient temperature is 25 °C or lower, calculate the value by multiplying the value at 25 °C by efficiency correction value at low temperature.

For the efficiency correction value at low temperature, find the value corresponding to the ambient temperature and rated input torque (TRi*) from the following graph.

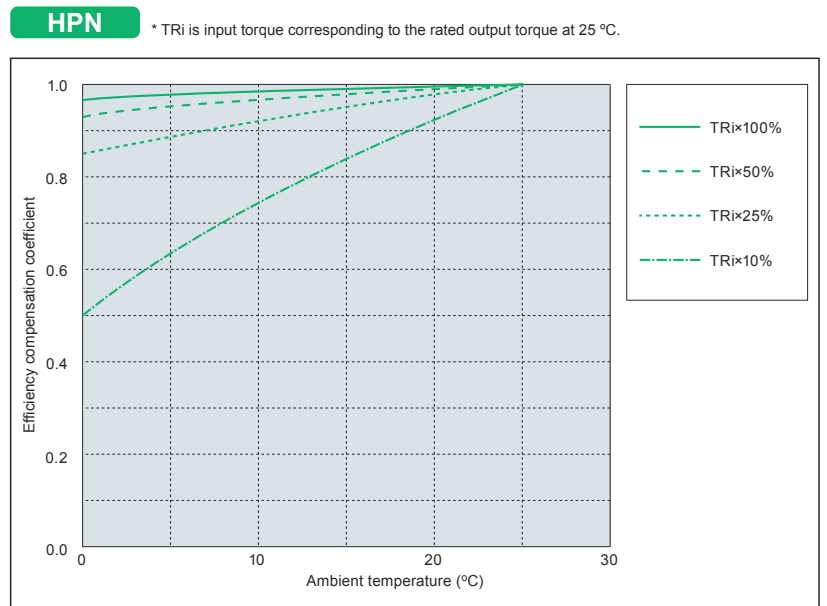

■ Efficiency Characteristics

Size 11A

: Gearhead

HPN

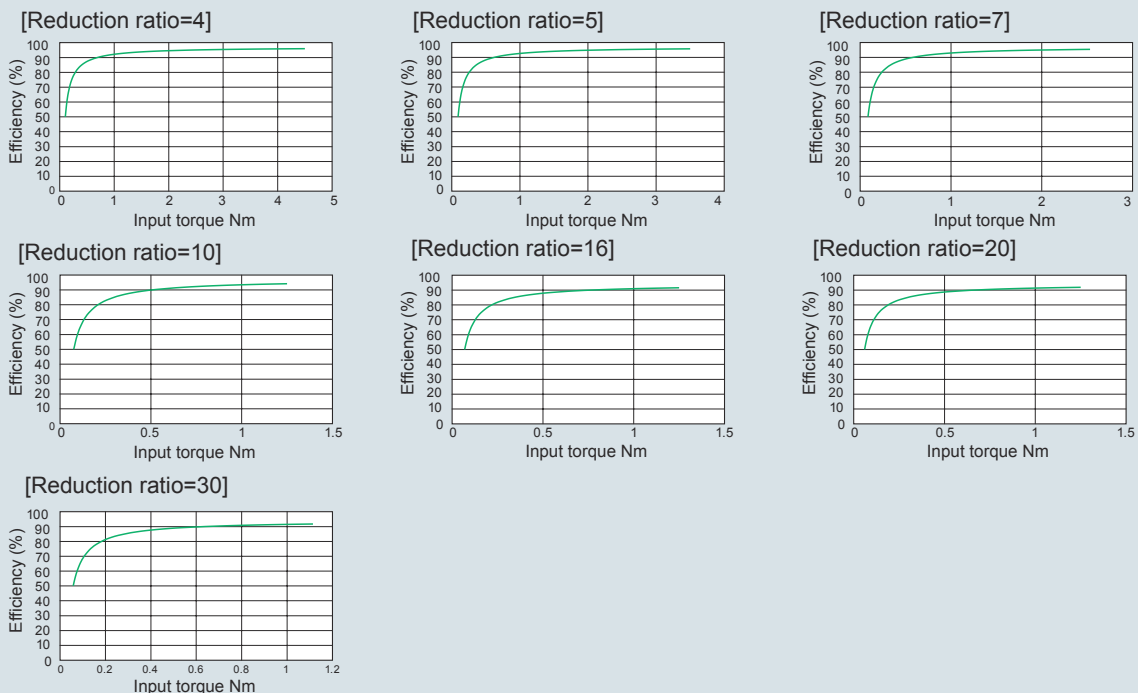

■ Efficiency Characteristics

Size 14A : Gearhead

HPN

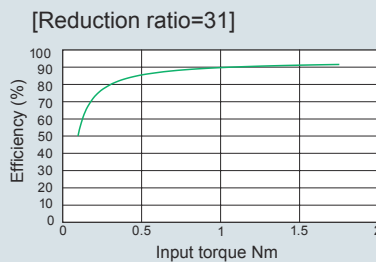
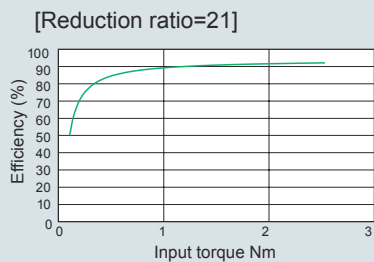
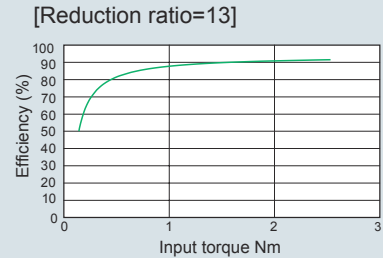
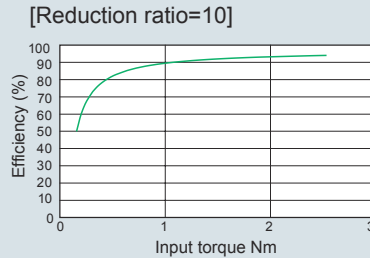
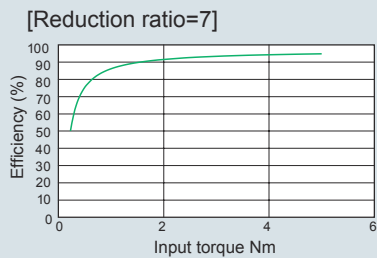
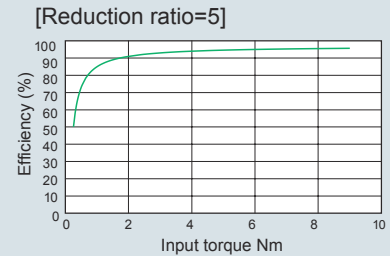
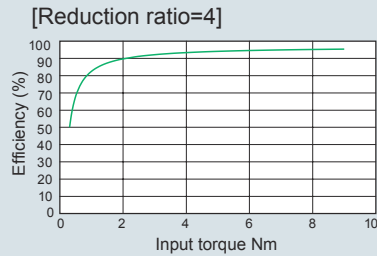
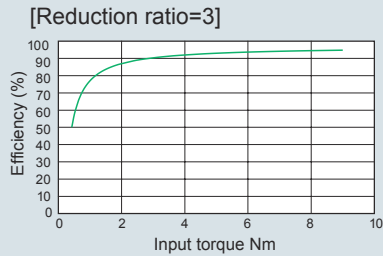

Size 20A : Gearhead

HPN

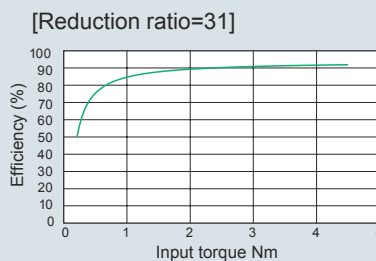
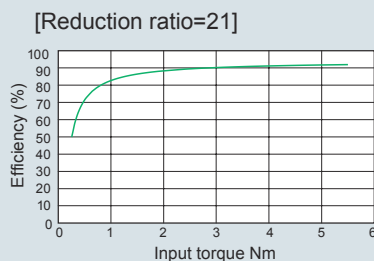
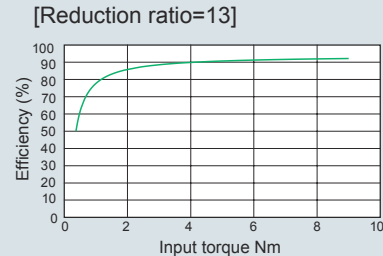
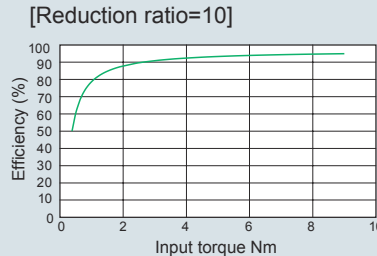
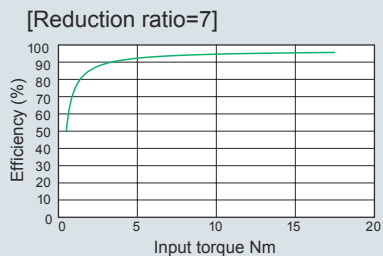
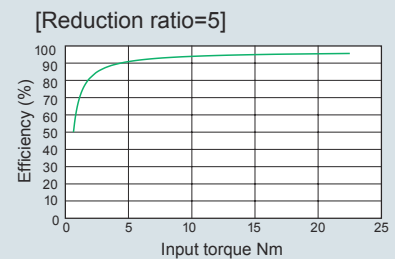
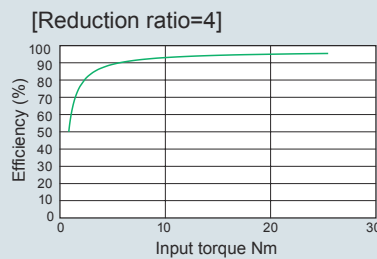
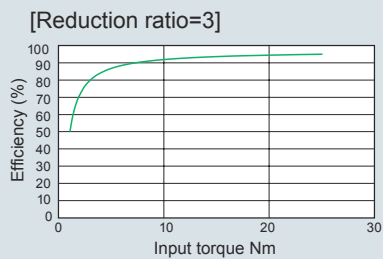

■ Efficiency Characteristics

Size 32A : Gearhead

HPN

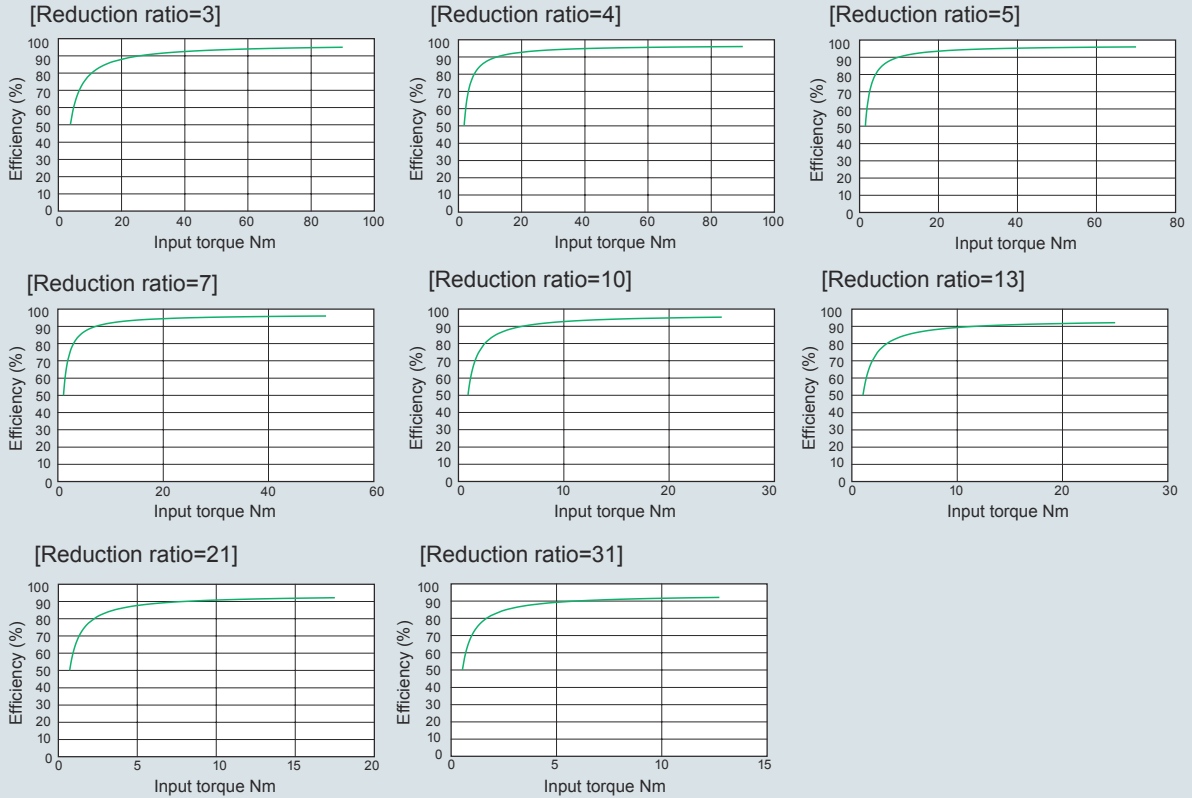

Size 40A : Gearhead

HPN

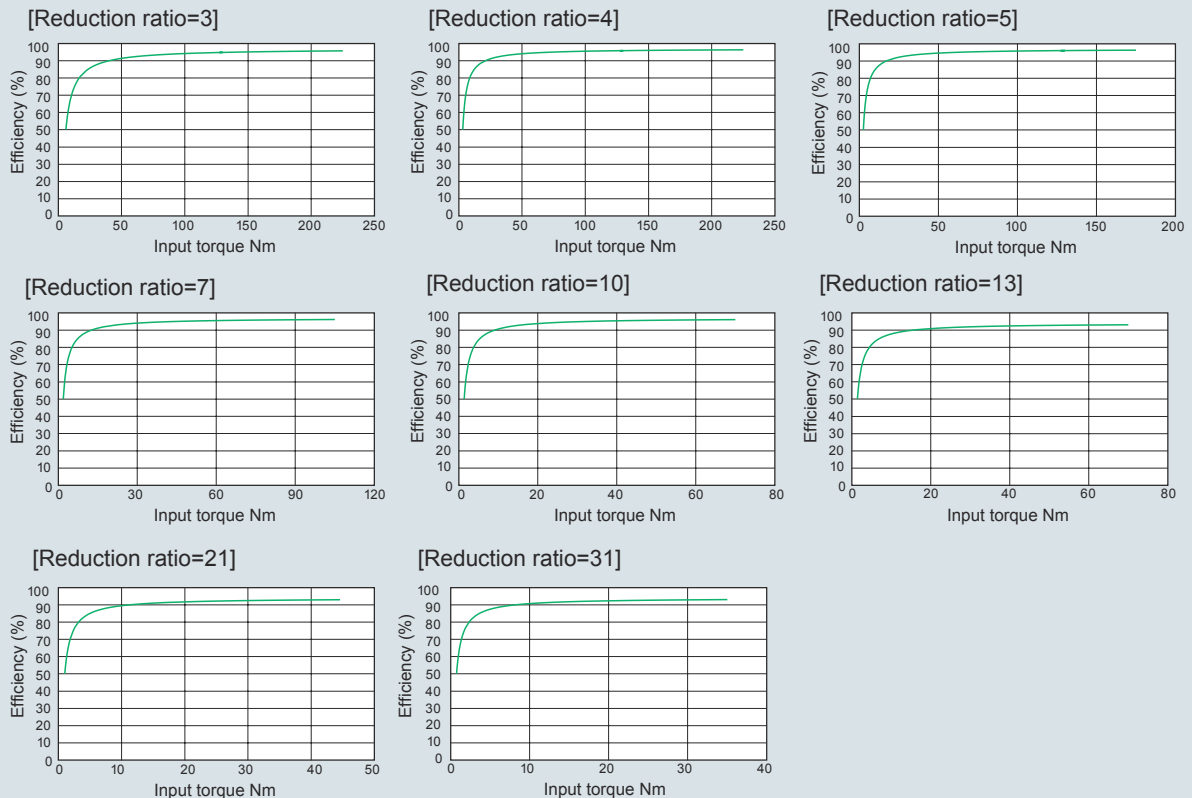

■ Permissible Load of the Output Shaft Bearing

HPN series

The HPN series employs ball bearing for the output shaft bearing.

Use this series within the range of the permissible load value considering the load coefficient f_w based on the operating conditions.

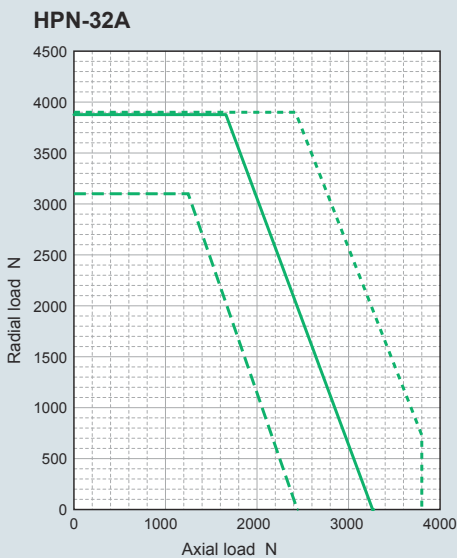
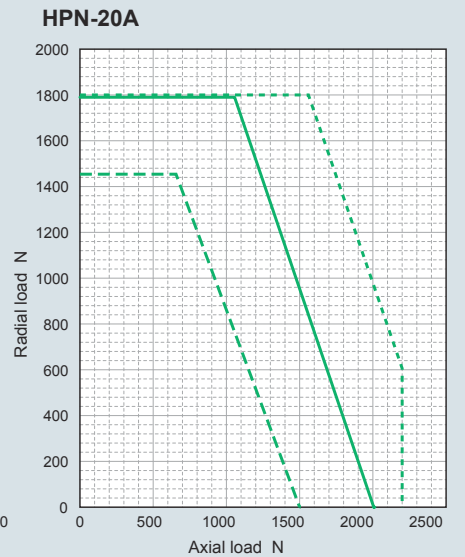
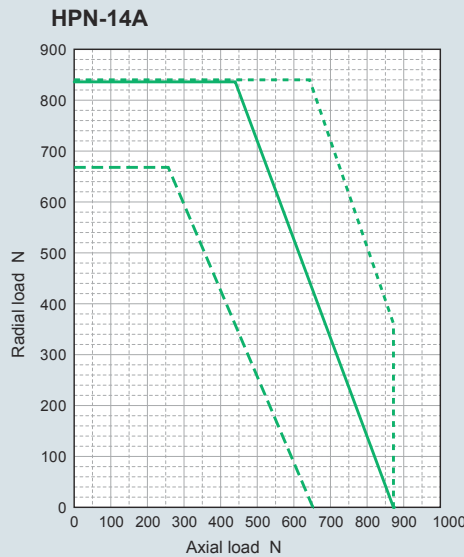
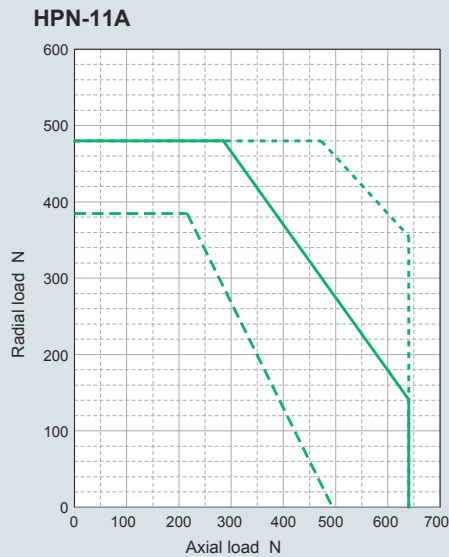

■ Outside Dimensions (Common in Single-stage and Double-stage Types)

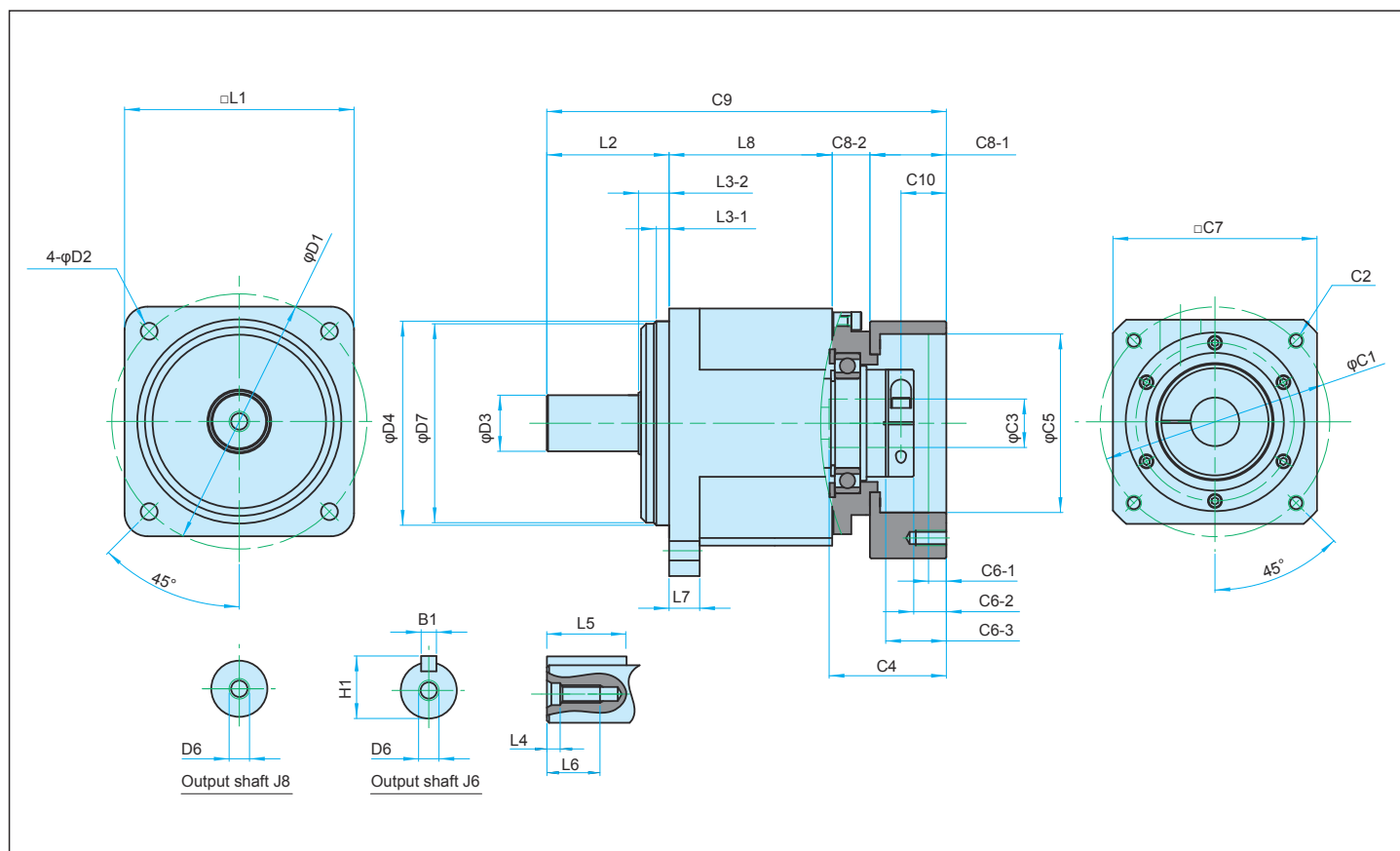

Dimension symbols	HPN-11A	HPN-14A	HPN-20A	HPN-32A	HPN-40A
D1	50	70	100	130	165
D2	3.4	5.5	6.6	9	11
D3	13h7	16h7	22h7	16h7	40h7
D4	35h7	50h7	80h7	110h7	130h7
D6	M4	M5	M8	M12	M16
D7	-	49	78	107	130
L1	42	60	90	115	142
L2	26	37	48	65	97
L3-1	2.5	5	5	5	5
L3-2	6.5	12	12	19	18
L4	3	3.5	4.5	5	6
L5	18	23	32	44	70
L6	12	15	20	26	34
L7	9	8	12	20	35
B1	5h9	5h9	6h9	10h9	12h9
H1	15	18	24.5	35	43
L8, C1 to C10	Varies depending on the reduction ratio and connected motor. Contact us.				

The drawing measurement above shows the values of typical products. For more information other than on the products described above, please contact us.

For more information on the details of dimensions and shapes, refer to the confirmation drawing issued by Harmonic Drive Systems Inc.

* Tolerance differs depending on the part manufacturing method (casting product, machining product).

For more information on the tolerance of a dimension without a tolerance description, please contact us as needed.

■ Handling Instructions

In order to fully demonstrate the excellent performance of the HarmonicGearhead® series, perform the installation and mounting works properly. Observe the recommendations of Harmonic Drive Systems Inc when using the mounting bolt and bolt tightening torque.

■ Procedure for installing to a motor HPN

Follow the procedure below for installing the HPN gearhead to a motor.

- 1 Rotate the input shaft joint in order to align the bolt head to the rubber cap hole.
- 2 Apply sealant on the mounting surface of the gearhead.
(Recommended sealant: Loctite 515)
- 3 Gently insert a motor into the main unit of the gearhead. Stand the gearhead upright as shown in the figure on the right, slide it into the input shaft joint while guiding the motor shaft so as not to fall. Be sure to take appropriate measure, e.g., tightening bolts evenly little by little while avoiding tightening the motor in its inclined position when the gearhead cannot be positioned upright.

- 4 Tighten the motor and the flange part of the gearhead by bolt.

Bolt tightening torque

Bolt size		M2.5	M3	M4	M5	M6	M7	M8	M9
Tightening torque	Nm	0.59	1.4	3.2	6.3	10.7	26.1	51.5	89.9
	kgfm	0.06	0.14	0.32	0.64	1.09	2.66	5.25	9.17

* Recommended bolt: JIS B 1176 hexagon socket head bolt, tensile strength rank: JIS B 1051 12.9 or higher

Caution: Be sure to use the tightening torque listed in the table above when tightening.

- 5 Tighten the bolt of the input shaft joint. (The bolt is provided with the input shaft joint upon delivery. Confirm bolt size with the confirmation drawing issued by Harmonic Drive Systems Inc.

Bolt tightening torque

Bolt size		M3	M4	M5	M6	M8	M10	M12
Tightening torque	Nm	2.0	4.5	9.0	15.3	37.2	73.5	128
	kgfm	0.20	0.46	0.92	1.56	3.8	7.5	13.1

Caution: Be sure to use the tightening torque listed in the table above when tightening. Failure to apply the specified torque may possibly lead to problems, e.g., occurrence of slipping. The bolt size differs depending on the model and motor shaft diameter to be installed.

- 6 The installation procedure is completed when the rubber cap of the accessories is installed.

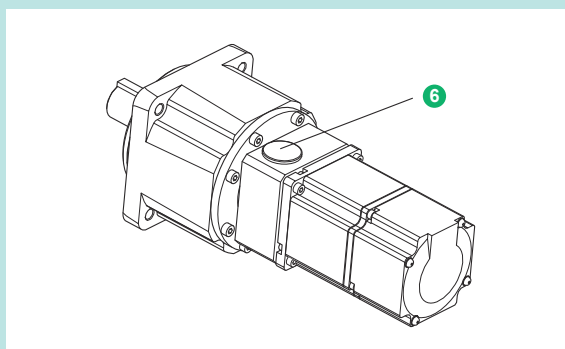
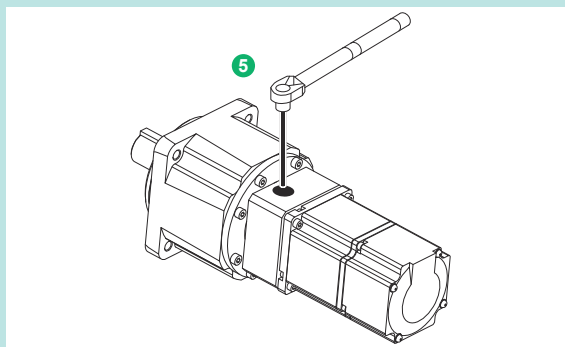
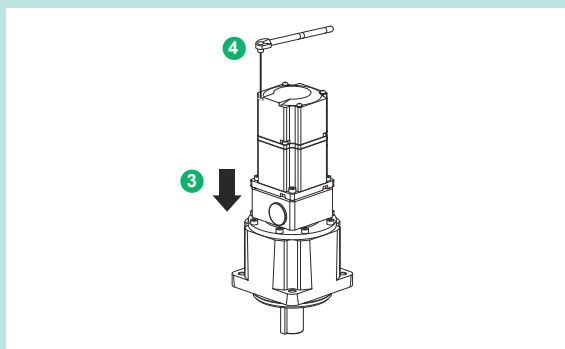
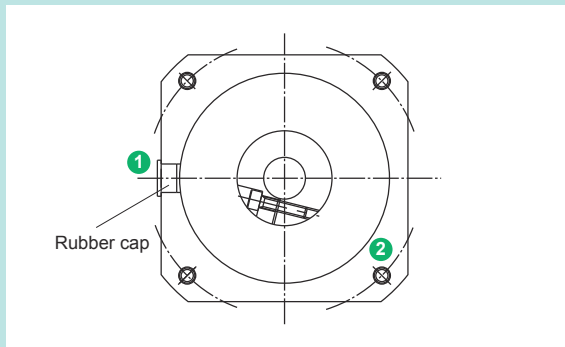

* Please contact our sales representative or distributor office for more information.

	Head Office:	Ichigo Omori Building 7F, 6-25-3 Minami-Oi, Shinagawa-ku, Tokyo 140-0013 JAPAN Phone: +81-3-5471-7800 / FAX: +81-3-5471-7811
	Hotaka Plant:	1856-1 Hotakamaki, Azumino-shi, Nagano 399-8305 JAPAN Phone: +81-263-83-6800 / FAX: +81-263-83-6901
	Overseas Division:	1856-1 Hotakamaki, Azumino-shi, Nagano 399-8305 JAPAN Phone: +81-263-83-6935 / FAX: +81-263-83-6901
	Taiwan Representative Office:	G219, 11F., No.209, Sec.1, Civic Blvd., Datong Dist., Taipei City, Taiwan (R.O.C.) Phone: +886-2-2181-1640 / FAX: +886-2-2181-1641
	日商哈默納科股份有限公司	台北市大同區市民大道一段209號11樓 G219室
	台灣代表人辦事處:	Phone: +886-2-2181-1640 / FAX: +886-2-2181-1641

"HarmonicDrive" is a trademark of Harmonic Drive Systems Inc. The academic or general nomenclature of our products "HarmonicDrive" is "strain wave gearing." The trademark is registered in Japan, Korea and Taiwan.