

HA-655 Series AC Servo Driver Manual

- Thank you very much for your purchasing our HA-655 series servo driver.
- Be sure to use sufficient safety measures when installing and operating the equipment so as to prevent an accident resulting in a serious physical injury damaged by a malfunction or improper operation.
- Product specifications are subject to change without notice for improvement purposes.
- Keep this manual in a convenient location and refer to it whenever necessary in operating or maintaining the units.
- The end user of the driver should have a copy of this manual.



ISO 認証取得



SAFETY GUIDE

For actuators, motors, control units and drivers manufactured by Harmonic Drive Systems Inc



Read this manual thoroughly before designing the application, installation, maintenance or inspection of the actuator.



WARNING Indicates a potentially hazardous situation, which, if not avoided, could result in death or serious personal injury.



CAUTION Indicates a potentially hazardous situation, which, if not avoided, may result in minor or moderate personal injury and/or damage to the equipment.

LIMITATION OF APPLICATIONS:



The equipment listed in this document may not be used for the applications listed below:

- * Space equipment
- * Aircraft, aeronautic equipment
- * Nuclear equipment
- * Household apparatus
- * Vacuum equipment
- * Automobile, automotive parts
- * Amusement equipment, sport equipment, game machines
- * Machine or devices acting directly on the human body
- * Instruments or devices to transport or carry people
- * Apparatus or devices used in special environments





If the above list includes your intending application for our products, please consult us.

Safety measures are essential to prevent accidents resulting in death, injury or damage of the equipment due to malfunction or faulty operation.





CAUTIONS FOR ACTUATORS AT APPLICATION DESIGNING

 <p>CAUTION</p> <p>Always use under followings conditions:</p> <ul style="list-style-type: none"> -Ambient temperature: 0°C to 40°C -Ambient humidity: 20% to 80%RH (Non-condensation) -Vibration: Max 24.5 m/S² -No contamination by water, oil -No corrosive or explosive gas 	 <p>CAUTION</p> <p>Follow exactly the instructions in the relating manuals to install the actuator in the equipment.</p> <ul style="list-style-type: none"> -Ensure exact alignment of motor shaft center and corresponding center in the application. -Failure to observe this caution may lead to vibration, resulting in damage of output elements.
---	--





CAUTION FOR ACTUATORS IN OPERATIONS

 <p>CAUTION</p> <p>Keep limited torques of the actuator.</p> <ul style="list-style-type: none"> -Keep limited torques of the actuator. -Be aware, that if arms attached to output element hits by accident an solid, the output element may be uncontrollable. 	 <p>CAUTION</p> <p>Never connect cables directly to a power supply socket.</p> <ul style="list-style-type: none"> -Each actuator must be operated with a proper driver. -Failure to observe this caution may lead to injury, fire or damage of the actuator.
 <p>CAUTION</p> <p>Do not apply impacts and shocks</p> <ul style="list-style-type: none"> -Do not use a hammer during installation -Failure to observe this caution could damage the encoder and may cause uncontrollable operation. 	 <p>CAUTION</p> <p>Avoid handling of actuators by cables.</p> <ul style="list-style-type: none"> -Failure to observe this caution may damage the wiring, causing uncontrollable or faulty operation.

CAUTIONS FOR DRIVERS AT APPLICATION DESIGNING

 <p>CAUTION</p> <p>Always use drivers under followings conditions:</p> <ul style="list-style-type: none"> -Mount in a vertical position keeping sufficient distance to other devices to let heat generated by the driver radiate freely. -Ambient temperature: 0°C to 50°C -Ambient humidity: less than 95% RH (Non condensation) -No contamination by water, oil or foreign matters -No corrosive, inflammable or explosive gas 	 <p>CAUTION</p> <p>Use sufficient noise suppressing means and safe grounding.</p> <ul style="list-style-type: none"> -Keep signal and power leads separated. -Keep leads as short as possible. -Ground actuator and driver at one single point, minimum ground resistance class: D (less than 100 ohms) -Do not use a power line filter in the motor circuit.
 <p>CAUTION</p> <p>Pay attention to negative torque by inverse load.</p> <ul style="list-style-type: none"> -Inverse load may cause damages of drivers. -Please consult our sales office, if you intent to apply products for inverse load. 	 <p>CAUTION</p> <p>Use a fast-response type ground-fault detector designed for PWM inverters.</p> <ul style="list-style-type: none"> -Do not use a time-delay type ground-fault detector.

CAUTION FOR DRIVERS IN OPERATIONS

 <p>WARNING</p> <p>Never change wiring while power is active.</p> <ul style="list-style-type: none"> -Make sure of power non-active before servicing the products. -Failure to observe this caution may result in electric shock or personal injury. 	 <p>WARNING</p> <p>Do not touch terminals or inspect products at least 5 minutes after turning OFF power.</p> <ul style="list-style-type: none"> -Otherwise residual electric charges may result in electric shock. -Make installation of products not easy to touch their inner electric components.
 <p>CAUTION</p> <p>Do not make a voltage resistance test.</p> <ul style="list-style-type: none"> -Failure to observe this caution may result in damage of the control unit. -Please consult our sales office, if you intent to make a voltage resistance test. 	 <p>CAUTION</p> <p>Do not operate control units by means of power ON/OFF switching.</p> <ul style="list-style-type: none"> -Start/stop operation should be performed via input signals. -Failure to observe this caution may result in deterioration of electronic parts.

DISPOSAL OF AN ACTUATOR, A MOTOR, A CONTROL UNIT AND/OR THEIR PARTS

 <p>CAUTION</p> <p>All products or parts have to be disposed of as industrial waste.</p> <ul style="list-style-type: none"> -Since the case or the box of drivers have a material indication, classify parts and dispose them separately.
--

Contents

Chapter 1	Outlines of the HA-655 driver	1
1-1	Main features	1
1-2	Ordering information	2
1-3	Combinations with actuators	2
1-4	Specifications of HA-655 drivers	3
1-5	External drawing of the HA-655 drivers	4
1-6	Front panel	5
1-7	Outlines of I/O ports	6
1-8	Operating display panel	8
1-8-1	Outlines of operation modes	8
1-8-2	Selecting a mode	8
1-8-3	Functions in modes	9
1-9	Outlines of protective functions	10
1-9-1	Alarms	10
1-9-2	Protective functions	11
Chapter 2	Functions	13
2-1	Control system of the HA-655 driver	13
2-2	Position mode	14
2-2-1	Command configuration in position mode	14
2-2-2	Command transmitting system	16
2-2-3	Outputting encoder signal	16
2-2-4	Absolute encoder signals	17
2-2-5	Tuning servo gains	24
2-2-6	FWD inhibit and REV inhibit	26
2-2-7	In-position	26
2-3	Speed mode	27
2-3-1	Speed conversion factor	27
2-3-2	Voltage of speed command	27
2-3-3	Tuning servo gains	28
2-3-4	Command change	29
2-3-5	Acceleration / deceleration time constants	29
2-3-6	Zero clamp	29
2-4	Other functions	30
2-4-1	Indication of pulse counts	30
2-4-2	Manual JOG operation	30
2-4-3	Monitoring inputs and operating outputs	30

Chapter 3	I/O ports	31
3-1	Position mode	31
3-1-1	I/O port layout	31
3-1-2	Models of I/O port connector CN2	32
3-1-3	I/O port connections in the position mode	33
3-1-4	I/O port functions in the position mode	34
3-1-5	Connection examples in the position mode	41
3-2	Speed mode	45
3-2-1	I/O port layout	45
3-2-2	Models of I/O port connector CN2	46
3-2-3	I/O port connections in the speed mode	47
3-2-4	I/O port functions in the speed mode	48
3-2-5	Connection examples in the speed mode	55
Chapter 4	Installing the HA-655 driver	57
4-1	Receiving Inspection	57
4-2	Notices on handling	58
4-3	Location and installation	59
4-3-1	Environment of location	59
4-3-2	Notices on installation	59
4-3-3	Installing	60
4-4	Suppressing noise	60
4-4-1	Devices for grounding	60
4-4-2	Installing noise filters	61
4-4-3	Instructions for cabling	62
4-5	Connecting power cables	63
4-5-1	Instructions for power supply	63
4-5-2	Power cable and ground cable	63
4-5-3	Connecting power cables	64
4-5-4	Isolation transformer	64
4-5-5	Protecting power lines	65
4-6	Connecting a ground wire	65
4-7	Connecting motor and regeneration resistor cables	65
4-8	Connecting cables for the encoder and the I/O	66
4-8-1	Preparing the encoder cable and the I/O cable	66
4-8-2	Pin layouts of encoder connector (CN1)	66
4-8-3	Pin layouts of the I/O signal connector (CN2)	67
4-8-4	Connecting cables for the encoder and I/O signals	67
4-9	Power ON and OFF sequences	68

Chapter 5	Operations	70
5-1	Test run	70
5-1-1	Driving an actuator without load	70
5-1-2	Setting parameters	74
5-1-3	Tuning servo parameters	76
5-1-4	End of test run	77
5-2	Usual operation	78
5-2-1	Notices for daily operations	78
5-2-2	Daily maintenance	78
Chapter 6	Operation of the display panel	79
6-1	Summary of modes	79
6-2	Selecting a mode	79
6-3	Functions of modes	80
6-4	Monitor mode	81
6-4-1	Operating in the monitor mode	81
6-4-2	Functions of the monitor mode	82
6-5	Tune mode	92
6-5-1	Operating in the tune mode	92
6-5-2	Functions of the tune mode	94
6-6	Parameter mode	102
6-6-1	Operating in the parameter mode	102
6-6-2	Functions of the parameter mode	104
6-7	Test mode	113
6-7-1	Operating in the test mode	113
6-7-2	Functions of the test mode	115
6-8	Defaults of parameters	121
Chapter 7	Troubleshooting	122
7-1	Alarms and diagnostic tips	122
7-2	Troubleshooting for improper actuator motions	133
7-2-1	Improper motions in position mode	133
7-2-2	Improper motions in speed mode	137
Chapter 8	Options	141
8-1	Extension cables	141
8-2	Connectors	141
8-3	Software for setting up parameters	142
8-4	Backup battery for absolute encoders	142
8-5	Isolation transformer	143
Index		Index 1

Chapter 1 Outlines of HA-655 driver

The HA-655 series are dedicated servo drivers for FHA-C series actuators, which are axially compact and feature a large through-hole. The actuators utilize Harmonic drive® gear components for precise motion control and super flat AC servomotors.

The HA-655 drivers provide many superior functions to allow the FHA-C actuators to excel in performance.

1-1 Main features

◆ Easy parameter setting

Parameters have been set to match the driver with the FHA-C series actuator you have ordered. No setting for the actuator is necessary by users.

The HA-655 series provides four modes that can be adjusted by end users: monitor mode, tune mode, parameter mode, and test mode. Parameters of these modes are indicated on a front panel of the driver using a 7-segment LED display and are easily set.

◆ Substantial monitoring functions

The monitor mode indicates various operational parameters and makes it possible to indicate the required parameters for the servo system; such as commands, feedback, or an error counter.

Up to eight previous alarms are also indicated as alarm history that is helpful for diagnosis.

◆ Individual control power supply

It is possible to troubleshoot safely because the control power supply is individuated from the main.

◆ Easy test operation

The test mode helps testing a servo system by JOG operation with keys on the front panel.

Monitoring and operating I/O ports with the keys also help checking command sequences of a host without actuator motions.

◆ Complex encoder cable

Improvement of data transmission with an encoder saves its wires resulted in increased reliability and simplified wiring.

◆ Optional absolute encoder

The optional encoder system surely keeps its current position all the time, even in power failure.

◆ Electronic gear suitable for mechanical system

The electronic gear function adjusts commands to a feed pitch of a driven mechanism such as gears or lead screws.

◆ Three types of input signals for position commands

Three types of input signals for the position command are selectable: two-pulse train (Forward Pulse, Reverse Pulse), single-pulse train (Step and Direction), and two phase pulse train (Quadrature Input Signals).

1-2 Ordering information

◆ HA-655 driver:

HA-655-2 A-200

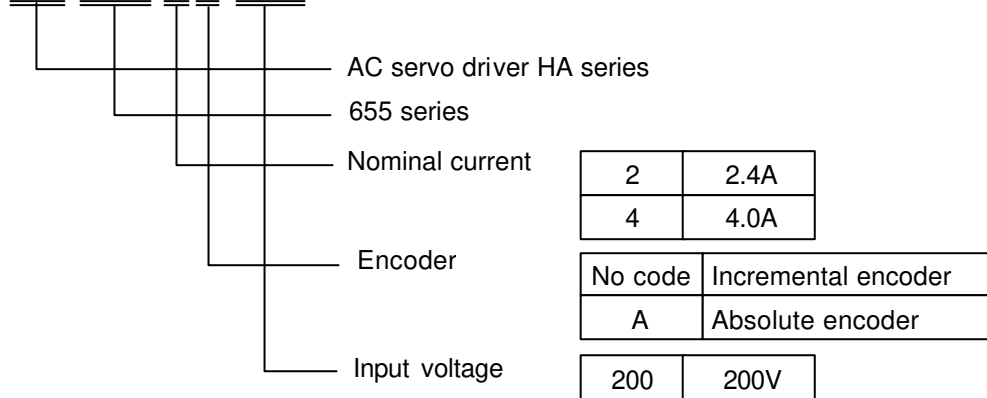

◆ Extension cables (optional):

for a motor: EWC - MB ** -M08 - TN

for an incremental encoder: EWC - E ** -B04 - 3M14

for an absolute encoder: EWC - S ** -B08 - 3M14

Cable length

03	3m
05	5m
10	10m

◆ Connectors (optional):

CNK-HA65-S 1

◆ Software for setting up parameters (optional):

PSF-650

◆ Backup battery for absolute encoder (optional):

HAB-ER17/33

◆ Isolation transformer (optional):

PT1 - 200 04 - 200

Ins. transformer: PT1 series

2nd volt.

200	AC 200V
-----	---------

2nd cur.

04	4A
08	8A

Prim. Volt.

100	AC100V
115	AC115V
200	AC200V
220	AC220V

1-3 Combinations with actuators

Two HA-655 models are available for use with FHA-C actuators dealing with their nominal current. The correct combinations are as follows:

Driver model	Actuator model
HA-655-2-200	FHA -17C
	FHA -25C
HA-655-4-200	FHA -32C
	FHA -40C

Note: Above combinations are valid for 200V power supply only.

1-4 Specifications of HA-655 drivers

Item		Model	HA-655-2-200	HA-655-4-200
Applicable actuator			FHA-17C / FHA-25C	FHA-32C / FHA-40C
Driver's nominal current			2.4 A	4.0 A
Driver's maximum current			7.3 A	18.0 A
Power voltage	Main circuit		AC200 to 240V(1 / 3-phase) +10 to -15% 50/60Hz	
	Control circuit		AC 100 to 115V(1-phase) or AC200 to 240V(1-phase) +10 to -15% 50/60Hz	
Power Control Method			Sinusoidal PWM control	
Allowed Environment			Operating temperature: 0 to 50°C Storage temperature:-20 to 85°C Operating/storage humidity: below 95%RH (No condensation) Vibration resistance: 4.9 m/s ² (10 to 55Hz) Impact resistance: 98m/s ²	
Ventilation			Self cooling	
Installation			Base mount (Wall mount)	
Applicable feedback encoder			Incremental or absolute encoder	
Encoder interface			Serial transmission line driver input type	
Control mode			Position mode, speed mode	
Speed mode	Command voltage		DC± 10V / maximum speed Input impedance: approx. 68kΩ	
	Input signal		Servo-ON, Alarm clear, FWD-enable, REV-enable, Command alternation, *Absolute date request, *Absolute multi-turn data clear (Insulated by opt-isolators)	
	Output signal		Attained speed, Alarm, Alarm code (4-bit) (Insulated by opt-isolators)	
	Speed control range		1:1000 or more	
	Speed regulation		By load Below ± 0.05% at nominal speed by load change from zero to maximum torque By voltage Below ± 0.05% at nominal speed by voltage change in its allowance By temperature Below ± 0.2% at nominal speed by temperature change from 0°C to 50°C	
Position mode	Command pulse interface		Line driver(compliant with EIA422A standard), open collector	
	Command configuration		1-pulse train (step and direction), 2-pulse train (FWD/REV pulses), 2-phase pulse (A-B phase pulses with 90 degree difference)	
	Command frequency		Line driver: 500kpps(max) Open collector: 200kpps(max) , limited by actuator's maximum speed	
	Input signal		Servo-ON, Error counter- alarm clear, FWD inhibit, REV inhibit, *Absolute date request, *Absolute multi-turn data clear (Insulated by opt-isolators)	
	Output signal		In-position, alarm, ready, alarm code (4-bit) (Insulated by opt-isolators)	
Position signal output			Phase-A, -B, -Z; line driver output; Phase-Z: Photo-coupler output	
Analog monitor			2ch: motor speed, current command	
Front panel	Configuration		Display: 7-segment LED 6 digits (red) Operation key: 4 keys	
	Monitor function		Motor speed (r/min), torque (%), over load rate (%) Input signal monitor, output signal monitor, alarm history (up to 8 alarms)	
	Parameters		System parameters Tune parameters	
Protection function			Over current, overload, error counter overflow, over speed, abnormal regeneration Encoder failure, communication error, CPU failure, memory failure, *multi-turn data error, *encoder system failure, *encoder overflow, *battery low voltage, *absolute data transmitting rule error	
Regeneration			Built-in regeneration resistor: absorbable power: 40W (maximum) External regeneration resistor is acceptable.	
Functions			Monitoring, self diagnosis, electronic gear, JOG operation, trapezoidal speed profile, and etc. *backup battery for multi-turn data	
Rush current suppressing circuit			Built-in	
Operation mode			Monitor mode (usual operations), test mode, tune mode, Parameter mode	
Mass			1.5 kg	1.7 kg

Note: the specifications marked with (*) are valid for absolute encoders only.

1-5 External drawing of the HA-655 drivers

The external drawing is shown as follows:

Unit : mm (Third angle projection method)

<External Dimensions>

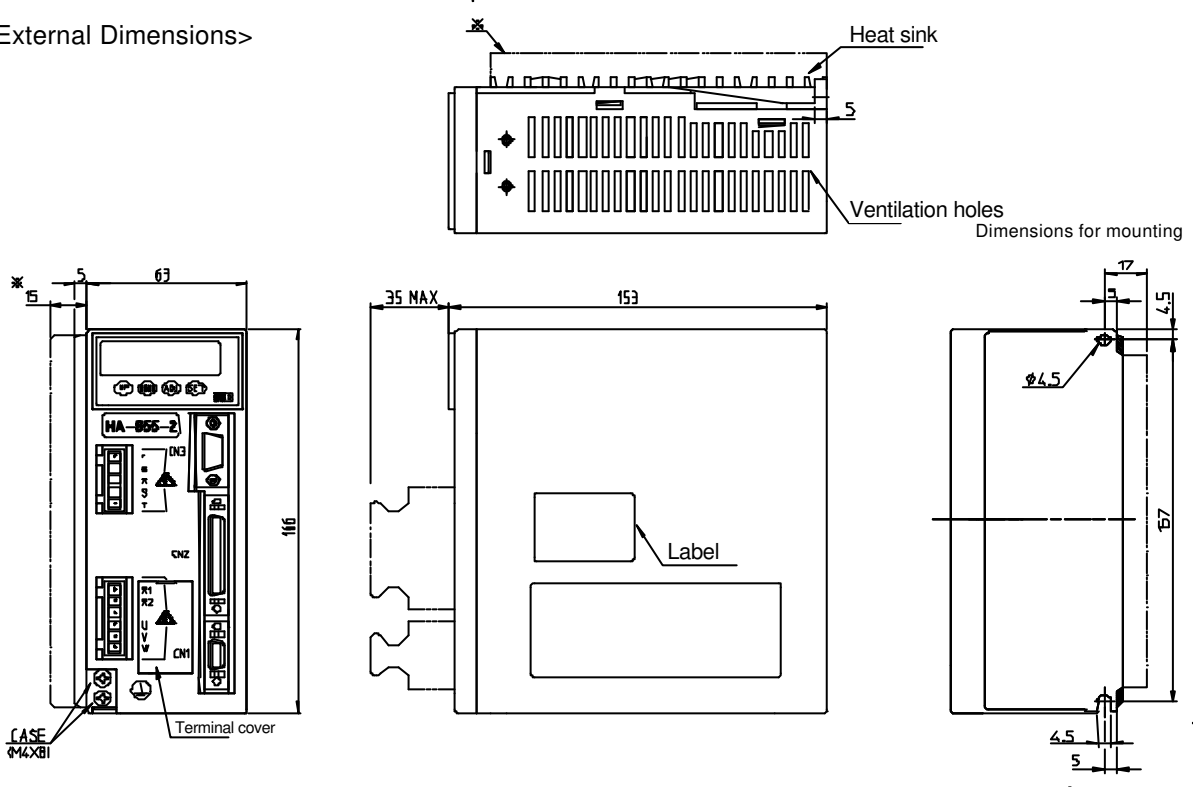

Note 1: When HA-655 drivers are installed in a cabinet, leave enough ventilation space for cooling as shown below.

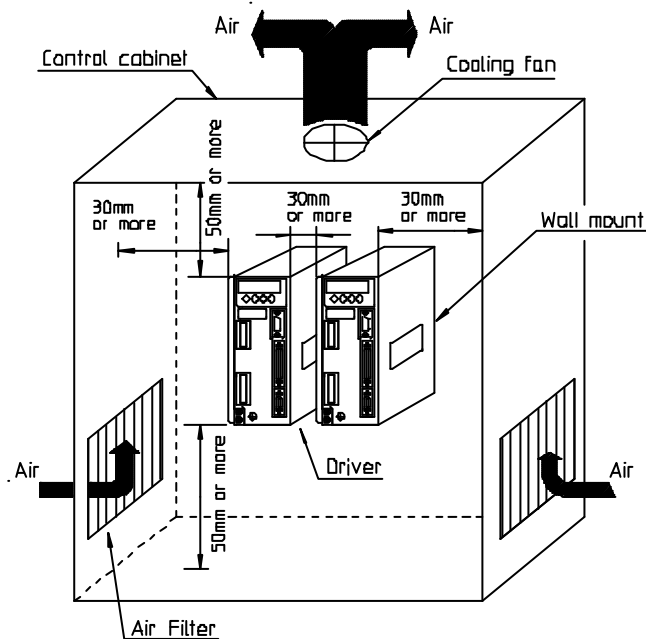

1-6 Front panel

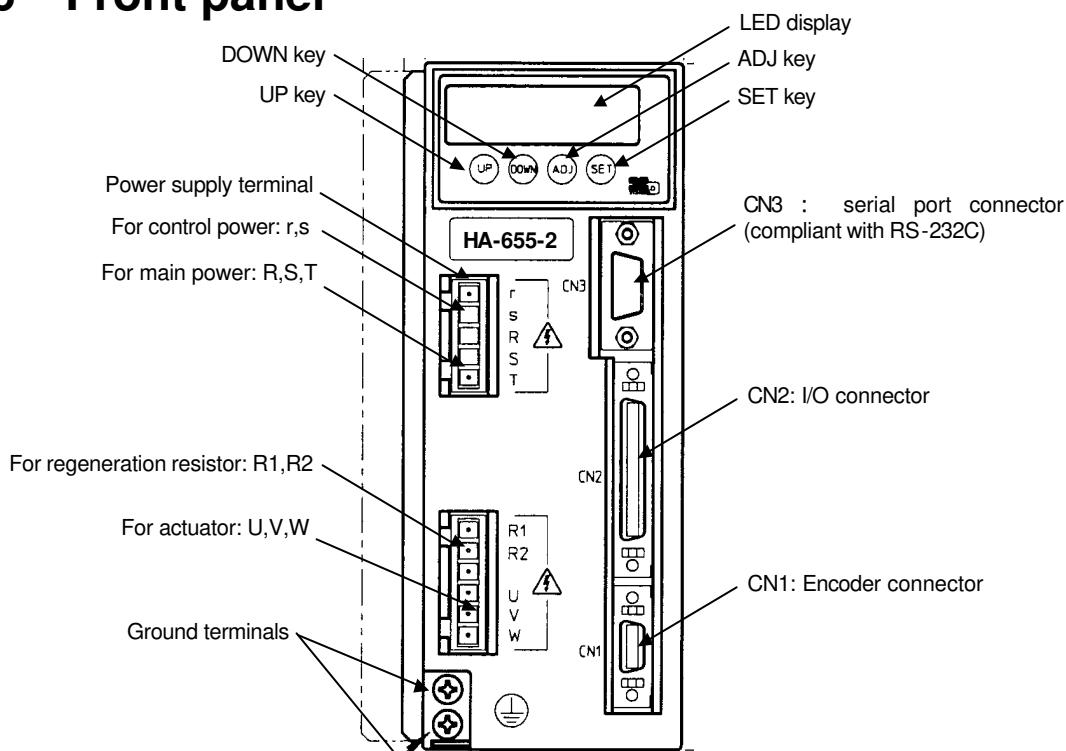

Functions

- ◆ **LED display**

Indicates operating states of the HA-655 driver, parameters, alarms, by a 6-digit 7segment-LED.

- ◆ **Keys labeled [UP], [DOWN], [ADJ], and [SET]**

Are used for changing indications, setting and tuning functional parameters, and operating an actuator manually in a JOG mode.

- ◆ **CN1: encoder connector**

Accepts a connector of an encoder cable form an actuator.

- ◆ **CN2: I/O connector**

Accepts I/O signals to/from a host device.

- ◆ **CN3: Serial port connector (compliant with RS-232C)**

Is connected to a PC with a dedicated cable. You can monitor, set, and tune parameters on the PC's display. (Notice: Optional software is available.)

- ◆ **Power supply terminals: r, s, R, S, T**

Are provided for connecting the power supply. Control power is supplied to the [r, s] terminals, and main power is supplied to the [R,S,T] terminals. (single Phase: R,S; or three phase: R,S,T).

- ◆ **External regeneration resistor terminals: R1, R2**

If the built-in regeneration resistor is insufficient in its capacity to handle frequent start/stop operations of an actuator, an external resistor can be connected to these terminals.

- ◆ **Actuator terminals: U, V, W**

Accept an actuator cable. Connect each motor wire to the driver's terminal marked with a same symbol. If you confuse the symbols, the driver and the actuator may be in failure.

- ◆ **Ground terminals (Protective earth)**

Connect grounds here to prevent electrical shock.

1-7 Outlines of I/O ports

The CN2 connector provides input and output signals to and from a host device. The 50 pins of the connector are assigned to the following signals in each of the [position mode] and the [speed mode]. (Notice: Do not connect signals to pins marked “-“.)

<<For incremental encoder system>>

Position mode

Pin	Signal	Symbol	I/O
1	Input signal common	IN-COM	Input
2	Clear	CLEAR	Input
3	Servo-ON	S-ON	Input
4	FWD inhibit	FWD-IH	Input
5	REV inhibit	REV- IH	Input
6	-	-	-
7	-	-	-
8	Input signal common	IN-COM	Input
9	-	-	-
10	-	-	-
11	-	-	-
12	-	-	-
13	-	-	-
14	-	-	-
15	-	-	-
16	-	-	-
17	-	-	-
18	-	-	-
19	-	-	-
20	-	-	-
21	-	-	-
22	-	-	-
23	Speed monitor	SPD-MON	Output
24	Current monitor	CUR- MON	Output
25	Monitor ground	GND	Output
26	+24V	+24V	Input
27	FWD pulse+	FWD+	Input
28	FWD pulse-	FWD-	Input
29	REV pulse+	REV+	Input
30	REV pulse-	REV-	Input
31	-	-	-
32	-	-	-
33	In-position	IN-POS	Output
34	Alarm	ALARM	Output
35	-	-	-
36	-	-	-
37	Ready	READY	Output
38	Alarm-A+	ALM-A	Output
39	Alarm-B+	ALM-B	Output
40	Alarm-C+	ALM-C	Output
41	Alarm-D+	ALM-D	Output
42	Phase-Z (OC)	Z	Output
43	Output common	OUT-COM	Output
44	Phase-A+ (LD)	A+	Output
45	Phase-A- (LD)	A-	Output
46	Phase-B+ (LD)	B+	Output
47	Phase-B- (LD)	B-	Output
48	Phase-Z+ (LD)	Z+	Output
49	Phase-Z- (LD)	Z-	Output
50	Frame ground	FG	Output

Speed mode

Pin	Signal	Symbol	I/O
1	Input signal common	IN-COM	Input
2	Clear	CLEAR	Input
3	Servo-ON	S-ON	Input
4	FWD enable	FWD-EN	Input
5	REV enable	REV-EN	Input
6	Command change	CMD-CHG	Input
7	-	-	-
8	Input signal common	IN-COM	Input
9	-	-	-
10	-	-	-
11	-	-	-
12	-	-	-
13	-	-	-
14	-	-	-
15	-	-	-
16	-	-	-
17	-	-	-
18	-	-	-
19	-	-	-
20	-	-	-
21	-	-	-
22	-	-	-
23	Speed monitor	SPD-MON	Output
24	Current monitor	CUR- MON	Output
25	Monitor ground	GND	Output
26	-	-	-
27	-	-	-
28	-	-	-
29	-	-	-
30	-	-	-
31	Speed command	SPD-CMD	Input
32	Speed command ground	SG-GND	Input
33	Attained speed	HI-SPD	Output
34	Alarm	ALARM	Output
35	-	-	-
36	-	-	-
37	Ready	READY	Output
38	Alarm-A+	ALM-A	Output
39	Alarm-B+	ALM-B	Output
40	Alarm-C+	ALM-C	Output
41	Alarm-D+	ALM-D	Output
42	Phase-Z (OC)	Z	Output
43	Output common	OUT-COM	Output
44	Phase-A+ (LD)	A+	Output
45	Phase-A- (LD)	A-	Output
46	Phase-B+ (LD)	B+	Output
47	Phase-B- (LD)	B-	Output
48	Phase-Z+ (LD)	Z+	Output
49	Phase-Z- (LD)	Z-	Output
50	Frame ground	FG	Output

Note: OC: open collector port, LD: line driver port

<<For absolute encoder system>>

Position mode

Pin	Signal	Symbol	I/O
1	Input signal common	IN-COM	Input
2	Clear	CLEAR	Input
3	Servo-ON	S-ON	Input
4	FWD inhibit	FWD-IH	Input
5	REV inhibit	REV- IH	Input
6	-	-	-
7	-	-	-
8	Input signal common	IN-COM	Input
9	-	-	-
10	Absolute data request	ABS-REQ	Input
11	Abs(multi-turn)data clear	ABS-CLEAR	Input
12	-	-	-
13	-	-	-
14	-	-	-
15	-	-	-
16	-	-	-
17	-	-	-
18	-	-	-
19	-	-	-
20	-	-	-
21	-	-	-
22	-	-	-
23	Speed monitor	SPD-MON	Output
24	Current monitor	CUR- MON	Output
25	Monitor ground	GND	Output
26	+24V	+24V	Input
27	FWD pulse+	FWD+	Input
28	FWD pulse-	FWD-	Input
29	REV pulse+	REV+	Input
30	REV pulse-	REV-	Input
31	-	-	-
32	-	-	-
33	In-position	IN-POS	Output
34	Alarm	ALARM	Output
35	-	-	-
36	-	-	-
37	Ready	READY	Output
38	Alarm-A+	ALM-A	Output
39	Alarm-B+	ALM-B	Output
40	Alarm-C+	ALM-C	Output
41	Alarm-D+	ALM-D	Output
42	Phase-Z (OC)	Z	Output
43	Output common	OUT-COM	Output
44	Phase-A+(LD)	A+	Output
45	Phase-A-(LD)	A-	Output
46	Phase-B+(LD)	B+	Output
47	Phase-B-(LD)	B-	Output
48	Phase-Z+(LD)	Z+	Output
49	Phase-Z-(LD)	Z-	Output
50	Frame ground	FG	Output

Note: OC: open collector port, LD: line driver port

Speed mode

Pin	Signal	Symbol	I/O
1	Input signal common	INPUT-COM	Input
2	Clear	CLEAR	Input
3	Servo-ON	S-ON	Input
4	FWD enable	FWD-EN	Input
5	REV enable	REV-EN	Input
6	Command change	CMD-CHG	Input
7	-	-	-
8	Input signal common	IN-COM	Input
9	-	-	-
10	Absolute data request	ABS-REQ	Input
11	Abs(multi-turn)data clear	ABS-CLEAR	Input
12	-	-	-
13	-	-	-
14	-	-	-
15	-	-	-
16	-	-	-
17	-	-	-
18	-	-	-
19	-	-	-
20	-	-	-
21	-	-	-
22	-	-	-
23	Speed monitor	SPD-MON	Output
24	Current monitor	CUR- MON	Output
25	Monitor ground	GND	Output
26	-	-	-
27	-	-	-
28	-	-	-
29	-	-	-
30	-	-	-
31	Speed command	SPD-CMD	Input
32	Speed command ground	SG-GND	Input
33	Attained speed	HI-SPD	Output
34	Alarm	ALARM	Output
35	-	-	-
36	-	-	-
37	Ready	READY	Output
38	Alarm-A+	ALM-A	Output
39	Alarm-B+	ALM-B	Output
40	Alarm-C+	ALM-C	Output
41	Alarm-D+	ALM-D	Output
42	Phase-Z (OC)	Z	Output
43	Output common	OUT-COM	Output
44	Phase-A+(LD)	A+	Output
45	Phase-A-(LD)	A-	Output
46	Phase-B+(LD)	B+	Output
47	Phase-B-(LD)	B-	Output
48	Phase-Z+(LD)	Z+	Output
49	Phase-Z-(LD)	Z-	Output
50	Frame ground	FG	Output

1-8 Operating display panel

The HA-655 driver provides a 6-digit LED display and four operation keys on the front panel. The panel executes monitoring, tuning, setting, and JOG operation.

1-8-1 Outlines of operation modes

The HA-655 driver provides the following four modes: monitoring, tuning, setting, and operations.

◆ Monitor mode

The HA-655 driver displays position and speed commands, a current position from a motor-encoder, a pulse count in an error counter, states of input and output signals, load conditions, alarm histories, and a code number for the actuator for which the driver is set. The mode can be used for diagnosing an abnormal driver.

After power supply, the monitor mode starts up and works as the hub of other three modes for operation.

◆ Tune mode

The tuning mode includes various parameters to control the actuator motion. Setting the most suitable value for each parameter obtains the optimum performance of the actuator.

◆ Parameter mode

The parameter mode sets various parameter values relating to the fundamental operational functions such as: specifications of the position mode or the speed mode, configurations of input signals, an electronic gear function, limiting values of speed and torque, and parameters to communicate with a host.

◆ Test mode

The test mode includes required functions for system tests; such as JOG operation functions, operations of pseudo output signals, I/O signal monitors, and so on.

1-8-2 Selecting a mode

After powering the driver, the monitor mode starts up automatically. The [ADJ] and [SET] keys select a mode.

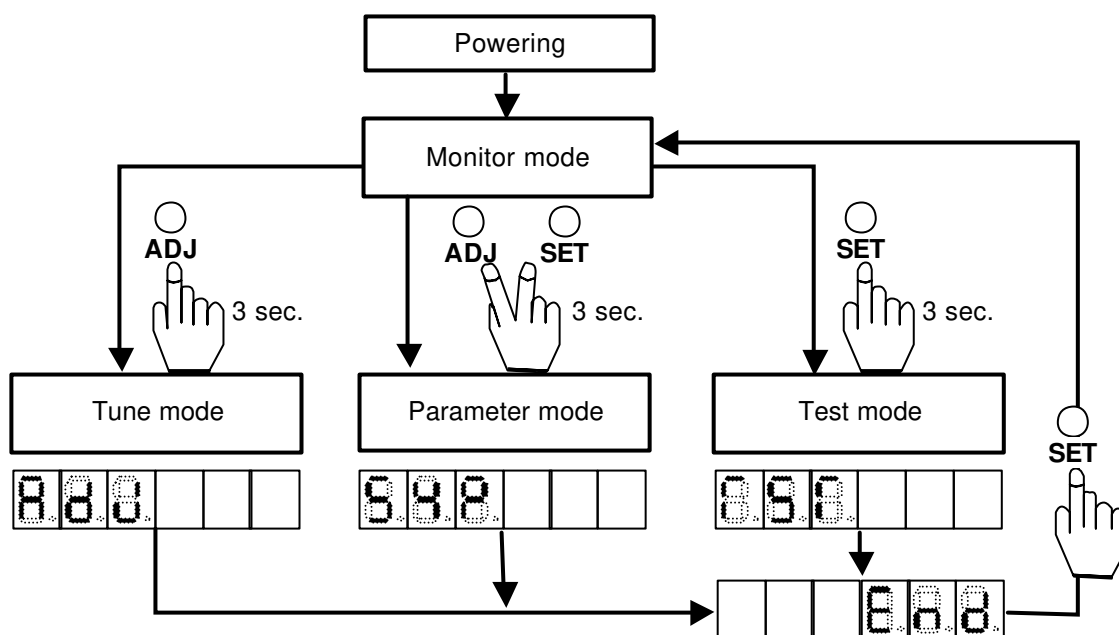

1-8-3 Functions in modes

Each mode individually provides the following functions of the position mode and the speed mode.

Mode	Code	Position mode	Setting	Code	Speed mode	Setting
Monitor mode	0	Error counter state	Impossible	0	Error counter state	Impossible
	1	Motor revolutions		1	Motor revolutions	
	2	-----		2	Speed command voltage	
	3	Error pulse count (Low)		3	Error pulse count (Low)	
	4	Error pulse count (High)		4	Error pulse count (High)	
	5	Torque monitor		5	Torque monitor	
	6	Overload rate		6	Overload rate	
	7	Feedback pulse (Low)		7	Feedback pulse (Low)	
	8	Feedback pulse (High)		8	Feedback pulse (High)	
	9	Command pulse (Low)		9	-----	
	A	Command pulse (High)		A	-----	
	b	Command pulse frequency		b	-----	
	c	I/O monitor		c	I/O monitor	
	d	Alarm history		d	Alarm history	
	E	Actuator code		E	Actuator code	
	F	-----		F	-----	
Tune mode	0	Speed loop gain	Possible	0	Speed loop gain	Possible
	1	S-loop integral compensation		1	S-loop integral compensation	
	2	Position loop gain		2	Position loop gain	
	3	Feed-forward gain		3	-----	
	4	In-position range	4	-----		
	5	-----	-----	5	Attained speed	Possible
	6	-----	-----	6	Internal speed command	
	7	-----	-----	7	Acceleration time constant	
	8	-----	-----	8	Deceleration time constant	
	9	-----	-----	9	Speed command offset	
Parameter mode	0	Control mode	Possible	0	Control mode	Possible
	1	Command configuration		1	-----	-----
	2	Multiplication of 2-phase pulse		2	-----	-----
	3	Electronic gear - denominator		3	-----	-----
	4	Electronic gear - numerator		4	-----	-----
	5	Error count cleared by S-ON		5	-----	-----
	6	Position error allowance	6	-----	-----	
	7	-----	-----	7	Zero clamp	Possible
	8	Rotary direction	8	Rotary direction		
	9	Speed conversion factor	9	Speed conversion factor		
	A	Speed limit	A	Speed limit		
	b	Torque limit	b	Torque limit		
	c	Alarm logic	c	Alarm logic		
	d	-----	-----	d	-----	
E	-----	-----	E	-----	-----	
f	ABS multi-turn data clear	Impossible	f	ABS multi-turn data clear	Impossible	
Test mode	Jo	JOG operation	Possible	Jo	JOG operation	Possible
	SP	JOG speed	Possible	SP	JOG speed	Possible
	Ac	JOG acceleration		Ac	JOG acceleration	
	InP	Output port operation	Possible	InP	Output port operation	Possible
	c	I/O monitor	Impossible	c	I/O monitor	Impossible
	An	Analog monitor manual output	Possible	An	Analog monitor manual output	Possible
	So	Speed command auto-offset	Possible	So	Speed command auto-offset	Possible

1-9 Outlines of protective functions

1-9-1 Alarms

HA-655 drivers provide various functions to protect actuators and drivers from the occurrence of abnormalities. When a function detect faults, the actuator enters a free rotation state, a two-digit alarm code is indicated on the display, and a set of 4-bit alarm signals is transmitted to the host.

Alarm code	Alarm description	4-bit code	ALM -D	ALM -C	ALM -B	ALM -A	Releasing
10	Over speed	1011	ON	OFF	ON	ON	Impossible
20	Over load	0001	OFF	OFF	OFF	ON	Possible
21	Overheat	1000	ON	OFF	OFF	OFF	Impossible
30	Over current	1001	ON	OFF	OFF	ON	Impossible
41	Abnormal regeneration	1010	ON	OFF	ON	OFF	Impossible
50	Encoder failure	1101	ON	ON	OFF	ON	Impossible
51	Abnormal encoder signal	1101	ON	ON	OFF	ON	Impossible
52	UVW failure	1101	ON	ON	OFF	ON	Impossible
53	*ABS system failure	1101	ON	ON	OFF	ON	Impossible
54	*ABS MTD over flow	1101	ON	ON	OFF	ON	Impossible
55	*ABS multi-turn data error	1101	ON	ON	OFF	ON	Impossible
56	*ABS low battery voltage	1101	ON	ON	OFF	ON	Impossible
57	*ABS send data rule error	1101	ON	ON	OFF	ON	Impossible
60	Error counter overflow	0010	OFF	OFF	ON	OFF	Possible
70	Memory failure (RAM)	0101	OFF	ON	OFF	ON	Impossible
71	Memory failure (EEPROM)	0101	OFF	ON	OFF	ON	Impossible
76	CPU failure	0100	OFF	ON	OFF	OFF	Impossible

Note: the alarm codes 53 through 57 are valid for absolute encoders only.

1-9-2 Protective functions

The HA-655 driver provides the following alarms to protect the servo system, and presents an alarm code on the preceding paragraph.

◆ Over speed (10)

If a motor exceeds its maximum speed or if motor rotates abnormally, the alarm occurs. To clear the alarm, shut off the control power once and turn it on again.

◆ Over load (20)

The driver always monitors the motor current, and if the current exceeds the curve in the figure below, the overload alarm occurs.

For example:

- (1) The alarm occurs if the current slightly exceeds 1.2 times of nominal current for a long duration.
- (2) The alarm occurs if the current of three times of the nominal current flows for 20 seconds.

It is possible to clear the alarm by inputting signal to [CN2-2 clear: CLEAR].

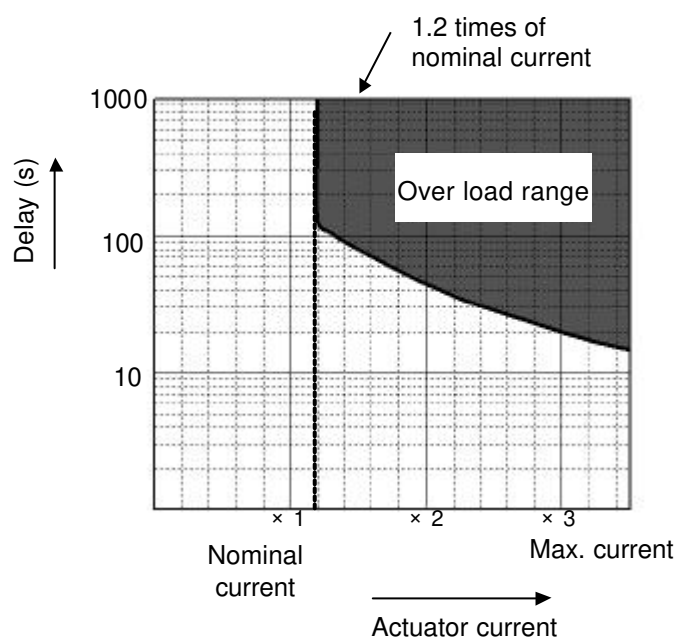

◆ Overheat (21)

The alarm occurs by activating the thermal switch of an IPM element in the HA-655 driver. To clear the alarm after troubleshooting, shut off the control power once and turn it on again.

◆ Over current (30)

The alarm occurs when the servo control element of the driver detects excessive current. To clear the alarm after troubleshooting, shut off the control power once and turn it on again.

◆ Abnormal regeneration (41)

The alarm occurs by activating the thermal switch of the regeneration resistor in the HA-655 driver at 100°C. To clear the alarm after troubleshooting, shut off the control power once and turn it on again.

◆ Encoder failure (50)

The alarm occurs when the encoder signal ceases. To clear the alarm after troubleshooting, shut off the control power once and turn it on again.

The alarm also occurs when a built-in battery of the HA-655 driver for the absolute encoder is taken off in spite of normal conditions. To clear the alarm, shut off the control power once and turn it on again.

◆ **Abnormal encoder signal (51)**

The alarm occurs when the driver has failed to receive two sequential signals. To clear the alarm after troubleshooting, shut off the control power once and turn it on again.

◆ **UVW failure (52)**

The alarm occurs when the encoder UVW signals are abnormal. To clear the alarm after troubleshooting, shut off the control power once and turn it on again.

◆ **ABS system failure (53)**

For the absolute encoder, the alarm occurs when all power supplies (power supply, built-in condenser, and battery) for the encoder are failure. For example, it occurs at the first power supply after purchasing, and at power supply after disconnecting the cable between the driver and the encoder for a long duration. To recover the alarm, input the multi-turn data clear signal at least 4 seconds, and shut off the control power once and turn it on again.

◆ **ABS MTD overflow (54)**

For the absolute encoder, the alarm occurs when the count for multi-turn data (MTD) goes beyond the range of +4095 to - 4096 turns (motor axis). To recover the alarm, input the multi-turn data clear signal at least 4 seconds, and shut off the control power once and turn it on again.

◆ **ABS multi-turn data error (55)**

For the absolute encoder, during an energy-saving mode, where no power by power supply but the encoder circuit is active only by the power of a built-in condenser and a built-in battery, the alarm occurs when the encoder rotates too fast at the acceleration rate and speed exceeding the recording ability of the multi-turn counter on the mode. To recover the alarm, input the multi-turn data clear signal at least 4 seconds, and shut off the control power once and turn it on again.

◆ **ABS low battery voltage (56)**

For the absolute encoder, when voltage of the built-in battery is low. To recover the alarm, change the battery for a new one, and shut off the control power once and turn it on again.

◆ **ABS send data rule error (57)**

The absolute encoder rotates more than 127 resolvable pulses by external torque during transmitting absolute data. To recover the alarm, shut off the control power once and turn it on again.

◆ **Error counter overflow (60)**

The alarm occurs when an error count exceeds the set value in [parameter mode] → [6: position error allowance]. It is possible to clear the alarm by inputting a signal to [CN2-2 clear: CLEAR]. The error count is cleared at the same time.

◆ **Memory failure (RAM) (70)**

The alarm occurs when the driver's RAM memory fails. It is impossible to clear the alarm.

◆ **Memory failure (EEPROM) (71)**

The alarm occurs when the driver's EEPROM memory fails. It is impossible to clear the alarm.

◆ **CPU failure (76)**

The alarm occurs when the driver's CPU fails. It is impossible to clear the alarm.

Chapter 2 Functions

2-1 Control system of the HA-655 driver

It is said that [plan, do, see] is essential to perform perfect jobs. In other words, the [plan, do, see] is the repeating cycle of command → action → result → feedback → modified command → action → feedback → Driving machines precisely requires the same control as the above job cycle, that is [Motion command → run → feedback → modified command →].

For example, assume the required motion is rotation to a target angle and stopping there. To perform the motion, the motor must be equipped with an angular sensor to detect a current position, and the position data must be compared with the command. If the position data is different than the command, the motor rotates until the position data becomes equal to the command. This is an example of a position servo system.

The speed control system is the same. The motor is equipped with a speed sensor and the speed is compared with the speed command. If the speed is different from the command, the motor accelerates or decelerates until the motor speed becomes equal to the command. This is an example of the speed servo system.

The HA-655 driver realizes above both controls of position and speed with the same unit.

The fundamental configuration of servo system of the HA-655 driver is as follows:

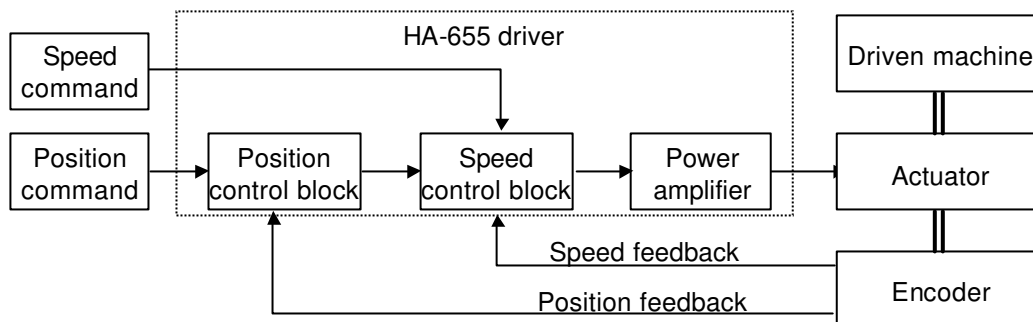

The HA-655 driver function is consists of three parts: the position control block, the speed control block, and the power amplifier.

In the position mode, a command position from a host is compared to a feedback position. If there is a difference between them, the position control block commands the power amplifier through the speed control block to flow current to the actuator until there is no difference.

In the speed mode, a speed command is directly inputted to the speed control block. The speed block compares the command and current feedback speed. If there is a difference between them, the speed control block commands to the power amplifier flow the current to the actuator until there is no difference.

The HA-655 driver allows two types of encoder as a functional member of the feedback system, optionally: an incremental encoder or an absolute encoder.

2-2 Position mode

The HA-655 driver makes use of either the position control or the speed control. This section describes the position mode. (※ The default setting is the [position mode].)

Before driving, set the control mode by [parameter mode] → [0: control mode].

2-2-1 Command configuration in position mode

In the position mode, the command is transmitted from a host in the form of a digital pulse signal train. The HA-655 driver provides two pair of two ports (CN2-27&28, CN2-29&30) for the command pulses. Signals of three type of configurations are available for the ports.

- **Setting a command configuration**

[Parameter mode] → [1: command configuration]

- **Relating I/O pins**

Input pins: CN2-26 to 30

(1) 2-pulse train (FWD and REV pulse train)

Two pairs of two terminals are provided, and each of FWD and REV pulse trains is assigned a pair independently. FWD commands and REV commands are inputted in the pair of FWD ports and REV ports respectively, as shown in the figure below. When signals are inputted to a pair of terminals, the signal to the other should keep [OFF] state.

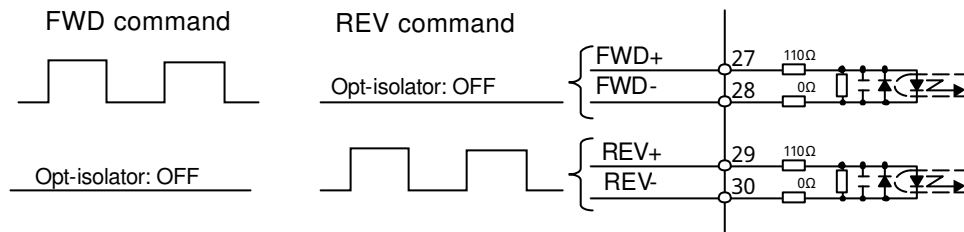

(2) 1-pulse train (polarity + pulse train)

One pair of terminals is assigned dedicatedly for command pulse train, and the other is assigned to a sign for rotary direction. Position commands are inputted in the FWD port pair only and the REV port pair accepts the sign of rotary direction, as shown in the figure below. [OFF] or [Low level] state is for the FWD command and [ON] or [High] level is for the REV command.

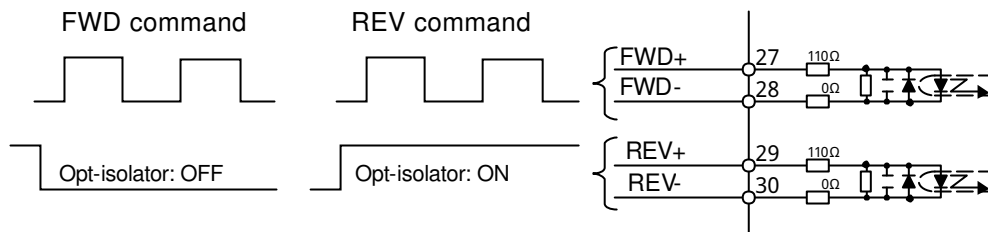

(3) 2-phase pulse train (A-B phase pulses with 90 degree difference)

Both port pairs receive the command pulse trains that have a 90 electric degree difference relative to each other as shown in the figure below. For the FWD command, the pulse train to the FWD ports advances 90 degrees from the REV port train. For the REV command, the REV port train advances from the FWD port train.

The encoder pulse trains to the driver have this 2-phase pulse configuration.

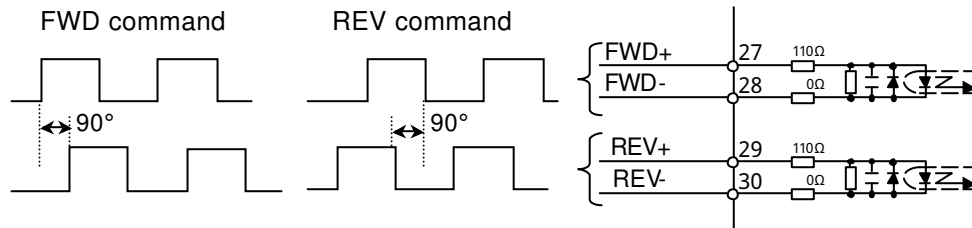

◆ Multiplication of command

When the command configuration is a [2-phase pulse] type, it is possible to multiply the command pulse train by 2 or 4 for the command pulse train to an actuator.

The encoder feedback pulse train is quadrupled.

• Setting

[Parameter mode] → [2: multiplication of 2-phase pulse]

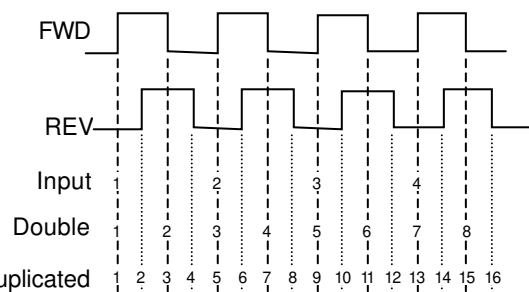

◆ Electronic gear

The electronic gear function can be set make a given displacement of the driven mechanism for one command pulse, an integer, or a convenient number. For example, it is convenient to set the displacement of 0.1 micrometer for one pulse as shown in figure to the right.

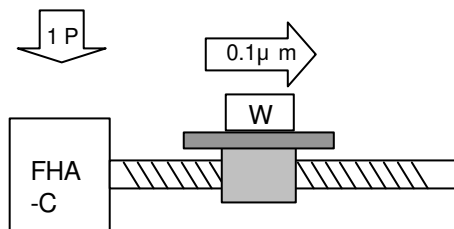

The function multiplies the command pulse count by the coefficient (fraction).

The relation of [denominator / numerator] of the coefficient is obtained as follows:

Rotary motion:

$$\frac{\text{Electronic gear - denominator}}{\text{Electronic gear - numerator}} = \frac{\text{Angle per pulse}}{\text{Reduction ratio of load}} \times \text{Actuator resolution} \times \frac{4}{360}$$

Linear motion:

$$\frac{\text{Electronic gear - denominator}}{\text{Electronic gear - numerator}} = \frac{\text{Displacement per pulse}}{\text{Feedpitch of driven mechanism}} \times \text{Actuator resolution} \times 4$$

With above formulas, each denominator and numerator should be set an integer between 1 and 50.

• Setting

[Parameter mode] → [3: electronic gear-denominator], and [4:electronic gear-numerator]

2-2-2 Command transmitting system

Two systems are provided for transmitting command pulses: [open collector] and [line driver].

◆ Open collector system

This system employs a transistor whose emitter is common and whose collector is open. Since the output signal is voltage type, this system is unsuitable for long distance transmission due to line voltage drop.

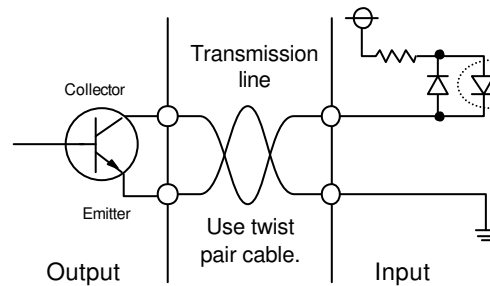

◆ Line driver system

The line driver system conforms to (EIA) RS-422 standard providing line drivers for transmitting signal pulses. Since the output signal is current type, this system is suitable for long distance transmissions without attenuation of signals.

Furthermore, the line driver system transmits data faster than the open collector system.

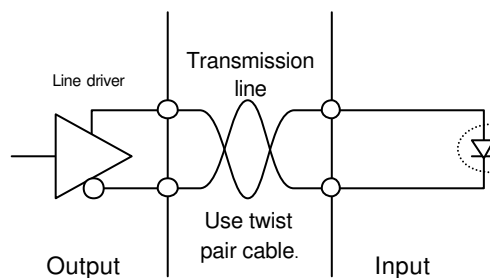

2-2-3 Outputting encoder signals

Two kinds of encoder are selectable for the FHA-C series actuator: incremental or absolute. The incremental encoder feeds back two pulse-trains into the HA-655 driver as shown in the figure to the right. The pulse trains are called [phase-A] and [phase-B]. For the encoder resolution, refer to actuator's technical manual.

On the other hand, the absolute encoder feeds back a combination of absolute signals and two pulse-train signals.

In addition to the 2-phase pulse trains, both encoders output a [phase-Z] pulse signal once per motor rotation for use as an origin. The pulse signal is sometimes called [phase-C] or [index].

The HA-655 driver outputs encoder signals using a line driver system. The signals can be received by a line receiver: AM26LS32 (EIA-422A) or equivalent. Phase-Z signal is also available (open collector output {CN-42 pin}).

The phase-Z signal is asynchronous.

Three encoder signals mentioned above are available for a host.

• Relating I/O pins

Output pins: CN2-42 to 49

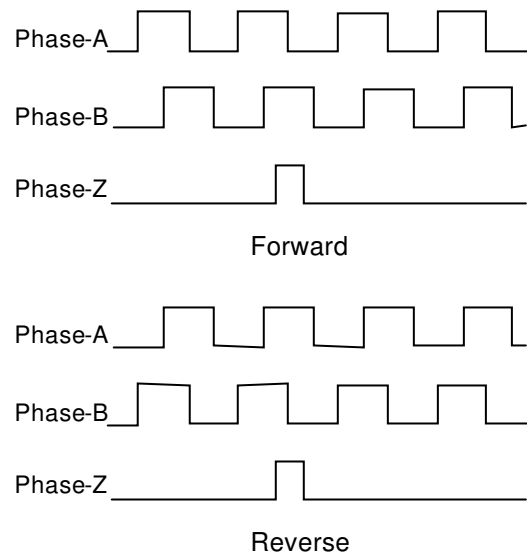

2-2-4 Absolute encoder signals

◆ General descriptions and functions of absolute encoders

The absolute encoder housed in a FHA-C series actuator provides an absolute sensor to generate an absolute pulse train for a resolvable position (the sensor is herein after referred to as “single-turn encoder”), and an electronic counter to generate an absolute pulse train for a revolution of the motor (the counter is hereinafter referred to as “multi-turn counter”).

An absolute position of the encoder is kept in the memory, which is always energized by a combination of the built-in condenser in the actuator and the backup battery housed in the HA-655 driver.

Please interpret that “single-turn” and “multi-turn” in the manual mean one and plural revolutions of the encoder (the motor) in an actuator, respectively. Therefore, the actual actuator resolvable position of either “single-turn” or “multi-turn” can be obtained by multiplying an absolute pulse train of the single-turn encoder and the multi-turn counter by a reduction ratio of the actuator.

◆ Single-turn absolute encoder

The single-turn encoder is composed of an encoder disk, an LED light source, and a photo-detector. The single-turn absolute encoder system outputs a current absolute pulse train combined with an absolute pulse train of the multi-turn counter in response to the [ABS data request] signal. The resolution of the encoder is 8192 positions per turn (13 bits). To obtain actual resolvable position of the actuator, the absolute pulse train should be multiplied by the reduction ratio of the actuator.

◆ Multi-turn counter

The multi-turn counter outputs a current absolute pulse train combined with an absolute pulse train of the single-turn absolute encoder system in response to the [ABS data request] signal. The allowed range of the counter is from +4095 to -4096. To obtain an actual resolvable position of the actuator, the absolute pulse train should be multiplied by the reduction ratio of the actuator.

◆ Energy-saving mode

In the energy-saving mode, even during no power supply for the HA-655 driver, the multi-turn counter keeps a count in its memory only by the power of a built-in condenser and a built-in battery.

◆ Allowable encoder (motor) speed in energy-saving mode

The limit of an encoder (a motor) speed is 5,000r/min. The [alarm 55: ABS multi-turn data error] occurs if the encoder rotates at more than the limited speed, and a correct absolute pulse train of the multi-turn counter may not be obtained. Moreover, there are additional limits during motor acceleration duration as shown the figure below.

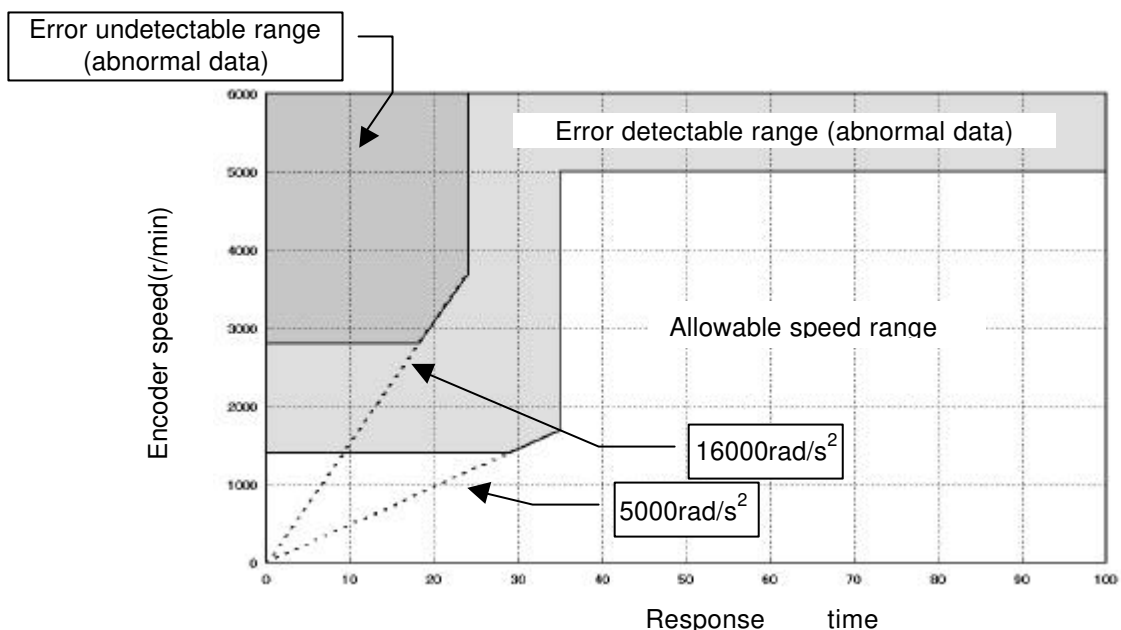

◆ **Notice at power on**

If power is turned on while the motor rotates at 2800r/min or more, the [Alarm 55] may occur. In spite of the alarm, the multi-turn counter works normal.

◆ **ABS (multi-turn) data clear signal (CN2-11: ABS-CLEAR)**

The ABS (multi-turn) data clear signal should be inputted at:

- (a) the initial power supply, and;
- (b) wasting about 30 minutes or more for exchanging the built-in battery.

At either case, the multi-turn counter does not keep any data. To recover from the problem, move the actuator to a proper origin and input the [ABS (multi-turn) data clear signal] at least four seconds to clear the multi-turn counter to zero. However, the single-turn encoder keeps its resolvable position during above-mentioned operation firmly.

During exchanging the battery, the built-in condenser helps the multi-turn counter to keep its count at least about 30 minutes with charged energy in the condenser. Therefore, the operation of inputting [ABS (multi-turn) data clear signal] is not required before discharging the energy.

Though the [alarm 50: encoder failure] may occur at power ON operation after exchanging the battery, the encoder system is normal. To recover the problem, shut off the power once and turn it on again.

◆ **Acquisition of absolute pulse trains generated by absolute encoder system**

The HA-655 driver provides two selectable acquisition methods of absolute pulse trains generated by the absolute encoder system; from I/O ports and from CN3 port (RS-232C).

(a) Acquisition from I/O ports (CN2-44, -45 and CN2-46, -47)

Acquiring an absolute pulse train

An absolute pulse train of an absolute encoder system is a combination of an absolute code (13 bits) of the multi-turn counter expressing an encoder's revolution number from its origin, and an absolute code (13 bits) of the single-turn encoder expressing a resolvable position of the encoder (the motor). Incremental signal trains following to the absolute pulse train of an absolute encoder system may be used for monitoring signals of operating condition of the motor.

As a rule, acquiring an absolute pulse train is possible only one time during power ON procedure illustrated below. If acquiring an absolute pulse train is required at another timing, use the CN3 port for acquiring while the motor is stopping.

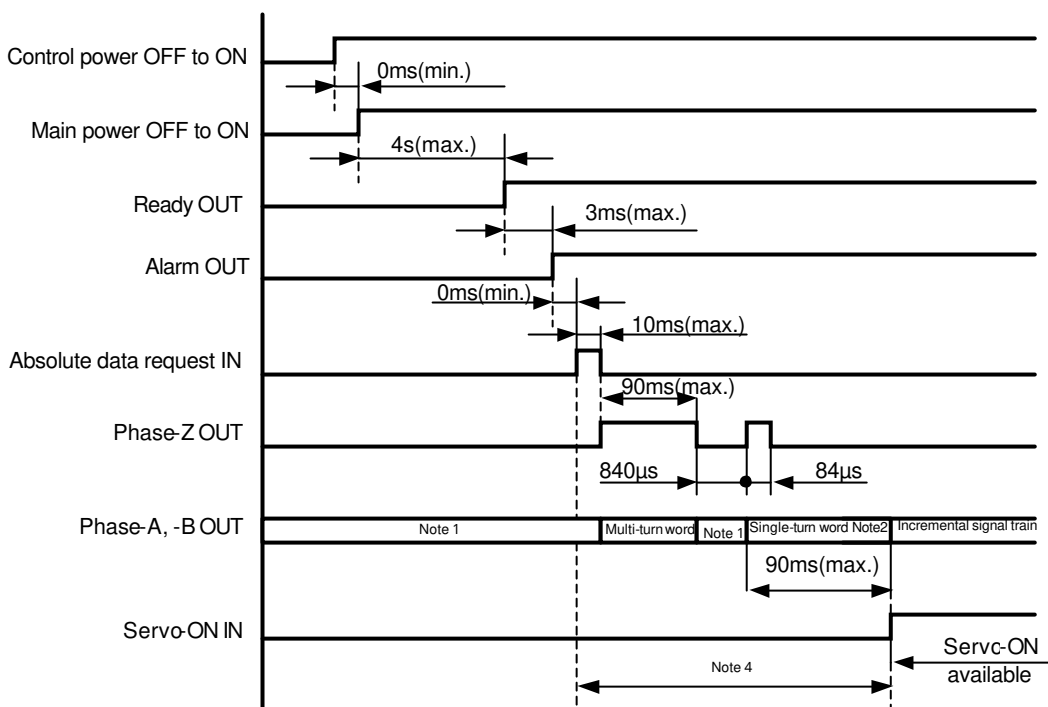

Note 1: Both output signals of phase-A and phase-B are settled at LOW-level. To settle at LOW-level, at least three pulses are outputted. Make a sequence for the host device ignoring outputted pulses while the phase-Z is LOW-level before generating an absolute pulse train, and during other LOW-level duration of the phase-Z signal.

Note 2: An absolute pulse train for single-turn encoder is outputted after around 1 ms of outputting phase-Z signal.

Note 3: The servo-ON signal is unaccepted until completing the transmission of a set of absolute pulse trains by the [absolute data request] signal.

Note 4: The [alarm 57] occurs if the single-turn encoder rotates more than 127 resolvable position while the multi-turn counter is transmitting an absolute pulse train.

Acquiring multi-turn count

For FWD revolution of the encoder (motor), the phase-A signal has 90 degree phase shift against phase-B signal, and for REV revolution the phase-A signal has 90 degree phase delay against phase-B signal as shown below.

Increasing or decreasing the multi-turn counter of the host device should be discriminated by the phase shift or delay of phase-A against phase-B. Acquire the signal at rising edge of the signal.

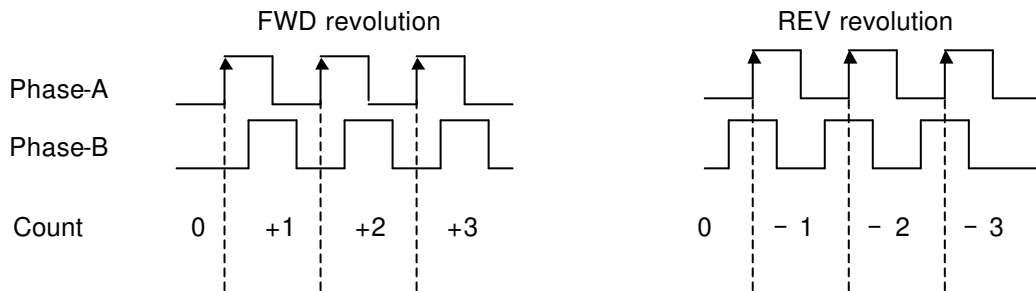

Acquiring single-turn encoder and incremental pulse trains

For FWD revolution of the encoder (motor), the phase-A signal has 90 degree phase shift against phase-B signal, and for REV revolution the phase-A signal has 90 degree phase delay against phase-B signal as shown below.

Increasing or decreasing the single-turn encoder counter of the host device should be discriminated by the phase shift or delay of phase-A against phase-B. Acquire the signal at rising and falling edge of the signal.

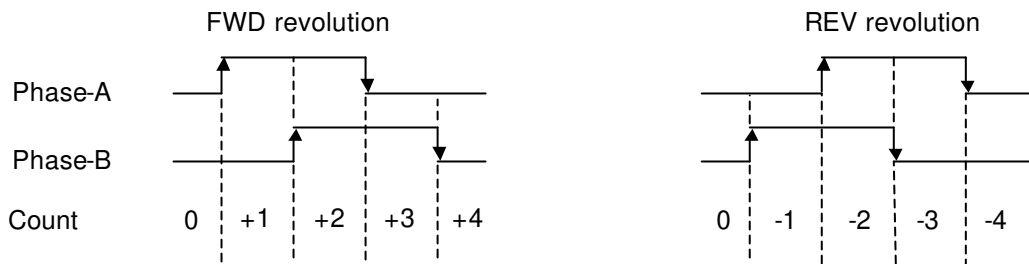

An example of signal transmission

The following is an example of the multi-turn count: 8, single-turn encoder count: 25 and an incremental pulse train at a usual operation.

The actual resolvable position of the encoder (motor) can be obtained by the calculation of:

$$\text{multi-turn count} \times 8192 + \text{single turn encoder count}$$

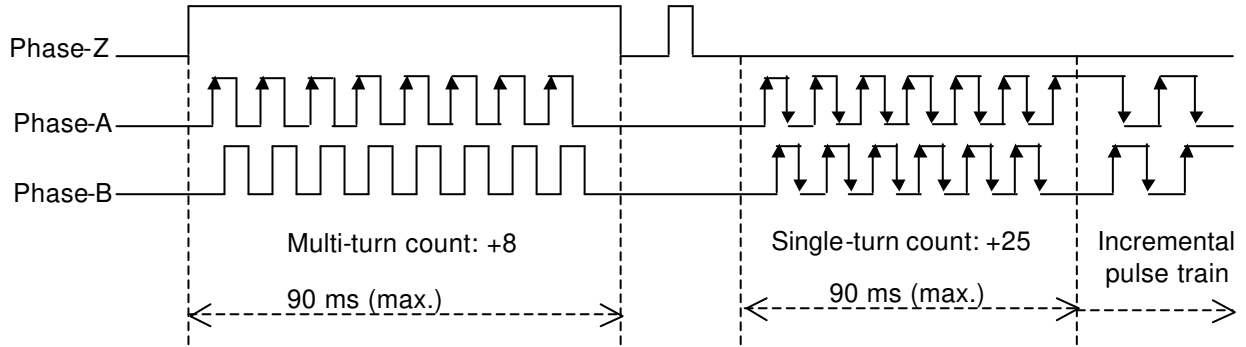

(b) Acquiring from CN3 port (RS-232C)

Connector specifications

Connect an RS-232C cable having following specifications between the CN3 port of the HA-655 driver and a RS-232C port of a host device.

Connectors: D-sub connector having 9 female pins

Pin assignments:

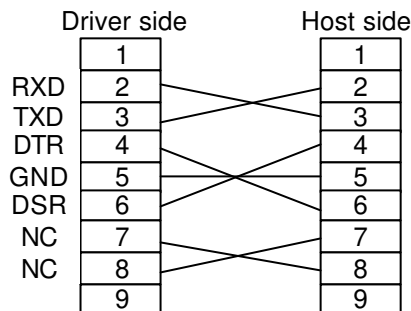

Communication format (RS-232C port setting)

Baud rate: 19200 bps

Data bits: 8 bit

Stop bits: 1 bit

Parity: None

Communication protocol

Sending a command to HA-655 driver (host → HA-655)

The command should be 10 characters in length including a delimiter as illustrated below. The HA-655 driver waits until receiving 10 characters without any processing. Make sure that the message has 10 characters including a delimiter.

XXX+ YYYYY Cr(delimiter: 0Dh)

Note: "0" means zero.

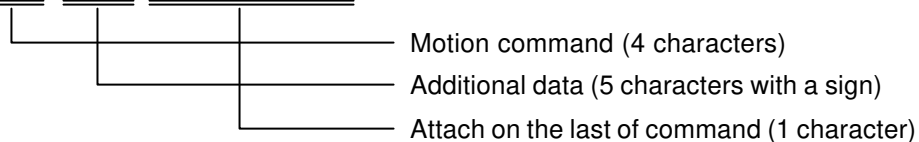

Receiving a message from HA-655 driver (HA-655 → host)

In case of requiring for data:

Data & 0Dh Note: "0" means zero.

then ;

q 0Dh Note: "0" means zero.

In case of not requiring for any data:

q 0Dh Note: "0" means zero.

When processing for a command from the host is finished and the HA-655 driver can accept a next command, the HA-655 driver responds to the host with "q 0dh" as described above. Then the HA-655 driver can accept the next command.

In spite of this, the HA-655 responds other codes as follows:

- servo ON condition (the motor is energized): no processing and acknowledgement is "s 0Dh";
- abnormal command form the host: acknowledgement is "x 0Dh".

Absolute Data request

Command from the host: DGR+ 00000 0Dh Note: "0" means zero.

Response from HA-655: XX· · · XX 0Dh (Note: XX· · · XX means a numerical data.)

q 0Dh Note: "0" means zero.

The absolute resolvable position is the data calculated by the formula of:

$$\text{Multi-turn count} \times 8192 + \text{single turn count}$$

If the position is negative (from an origin), the sign "-" is attached at the first position of the data, if it is positive, no sign is attached. The data is expressed in the ASCII decimal codes.

The host device can acknowledge data termination with the code "q 0Dh".

Note: The servo-ON signal is unaccepted until completing the transmission of a set of absolute pulse trains by the [absolute data request] signal.

Multi-turn data clear

Command from the host: OWW+ 00000 0Dh Note: "0" means zero.

Response from HA-655: q 0Dh for normal data clearing

x 0Dh for abnormal data clearing

If the data clearing process completes normally, the code "q 0Dh" may be acknowledged to the host after about 5 seconds from commanding.

If the process terminates abnormally, HA-655 driver acknowledges the code "x 0Dh" to the host, and quits the multi-turn data clearing process.

The abnormal termination may occur at cases as follows:

- servo ON condition (the motor is energized);
- the actuator equips an incremental encoder;
- the second multi-data commanding before receiving the acknowledgement for the first command (duplicated commands).

By the multi-turn data clearing, a discrepancy between the resolvable position count in the memory of HA-655 driver and the actual resolvable position count of the encoder comes into existence. To synchronize them, shut off the control power once and turn it on again, or send a reset command described below.

The reset command should be sent after 300 milliseconds or more from receiving the code “q 0Dh”, otherwise the [alarm 51: Abnormal encoder signal] may occur.

Reset

Command from the host:	ORW+ 00000 0Dh	Note: “0” means zero.
Response from HA-655:	q 0Dh	for normal resetting
	x 0Dh	for abnormal resetting

◆ **Back-up system for absolute data**

For protecting the absolute memory against volatilizing while control power is OFF, the absolute encoder system housed in the FHA-C actuator equips a condenser, and the HA-655 driver provides a battery.

Condenser:

Valid duration: about half hour after control power OFF
(conditions: charged at least 3 hours, at ambient temperature: 25 degree C, no rotation)

Battery:

Lifetime: about one year after control power OFF
(conditions: at ambient temperature: 25 degree C, no rotation)
actual lifetime depends on servicing conditions.

Specifications: lithium battery
model: ER17/33 (3.6V 1600mAh) manufactured by Hitachi Maxell co., Ltd.
Harmonic Drive Systems Inc. is possible to supply the batteries on request.

Exchanging procedures:

When [alarm 56: battery low voltage] occurs, exchange to new battery by the following procedure:

- (1) Shut off all power supply for the HA-655 driver.
- (2) Detach a cover of battery case on the front panel of the HA-655 driver.



- (3) Pull out the battery from the case by pulling both end of a ribbon.



- (4) Disconnect the leads of the battery from the junction connector.

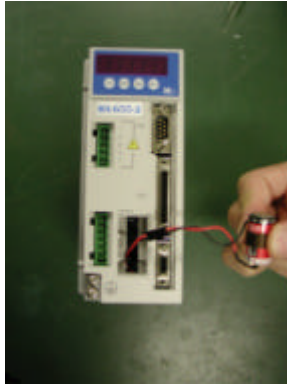

- (5) Connect the leads of the new battery to the junction connector.



- (6) Cram the battery with the leads and the connector into the case.
- (7) Attach a cover of battery case on the front panel of the HA -655 driver.
- (8) If [alarm 50: encoder failure] occurs at power ON operation after exchanging the battery, the encoder system is normal. To recover the problem, shut off the power once and turn it on again.
- (9) If [alarm 53: ABS system failure] occurs, the multi-turn counter does not keep any data. To recover from the problem, move the actuator to a proper origin and input the [ABS (multi-turn) data clear signal] for four seconds or more to clear the multi-turn counter to zero. However, the single-turn encoder keeps the absolute pulse train output during above-mentioned operation firmly.

Note: During exchanging the battery, the built-in condenser helps the multi-turn counter to keep its data for about 30 minutes or more with charged power in the condenser. Therefore, the operation of inputting [ABS (multi-turn) data clear signal] is not required in the case.

2-2-4 Tuning Servo gains

The HA-655 driver is fed back position and speed signals in the position mode as follows:

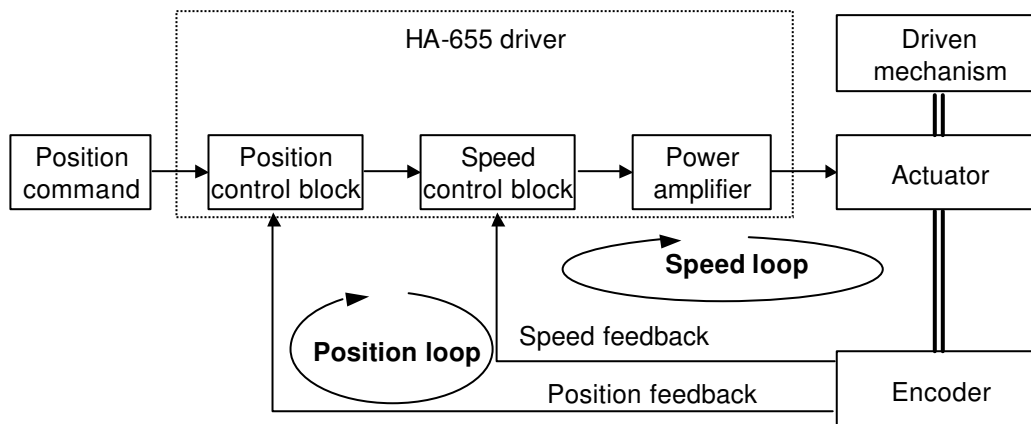

In the figure, the closed loop of [speed control block] → [power amplifier] → [actuator] → [encoder] → [speed control block] is called a [speed loop].

In the same manner, the closed loop of [position control block] → [speed control block] → [power amplifier] → [actuator] → [encoder] → [position control block] is called a [position loop].

The details of the loops are explained as follows:

◆ [Position control block] and [position loop gain]

- (1) The first function of the [position control block] is the [error count] calculation by the [error counter] in the block subtracting a feedback count from a command count.
- (2) The second function is the block that converts the [error count] to a [speed command] multiplying a factor, and then transmits the [speed command] to the [speed control block]. The factor (K_p) is called [position loop gain].

$$V = K_p \times \text{Error count}$$

It is clear in the formula that a large [error pulse] is converted into a high [speed command] and a zero pulse into a zero speed command, in other words, a stop command.

- (3) If the [position loop gain (K_p)] is high, a small [error count] is converted into a higher [speed command]. That is to say, higher gain provides the servo system with better response.

However, very high gain commands result in high [speed commands] from very minimal [error count] which will result in overshooting. To compensate for the overshoot the [position control block] generates a high speed reverse command, then overshoots in the opposite direction * * * finally hunting motion may take place.

Conversely, if the [position loop gain (K_p)] is very low, you will get very slow positioning motion (undershoot), and a poor servo response.

- (4) In conclusion, it is important to set the optimum value to the [position loop gain (K_p)]. The HA-655 driver has been set with the most suitable value for general applications as a factory default. If the load inertia is very heavy and the default is not suitable, tune it carefully.

● Tuning method

[Tune mode] → [2: position loop gain]

◆ **[Speed control block], [speed loop gain], and [speed loop integral compensation]**

- (1) The first function of the [speed control block] is to subtract a feedback signal from a command signal.
- (2) The second function is the block converts the difference to a [current command] multiplies it by a factor, and then transmits the [current command (I)] to the [power amplifier]. The factor (Kv) is called [speed loop gain].

$$I = K_v \times \text{speed difference}$$

It is clear in the formula that a significant [speed difference] is converted into a high [current command] and zero difference into zero current command, in other words, a stop command.

- (3) Just as with the [position loop gain], higher gain provides better response and excessive gain results in hunting. Low gain requires no hunting but raises the occurrence of undershoots.
- (4) The [speed loop integral compensation (Tv)] of The HA -655 driver makes less influence on load fluctuation.

$$I = K_v \times \left(1 + \frac{1}{T_v S} \right) \times \text{speed difference}$$

If the [speed loop integral compensation (Tv)] is smaller, the speed response to the load fluctuation becomes better, but too small a value results in hunting. Excessive compensation requires no hunting, but will result in a poor response for load fluctuation.

● **Tuning method**

[Tune mode] → [0: speed loop gain], and [1: speed loop integral compensation]

◆ **Feed forward gain**

- (1) In the position mode The HA-655 driver controls the error count, (the difference between [command pulse] and [feedback pulse]), to be [0]. At the beginning of inputting a command pulse train, the actuator starts slowly because of small error count.
- (2) The [feed forward] function may accelerate the actuator as much as possible, adding speed pulses converted from the command pulse frequency directly to the driver's speed control loop.

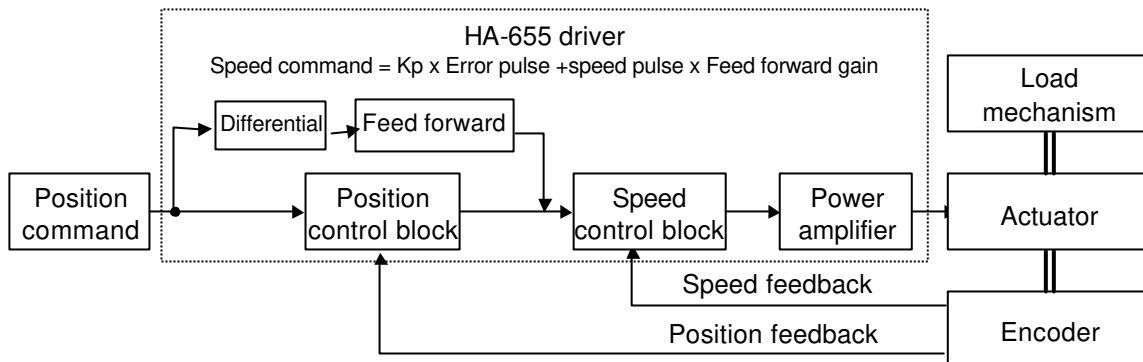

- (3) The relation between the feed forward and actuator motion is as follows:
 Higher feeding allows for better following to command, but excessive feeding results in hunting and erratic motion.
 Low feeding requires no hunting but a poor following of the command.

● **Tuning method**

[Tune mode] → [3: Feed forward]

2-2-5 FWD inhibit and REV inhibit

The HA-655 driver provides [FWD inhibit] and [REV inhibit] input signal ports.

[FWD inhibit]: opening (OFF) the input inhibits forward rotation.

[REV inhibit]: opening (OFF) the input inhibits reverse rotation.

Opening (OFF) both inputs inhibits all rotation.

The inputs may be used to limit the motion range between limit sensors.

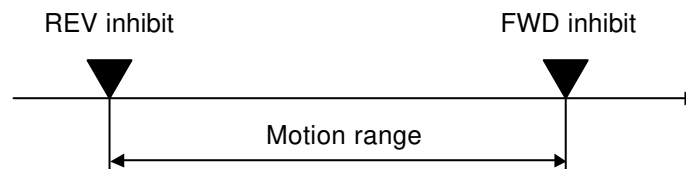

- **Connection**

Refer to [CN2-1: input signal common], [CN2-4: FWD inhibit], and [CN2-5: REV common].

2-2-6 In-position

In the position mode, even though the driver controls the actuator to make the [error count 0], it is not always possible due to the influence of external forces, acceleration, and deceleration. Establishing a positioning allowance is a good solution to the problem; that is [in-position range].

[Tune mode] → [4: in-position range] sets the allowance. The actuator position comes within the range calculated with the formula below, the [CN2-33: in-position] signal outputted.

$$\text{Actuator position} \leq \text{Command position} \pm \text{In-position range}$$

- **Relating I/O signal pin**

Output pin: CN2-33

- **Tuning method**

[Tune mode] → [4: In-position range]

2-3 Speed mode

The HA-655 driver makes use of either the position control or the speed control. This section describes the speed mode. (※ The default setting is the [position mode].

Before running, set the control mode by [parameter mode] → [0: control mode].

2-3-1 Speed conversion factor

In the speed mode, the command is sent from a host with an analog voltage signal. The [speed conversion factor] converts the [speed command] voltage to motor speed.

The [speed conversion factor] is the motor speed when the [speed command voltage] is [10V]. The actual motor speed is obtained by the following formula:

$$\text{Motor speed} = \text{Command voltage} \times \frac{\text{Speed conversion factor}}{10.0\text{V}}$$

The [speed monitor] (SPD-MON: CN2-23pin) output voltage as follows:

$$\text{Speed monitor voltage} = \text{Motor speed} \times \frac{10.0\text{V}}{\text{Speed conversion factor}}$$

- **Setting**

[Parameter mode] → [9: speed conversion factor]

2-3-2 Voltage of speed command

Input the voltage converted by the [speed conversion factor] into [CN2-31: speed command] and [CN2-32: speed command common] pins. The [speed command voltage] is obtained by [parameter mode] → [9: speed conversion factor].

$$\text{Speed command voltage} = \text{Motor speed} \times \frac{10.0\text{V}}{\text{Speed conversion factor}}$$

- ◆ **FWD enable and REV enable**

The HA-655 driver provides [FWD enable] and [REV enable] input ports. The rotary direction of the actuator is decided by the polarity of [CN2-31: speed command SPD-CMD] and ON/OFF states of [FWD enable] and [REV enable] as shown in the table below:

CN2-31 Speed cmd.: SPD-CMD		+ Command		- Command	
CN2-4	FWD enable: FWD-EN	ON	OFF	ON	OFF
CN2-5	REV enable: ON	Zero clamp, zero speed	REV rotation	Zero clamp, zero speed	FWD rotation
	REV-EN OFF	FWD rotation	Zero clamp, zero speed	REV rotation	Zero clamp, zero speed

- **Relating input pins**

CN2-31: speed command, CN2-32: speed command common, CN2-4: FWD enable, CN2-5: REV enable

- ◆ **Speed command offset**

In the speed mode, the motor may rotate slightly in spite of a [0V] speed command voltage. This problem may occur when the speed command voltage has an offset of a few milli-volts. This function removes the slight rotation compensating the command voltage offset.

While inputting a [0V] command voltage adjust the speed command offset until the actuator stops rotating.

[Speed command automatic offset] function is also provided.

- **Setting**

[Tune mode] → [9: speed command offset], [test mode] → [So: Speed command automatic offset]

2-3-3 Tuning servo gains

The HA-655 driver is fed back position and speed signals in the speed mode as follows:

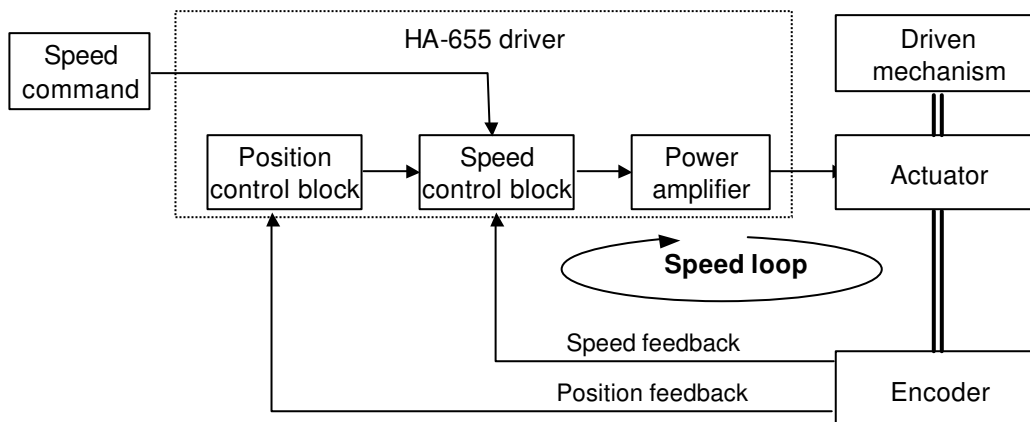

In the figure, the closed loop of [speed control block] → [power amplifier] → [actuator] → [encoder] → [speed control block] is called [speed loop].

The details of the loop are described as follows:

- ◆ **[Speed control block], [speed loop gain], and [speed loop integral compensation]**

- (1) The first function of the [speed control block] is to subtract a feedback signal from a command signal.
- (2) The second function is when the block converts the difference to a [current command] multiplies it by a factor, and then transmits the [current command] to the [power amplifier]. The factor (K_v) is called [speed loop gain].

$$I = K_v \times \text{speed difference}$$

It is clear in the formula that a [speed difference] is converted into a high [current command], and a zero difference into a zero current command, in other words, a stop command.

- (3) If the [speed loop gain (K_v)] is high, a small [speed command] is converted into a higher [current command]. That is to say, higher gain provides the servo system with a better response.

However, very high gain settings can cause a very high [current command] in response to a small [speed command] which will result in overshooting. To compensate overshooting, the [speed control block] generates a high speed reverse command, then finally hunting motion may take place.

- (4) Conversely, if the [speed loop gain (K_v)] is very low, you will get very slow positioning motion (undershoot) and poor servo response.
- (5) The [speed loop integral compensation (T_v)] of the HA-655 driver minimizes the influence of load fluctuation.

$$I = K_v \times \left(1 + \frac{1}{T_v S} \right) \times \text{speed difference}$$

If the [speed loop integral compensation (T_v)] is low, the speed response to the load fluctuation becomes better, but very small value can result in hunting. Excessive compensation requires no hunting but a poor response for load fluctuation.

- **Setting**

[Tune mode] → [0: speed loop gain], [1: speed loop integral compensation]

2-3-4 Command change

The function can operate the actuator without command at the speed specified by [tune mode] → [6: internal speed command]. This is convenient for diagnosis and for test operation without hosts.

The actuator will rotate at the speed set by the [internal speed command] when a signal is input to CMD-CHG (CN2-6) and stops when the signal is removed.

- **Relating I/O pin**

Input pin: CN2-6

2-3-5 Acceleration / deceleration time constants

[Acceleration time constant] is the time it takes to accelerate the motor from [0 r/min] to the speed of [A: speed limit] of [parameter mode].

[Deceleration time constant] is the time it takes to decelerate the motor from the speed of [A: speed limit] of [parameter mode] to [0 r/min].

The deceleration time to speed command voltage is as follows:

$$\text{Accel/Decel time} = \text{Accel/Decel timeconst} \times \frac{\text{Command voltage}}{\text{Speedlimit}} \times \frac{\text{Speedconversionfactor}}{10}$$

2-3-6 Zero clamp

In the speed mode when [speed command] is [0], the actuator may rotate slightly by force from the driven mechanism. The [Zero clamp] function forcefully stops the actuator when the speed command is [0].

- **Setting**

[Parameter mode] → [7: zero clamp]



Take cares that the servo-lock function does not work and the actuator is free to rotate when:

- main and/or control power are not supplied;.
- servo-ON signal is not inputted;
- an alarm occurs.

2-4 Other functions

2-4-1 Indicating of pulse counts

As shown in the figure to the right, the motion command pulses are transmitted to the HA-655 driver from a host. The driver drives the actuator corresponding to the motion command. When the actuator starts, the position pulses are sensed by the encoder and are fed back to the driver. The HA-655 driver continues to drive the actuator until the error count (difference between command count and feedback count) comes to zero.

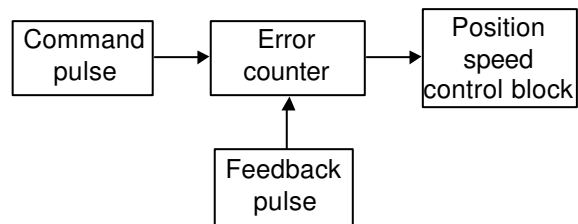

In the monitor mode, [command pulse], [feedback pulse], and [error pulse] can be monitored. This function may be effective for diagnosis.

- **Indications**

[Tune mode] → [3,4: error counter status], [7,8: feedback pulse], [9,A: command pulse]

2-4-2 Manual JOG operation

It is possible to operate the actuator manually for test, for tuning, and for diagnosis without commands from a host. Pressing the [UP] and [DOWN] keys on the front panel rotates the actuator at pre-set speed and at pre-set acceleration.

- **Operation and setting**

[Test mode] → [Jo: JOG operation], [SP: JOG speed], [Ac: JOG acceleration]

2-4-3 Monitoring inputs and operating outputs

It is possible to monitor input ports of [clear], [servo-ON], [FWD inhibit] and [REV inhibit] for test, for tuning, and for diagnosis.

It is also possible to manually output signals of [in-position], [attained speed], [alarm] and so on without relations to the actuator state by pressing the [UP] and [DOWN] keys on the front panel outputs signals.

- **Operation and setting**

[Test mode] → [b : I/O monitor], [InP : Output port operation]

Chapter 3 I/O ports

Through the CN2 connector (50 pins; half pitch) the HA-655 driver communicates with a host. Details of the I/O ports are described in this chapter.

As the functions of the pins of the connector differ in each control mode, the functions are described separately by modes.

3-1 Position mode

3-1-1 I/O port layout

<< for incremental encoder system >>

The I/O port layout is shown as follows:

※ Do not use the pins marked “-”.

Pin	Signal name	Symbol	I/O
1	Input signal common	IN-COM	Input
2	Clear	CLEAR	Input
3	Servo-ON	S-ON	Input
4	FWD inhibit	FWD-IH	Input
5	REV inhibit	REV-IH	Input
6	-	-	-
7	-	-	-
8	Input signal common	IN-COM	Input
9	-	-	-
10	-	-	-
11	-	-	-
12	-	-	-
13	-	-	-
14	-	-	-
15	-	-	-
16	-	-	-
17	-	-	-
18	-	-	-
19	-	-	-
20	-	-	-
21	-	-	-
22	-	-	-
23	Speed monitor	SPD-MON	Output
24	Current monitor	CUR-MON	Output
25	Monitor ground	GND	Output

Pin	Signal name	Symbol	I/O
26	+24V	+24V	Input
27	FWD pulse+	FWD+	Input
28	FWD pulse-	FWD-	Input
29	REV pulse+	REV+	Input
30	REV pulse-	REV-	Input
31	-	-	-
32	-	-	-
33	In-position	IN-POS	Output
34	Alarm	ALARM	Output
35	-	-	-
36	-	-	-
37	-	-	-
38	Alarm-A+	ALM-A	Output
39	Alarm-B+	ALM-B	Output
40	Alarm-C+	ALM-C	Output
41	Alarm-D+	ALM-D	Output
42	Phase-Z (OC)	Z	Output
43	Output common	OUT-COM	Output
44	Phase-A+ (LD)	A+	Output
45	Phase-A- (LD)	A-	Output
46	Phase-B+ (LD)	B+	Output
47	Phase-B- (LD)	B-	Output
48	Phase-Z+ (LD)	Z+	Output
49	Phase-Z- (LD)	Z-	Output
50	Frame ground	FG	Output

Note: OC: open collector port, LD: line driver port

<< for absolute encoder system >>

The I/O port layout is shown as follows:

※ Do not use the pins marked “-”.

Pin	Signal name	Symbol	I/O
1	Input signal common	IN-COM	Input
2	Clear	CLEAR	Input
3	Servo-ON	S-ON	Input
4	FWD inhibit	FWD-IH	Input
5	REV inhibit	REV-IH	Input
6	-	-	-
7	-	-	-
8	Input signal common	IN-COM	Input
9	-	-	-
10	Absolute data request	ABS-REQ	Input
11	Abs(multi-turn)data clear	ABS-CLEAR	Input
12	-	-	-
13	-	-	-
14	-	-	-
15	-	-	-
16	-	-	-
17	-	-	-
18	-	-	-
19	-	-	-
20	-	-	-
21	-	-	-
22	-	-	-
23	Speed monitor	SPD-MON	Output
24	Current monitor	CUR-MON	Output
25	Monitor ground	GND	Output

Pin	Signal name	Symbol	I/O
26	+24V	+24V	Input
27	FWD pulse+	FWD+	Input
28	FWD pulse-	FWD-	Input
29	REV pulse+	REV+	Input
30	REV pulse-	REV-	Input
31	-	-	-
32	-	-	-
33	In-position	IN-POS	Output
34	Alarm	ALARM	Output
35	-	-	-
36	-	-	-
37	Ready	READY	Output
38	Alarm-A+	ALM-A	Output
39	Alarm-B+	ALM-B	Output
40	Alarm-C+	ALM-C	Output
41	Alarm-D+	ALM-D	Output
42	Phase-Z (OC)	Z	Output
43	Output common	OUT-COM	Output
44	Phase-A+ (LD)	A+	Output
45	Phase-A- (LD)	A-	Output
46	Phase-B+ (LD)	B+	Output
47	Phase-B- (LD)	B-	Output
48	Phase-Z+ (LD)	Z+	Output
49	Phase-Z- (LD)	Z-	Output
50	Frame ground	FG	Output

Note: OC: open collector port, LD: line driver port

3-1-2 Models of I/O port connector CN2

The models of the CN2 connector is as follows:

Connector: 10150-3000VE 3M

Cover: 10350-52F0-008 3M

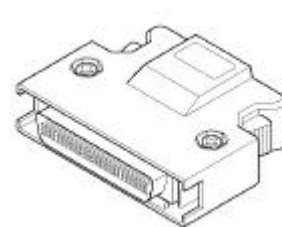

3-1-3 I/O port connections in the position mode

This section describes the connection between the I/O ports and a host in the position mode.

Inputs:

The HA-655 driver provides six ports for inputs as shown in the figure to the right.

◆ **Specifications**

Voltage: DC24V ± 10%
 Current: 20mA or less
 (for each port)

An input port circuit is shown in the figure to the right. The ports marked with (*) are available for absolute encoder system only.

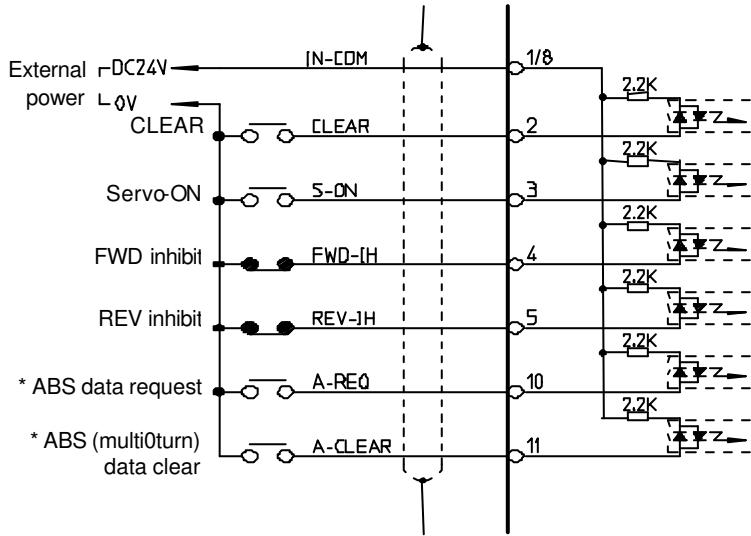

• **Connection**

The HA-655 driver does not provide the power supply for input signals. Connect a [+24V] power supply for the signals to [CN2-1: input signal common].

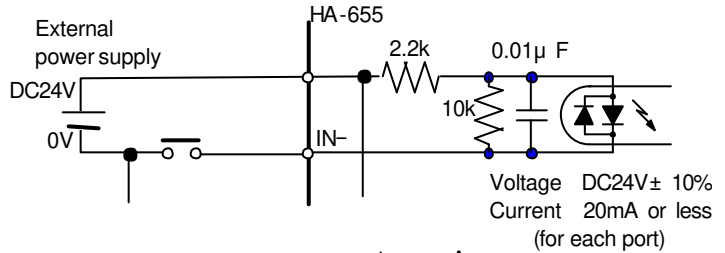

Outputs:

The HA-655 driver provides eight ports for outputs as shown in the figure to the right.

◆ **Specifications**

Port: Open collector
 Voltage: DC24V or less
 Current: 40mA or less
 (for each port)

All ports are insulated by opto-isolators.

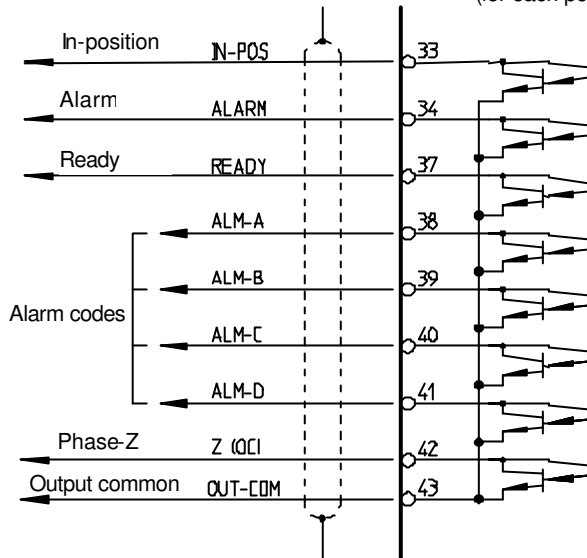

An output port circuit is shown in the figure to the right.

• **Connection**

Connect output signals between their respective output ports and [CN2-43: output common] port.

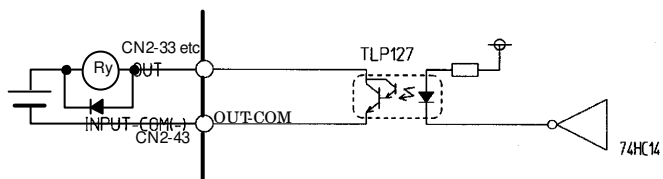

3-1-4 I/O port functions in the position mode

This section describes I/O port functions in the position mode.

CN2-1 Input signal common: IN-COM (input)

- **Function**

This is the common port for inputs: [CN2-2, -3, -4, -5, -10, -11]. Supply external power for inputs to this the port.

- **Connection**

Connect [+24V] external power supply for inputs here.

CN2-2 Clear: CLEAR (input)

- **Function**

(1) If alarm exists:

This clears the alarm state, returns to operable state, and clears the error count to [0]. For alarms that cannot be cleared, shut off the control power once, and turn it on again.

(2) If no alarm exists:

This clears the error count to [0]. At the same time, this clears the command count and the feedback count.

- **Connection**

Connect [NO-contact signal (a-contact)]. Refer to [CN2-1: input signal common].

CN2-3 Servo-ON: S-ON (input)

- **Function**

This turns the servo power for the HA-655 driver ON and OFF.

When the input is ON, the servo power of the HA-655 driver is ON and the actuator can be driven. When OFF, the servo power turns OFF and the motor is free to rotate.

- **Connection**

Connect [NO-contact signal (a-contact)]. Refer to [CN2-1: input signal common].

CN2-4 FWD inhibit: FWD-IH (input)

CN2-5 REV inhibit: REV-IH (input)

- **Function**

[FWD inhibit]: open state (OFF) of the input inhibits forward rotation.

[REV inhibit]: open state (OFF) of the input inhibits reverse rotation.

Open states (OFF) of both inputs inhibit rotation.

The inputs may be used to limit the motion range between limit sensors.

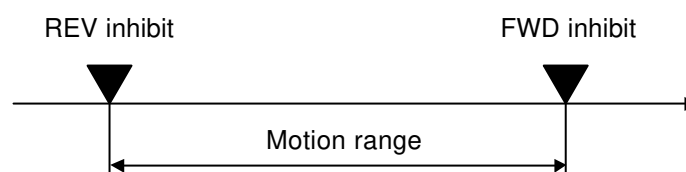

- **Connection**

Normally, connect [NC-contact signal (b-contact)]. Refer to [CN2-1: input signal common].

CN2-8 Input common: IN-COM(input)**Function**

The same functions as CN2-1

CN2-10 absolute data request: ABS-REQ(input) *absolute encoder system only**Function**

The input is used for a command to output a current resolving count of the encoder.

CN2-11 ABS (multi-turn) data clear: ABS-CLEAR(input) *absolute encoder system only**Function**

The input uses for a command to clear a current resolving count of the multi-turn counter to zero.

CN2-23 Speed monitor: SPD-MON (output)

- Function**

The port outputs a voltage signal proportional to the motor speed. The actual motor speed is obtained by the following formula:

$$\text{Motor speed} = \text{Command voltage} \times \frac{\text{Speed conversion factor}}{10.0\text{V}}$$

- Specifications of output:
 - Voltage range: -15V to +15V
 - Output impedance: 1k Ω

- Connection**

Connect the monitor to the ports of [CN2-23: speed monitor: SPD-MON] and [CN2-25: GND].

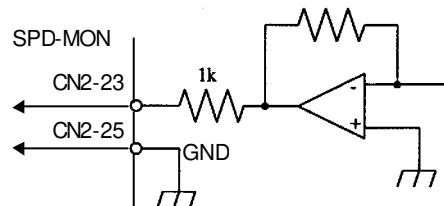
**CN2-24 Current monitor: CUR-MON (output)**

- Function**

The port outputs a voltage signal proportional to the motor current. The relation between the voltage and the current is set so that the monitor voltage of [+10V] corresponds to the actuator maximum current.

$$\text{Monitor voltage(V)} = \text{Actuator current} \times \frac{10}{\text{Actuator maximum current}}$$

- Specifications of output:
 - Voltage range: -15V to +15V
 - Output impedance: 1k Ω

- Connection**

Connect the monitor to [CN2-24: current monitor: CUR-MON] and [CN2-25: GND].

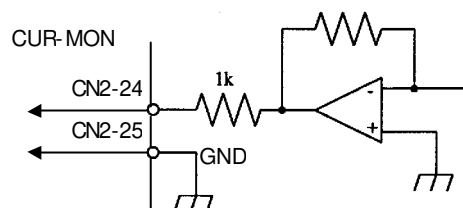
**CN2-25 Monitor ground: GND**

- Function**

This is the common port for the monitor ports [CN2-23, -24].

CN2-26 +24V: +24V (input)

CN2-27 FWD pulse+: FWD+ (input)

CN2-28 FWD pulse-: FWD- (input)

CN2-29 REV pulse+: REV+ (input)

CN2-30 REV pulse-: REV- (input)

• **Function**

These ports receive position commands in the position mode.

The both [line driver] and [open collector] can be used for the commands. For the [open collector] system, both signal voltage of [+24V] and [+5V] are acceptable. The connection to the ports is different in the selections.

Note 1: The port [CN2-26 +24V] is not a power supply. The HA-655 driver does not have an internal power supply for inputs.

Note 2: Three types of command configurations of [2-pulse],[1-pulse],[2 phase pulse] are available by setting [parameter mode] → [1: command configuration]. This has no effect on the connection specifications.

• **Connection**

The details of the input ports are shown in the figure below.

Specifications of the input ports are as follows:

Specifications of the input ports

- (1) Power voltage:
In case of +24V: +24V± 10%
In case of +5V: +5V± 10%
- (2) Current I: 16mA
(less than 20mA)

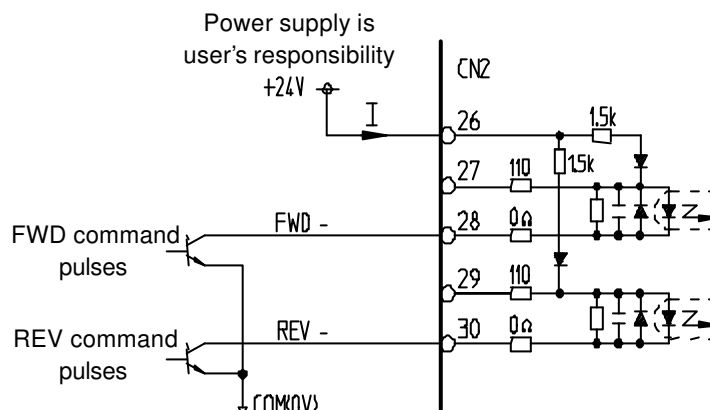

◆ **Connections for Line driver command**

- (1) Connect FWD command to [CN2-27: FWD+] and [CN2-28: FWD-].
- (2) Connect REV command to [CN2-29: REV+] and [CN2-30: REV-].
- (3) Open [CN2-26: +24V].

Note: Use line drivers of EIA-422A standard.

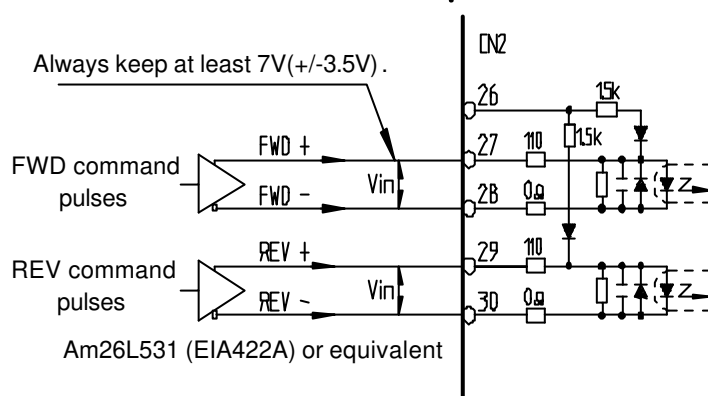

◆ **Connection for open collector commands and +24V power supply**

- (1) Connect FWD command to [CN2-28: FWD-] and [+24V].
- (2) Connect REV command to [CN2-30: REV-] and [+24V].
- (3) Connect [+24V] of external power supply to [CN2-26: +24V].
- (4) Plan the command circuit for the ports as follows:
 Supply voltage: +24V± 10%
 Signal current: 16mA (less than 20mA)

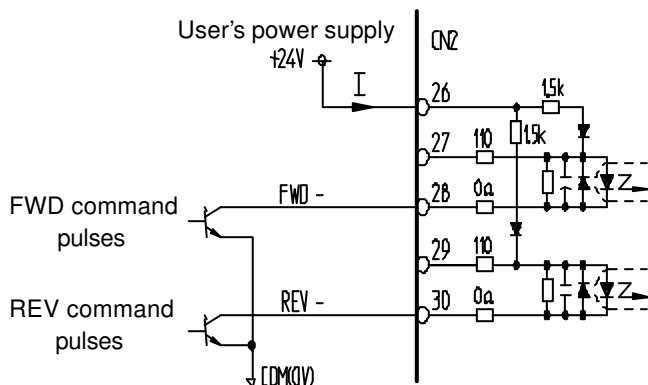

◆ **Connection for open collector commands and +5V power supply**

- (1) Connect FWD command to [CN2-27: FWD+] and [CN2-28: FWD-].
- (2) Connect REV command to [CN2-29: REV+] and [CN2-30: REV-].
- (3) Open [CN2-26: +24V].
- (4) Plan the command circuit for the ports as follows:
 Supply voltage: +5V± 10%
 Signal current: 16mA (less than 20mA)

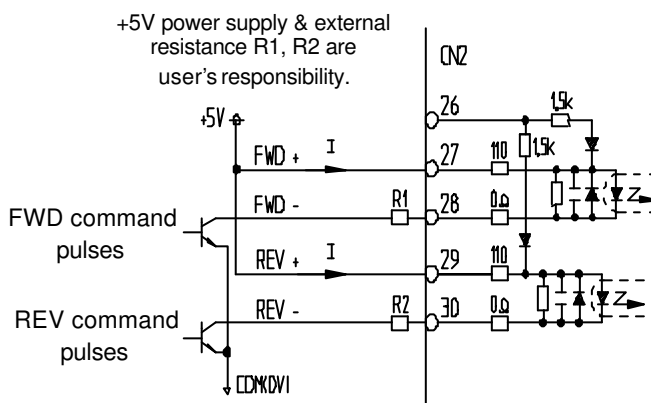



The connections are deferent by the supply voltage.
 The pin numbers to be connected are deferent by the supply voltage of [+5V] or [+24V].
 The wrong connection may damage the driver.

CAUTION

CN2-33 In-position: IN-POS (output)

• **Function**

The signal is outputted when the error count becomes less than the value of [tune mode] → [4: in-position range]. The output may be used to confirm proper positioning.

• **Connection**

- (1) The figure to the right is a connection example of [CN2-33 in-position: IN-POS] port.
- (2) Plan the output circuit for the ports as follows:
 Supply voltage: +24V or less
 Signal current: 40mA or less
 (for each port)

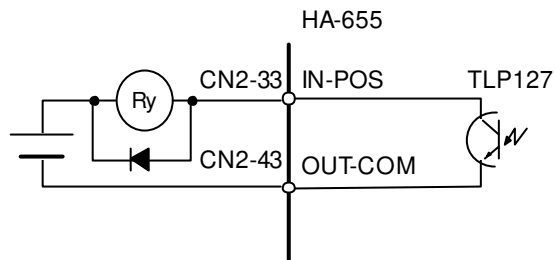

CN2-34 Alarm: ALARM (output)

- **Function**

The output turns OFF when the HA-655 driver senses an alarm.

- **Connection**

- (1) An example of [CN2-34 alarm: ALARM] connection is shown in the figure below.
- (2) Plan the output circuit for the ports as follows:
 Supply voltage: +24V or less
 Signal current: 40mA or less

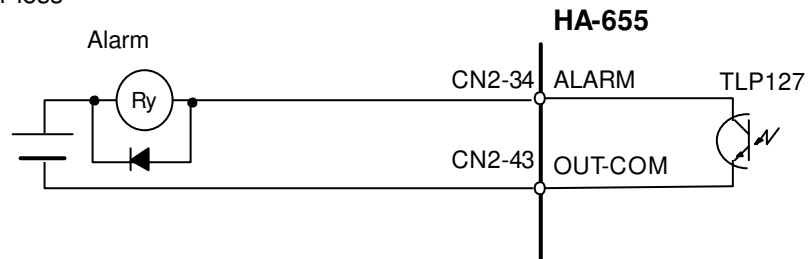

CN2-37 Ready: READY (output)

- **Function**

The output turns ON when the HA-655 driver is ready to drive.

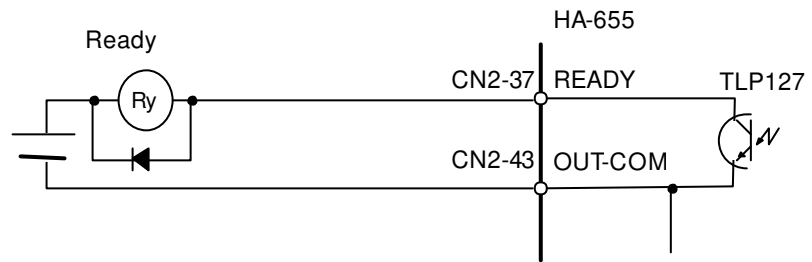

CN2-38 Alarm-A + : A L M –A (output)**CN2-39 Alarm-B + : A L M –B (output)****CN2-40 Alarm-C + : A L M –C (output)****CN2-41 Alarm-D + : A L M –D (output)**

- **Function**

When The HA-655 driver senses an alarm, the 4-bit code corresponding to the alarm, shown in the table below, outputs from the ports.

alarm code	Alarm description	4-bit code	ALM -D	ALM -C	ALM -B	ALM -A	alarm clear
10	Over speed	1011	ON	OFF	ON	ON	Impossible
20	Over load	0001	OFF	OFF	OFF	ON	Possible
21	Overheat	1000	ON	OFF	OFF	OFF	Impossible
30	Over current	1001	ON	OFF	OFF	ON	Impossible
41	Abnormal regeneration	1010	ON	OFF	ON	OFF	Impossible
50	Encoder failure	1101	ON	ON	OFF	ON	Impossible
51	Abnormal encoder signal	1101	ON	ON	OFF	ON	Impossible
52	UVW failure	1101	ON	ON	OFF	ON	Impossible
53	*ABS system failure	1101	ON	ON	OFF	ON	Impossible
54	*ABS MTD over flow	1101	ON	ON	OFF	ON	Impossible
55	*ABS multi-turn data error	1101	ON	ON	OFF	ON	Impossible
56	*ABS low battery voltage	1101	ON	ON	OFF	ON	Impossible
57	*ABS send data rule error	1101	ON	ON	OFF	ON	Impossible
60	Error counter overflow	0010	OFF	OFF	ON	OFF	Possible
70	Memory failure (RAM)	0101	OFF	ON	OFF	ON	Impossible
71	Memory failure (EEPROM)	0101	OFF	ON	OFF	ON	Impossible
76	CPU failure	0100	OFF	ON	OFF	OFF	Impossible

Notice: the alarm codes 53 through 57 are valid for absolute encoders only.

CN2-42 Phase-Z (OC): Z (output)

- **Function**

The port outputs phase-Z pulse signal of the encoder. The signal is outputted one pulse per every one motor rotation. The signal may be used with the mechanical origin signal as a precise origin of the driven mechanism.

- **Connection**

- (1) An example of [CN2-42 phase-Z: Z] connection is shown in the figure to the right.
- (2) The port is opto-isolated.
- (3) Plan the output circuit for the ports as follows:
Supply voltage: DC24V or less
Signal current: 40mA or less

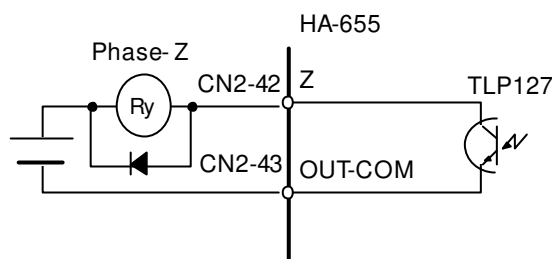
**CN2-43 Output common: OUT-COM (output)**

- **Function**

This is the common port for the [CN2-33, 34, 38, 39, 40, 41, 42] ports.

CN2-44 Phase-A + (LD): A+ (output)**CN2-45 Phase-A- (LD): A- (output)****CN2-46 Phase-B + (LD): B+ (output)****CN2-47 Phase-B- (LD): B- (output)****CN2-48 Phase-Z + (LD): Z+ (output)****CN2-49 Phase-Z- (LD): Z- (output)**

- **Function**

These ports transmit encoder signals of Phase-A, -B, -Z through the line driver (26LS31).

- **Connection**

Receive the signals using a line receiver (AM26LS32 or equivalent).

Notice: the alarm codes 53 through 57 are valid for absolute encoders only.

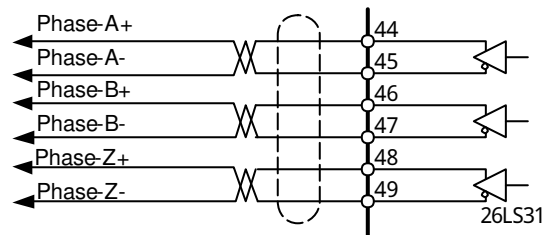
**CN2-50 Ground: FG (output)**

- **Function**

Connect shield of cable.

3-1-5 Connection examples in the position mode

<< for incremental encoder system >>

- The figure below shows a connection example in the position mode for [open collector] signals. The command configuration is [2-pulse] type.

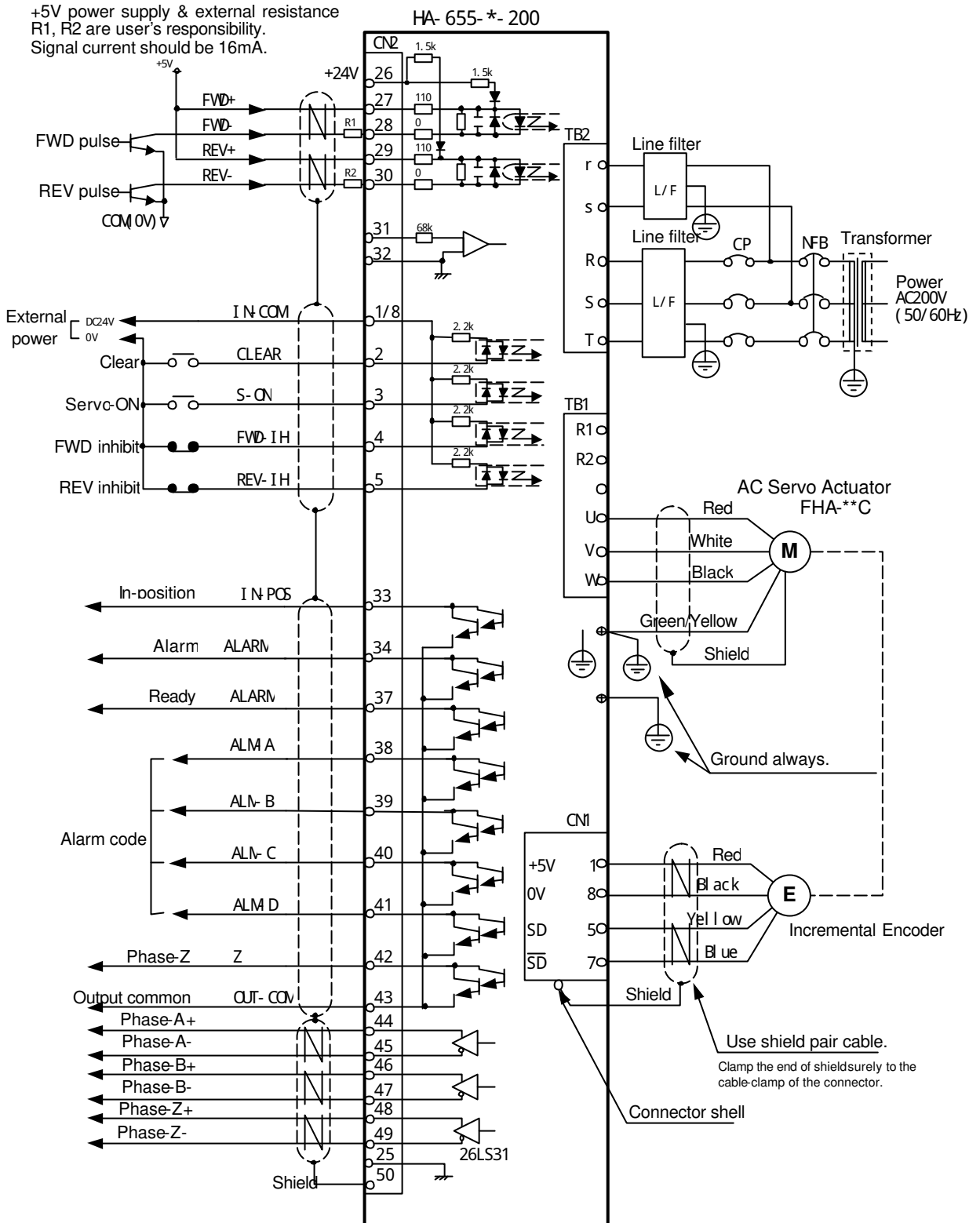

- The figure below shows a connection example in the position mode for [line driver] signals. The command configuration is [2-pulse] type.

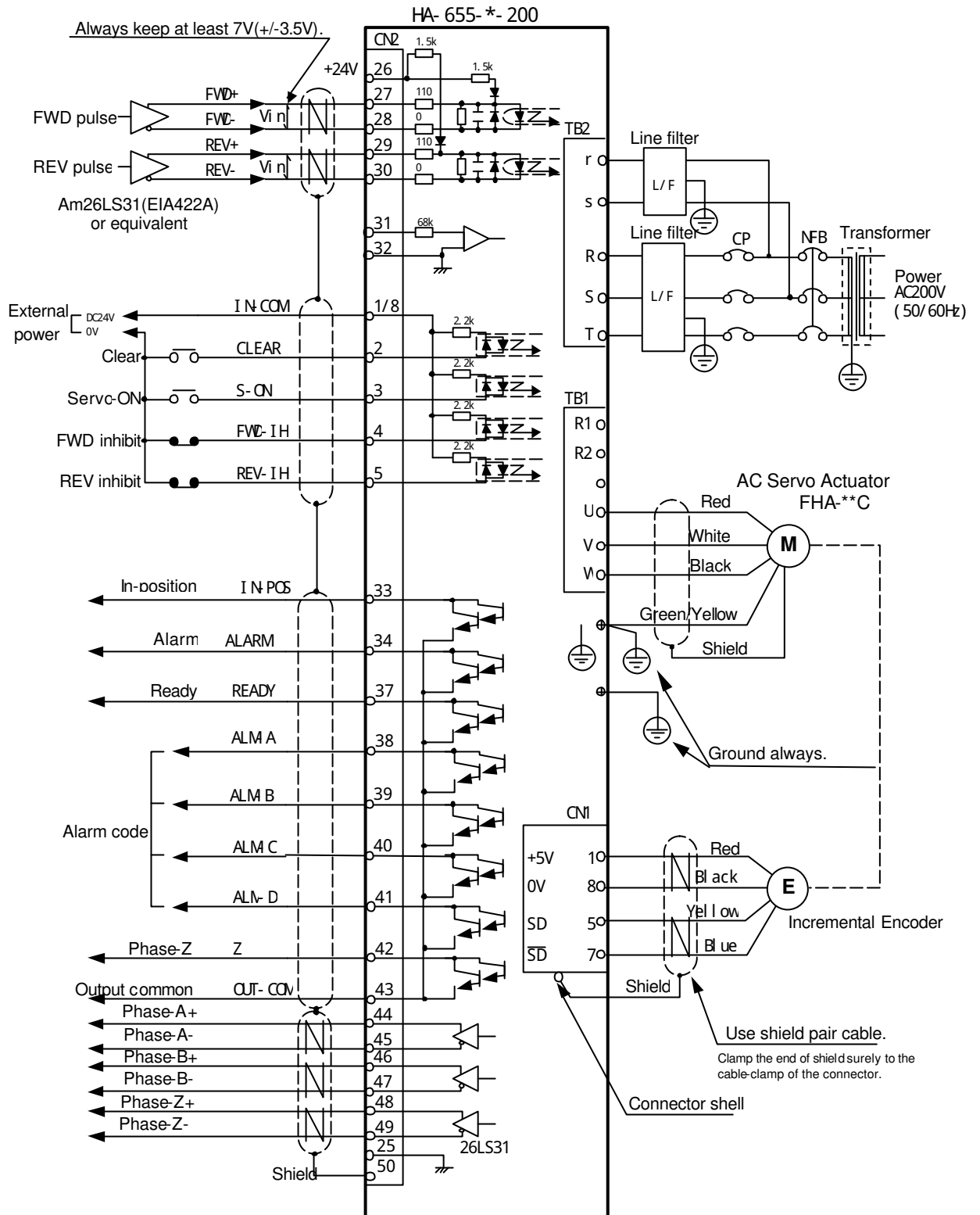

<< for absolute encoder system >>

- The figure below shows a connection example in the position mode for [open collector] signals. The command configuration is [2-pulse] type.

+5V power supply & external resistance R1, R2 are user's responsibility.
Signal current should be 16mA.

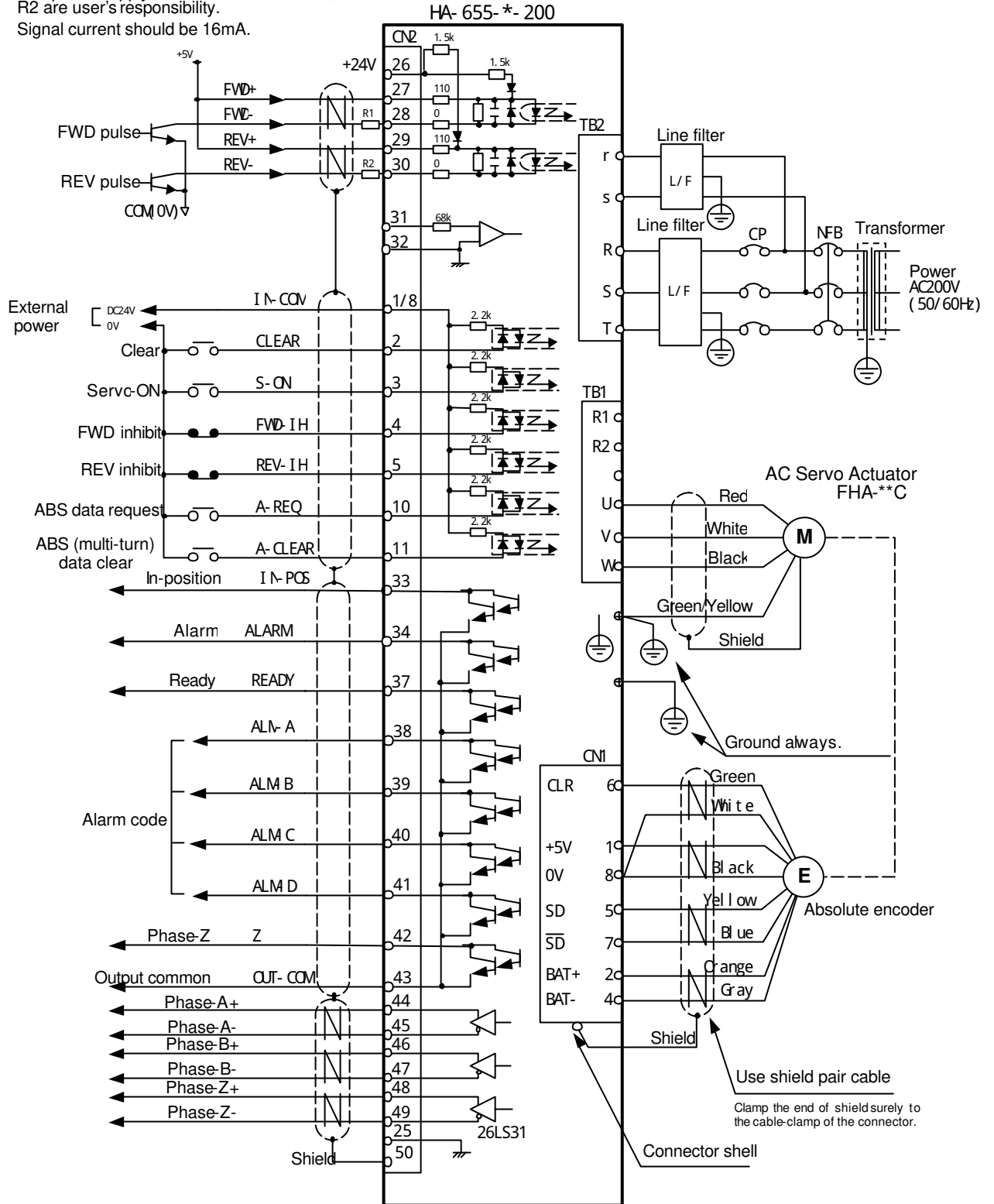

- The figure below shows a connection example in the position mode for [line driver] signals. The command configuration is [2-pulse] type.

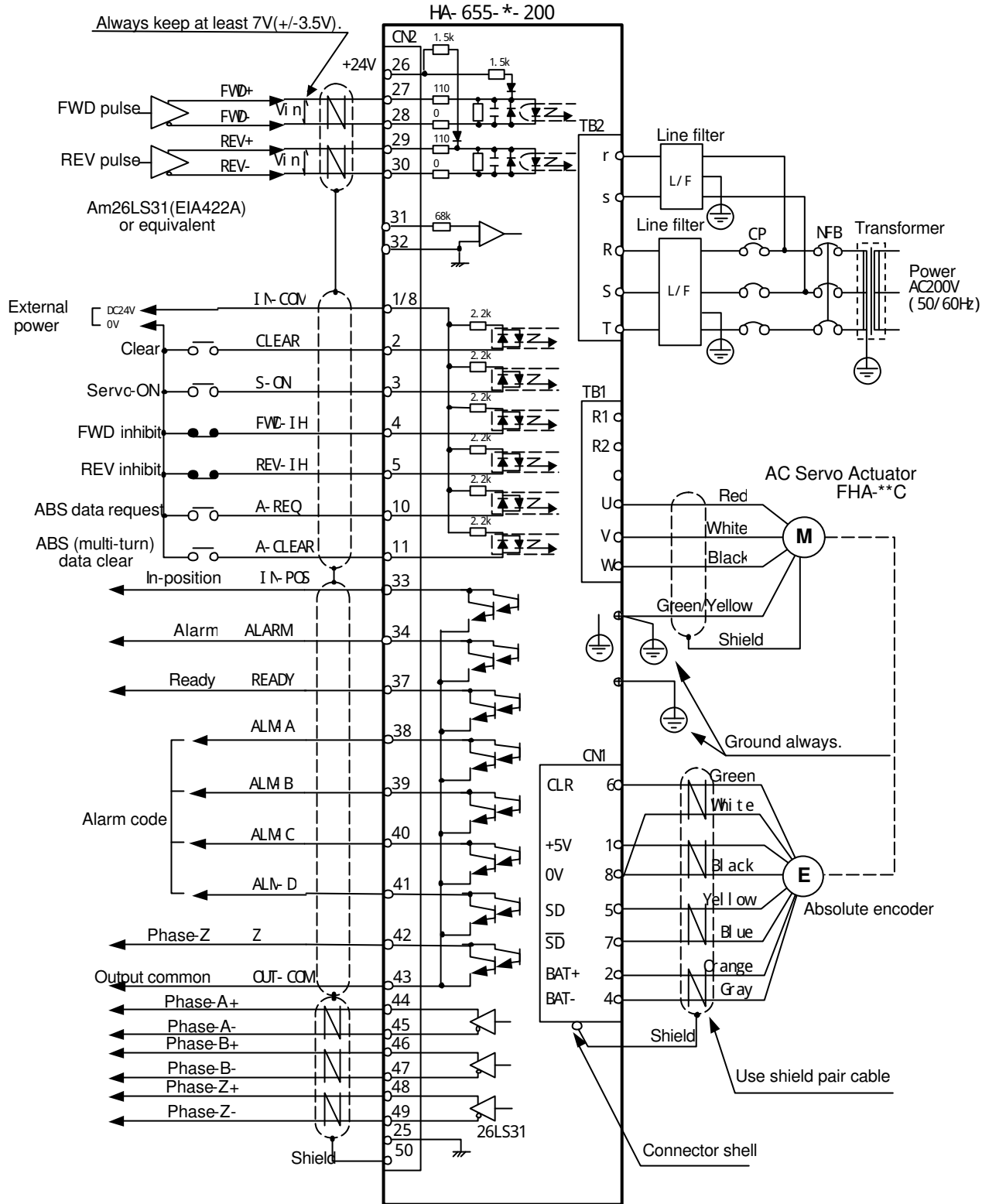

3-2 Speed mode

3-2-1 I/O port layout

<< for incremental encoder system >>

The I/O port layout is shown as follows:

※ Do not use the pins marked “-”.

Pin	Signal name	Symbol	I/O
1	Input signal common	IN-COM	Input
2	Clear	CLEAR	Input
3	Servo-ON	S-ON	Input
4	FWD enable	FWD-EN	Input
5	REV enable	REV-EN	Input
6	Command change	CMD-CHG	Input
7	-	-	NC
8	Input signal common	IN-COM	Input
9	-	-	-
10	-	-	-
11	-	-	-
12	-	-	-
13	-	-	-
14	-	-	-
15	-	-	-
16	-	-	-
17	-	-	-
18	-	-	-
19	-	-	-
20	-	-	-
21	-	-	-
22	-	-	-
23	Speed monitor	SPD-MON	Output
24	Current monitor	CUR-MON	Output
25	Monitor ground	GND	Output

Pin	Signal name	Symbol	I/O
26	-	-	-
27	-	-	-
28	-	-	-
29	-	-	-
30	-	-	-
31	Speed command	SPD-CMD	Input
32	Speed command ground	SG-GND	Input
33	Attained speed	HI-SPD	Output
34	Alarm	ALARM	Output
35	Ready	READY	Output
36	-	-	-
37	-	-	-
38	Alarm-A+	ALM-A	Output
39	Alarm-B+	ALM-B	Output
40	Alarm-C+	ALM-C	Output
41	Alarm-D+	ALM-D	Output
42	Phase-Z (OC)	Z	Output
43	Output common	OUT-COM	Output
44	Phase-A+ (LD)	A+	Output
45	Phase-A- (LD)	A-	Output
46	Phase-B+ (LD)	B+	Output
47	Phase-B- (LD)	B-	Output
48	Phase-Z+ (LD)	Z+	Output
49	Phase-Z- (LD)	Z-	Output
50	Frame ground	FG	Output

Note: OC: open collector, LD: line driver

<< for absolute encoder system >>

The I/O port layout is shown as follows:

※ Do not use the pins marked “-”.

Pin	Signal name	Symbol	I/O
1	Input signal common	IN-COM	Input
2	Clear	CLEAR	Input
3	Servo-ON	S-ON	Input
4	FWD enable	FWD-EN	Input
5	REV enable	REV-EN	Input
6	Command change	CMD-CHG	Input
7	-	-	NC
8	Input signal common	IN-COM	Input
9	-	-	-
1 0	ABS data request	ABS-REQ	Input
1 1	ABS (multi-turn) data clear	ABS-CLEAR	Input
1 2	-	-	-
1 3	-	-	-
1 4	-	-	-
1 5	-	-	-
1 6	-	-	-
1 7	-	-	-
1 8	-	-	-
1 9	-	-	-
2 0	-	-	-
2 1	-	-	-
2 2	-	-	-
2 3	Speed monitor	SPD-MON	Output
2 4	Current monitor	CUR-MON	Output
2 5	Monitor ground	GND	Output

Pin	Signal name	Symbol	I/O
2 6	-	-	-
2 7	-	-	-
2 8	-	-	-
2 9	-	-	-
3 0	-	-	-
3 1	Speed command	SPD-CMD	Input
3 2	Speed command ground	SG-GND	Input
3 3	Attained speed	HI-SPD	Output
3 4	Alarm	ALARM	Output
3 5	-	-	-
3 6	-	-	-
3 7	Ready	READY	Output
3 8	Alarm-A +	ALM-A	Output
3 9	Alarm-B +	ALM-B	Output
4 0	Alarm-C +	ALM-C	Output
4 1	Alarm-D +	ALM-D	Output
4 2	Phase-Z (OC)	Z	Output
4 3	Output common	OUT-COM	Output
4 4	Phase-A + (LD)	A+	Output
4 5	Phase-A- (LD)	A-	Output
4 6	Phase-B + (LD)	B+	Output
4 7	Phase-B- (LD)	B-	Output
4 8	Phase-Z + (LD)	Z+	Output
4 9	Phase-Z- (LD)	Z-	Output
5 0	Frame ground	FG	Output

Note: OC: open collector, LD: line driver

3-2-2 Models of I/O port connector CN2

The models of the CN2 connector are as follows:

Connector:	10150-3000VE	3M
Cover:	10350-52F0-008	3M

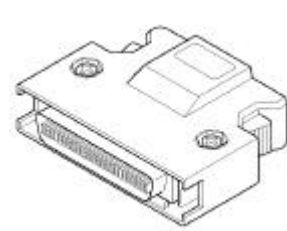

3-2-3 I/O port connections in the speed mode

This section describes the connections between the I/O ports and the host in the speed mode.

Inputs:

The HA-655 driver provides six ports for inputs as shown in the figure to the right.

◆ **Specifications**

Voltage: DC24V ± 10%
 Current: 20mA or less
 (for each terminal)

An input port circuit is shown in the figure to the right. The ports marked with (*) are available for absolute encoder system only.

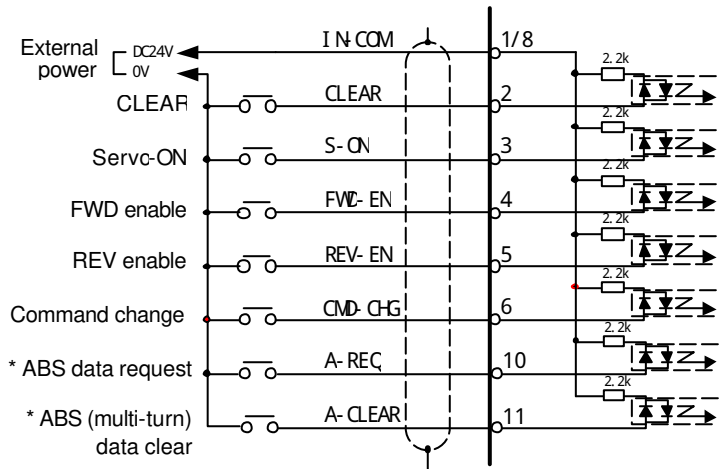

• **Connection**

The HA-655 driver does not provide the power supply for input signals. A [+24V] power supply for the signals to [CN2-1: input signal common].

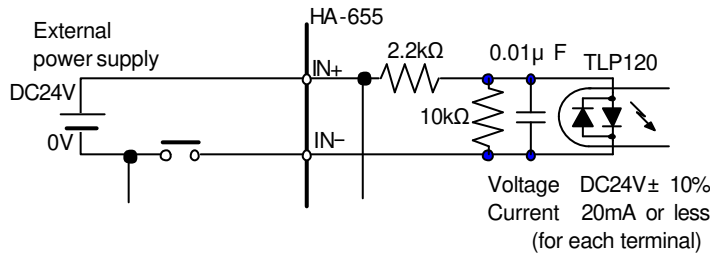

Outputs

The HA-655 driver provides eight ports for outputs as shown in the figure to the right.

◆ **Specifications**

Port: Open collector
 Voltage: DC24V or less
 Current: 40mA or less
 (for each port)

All ports are insulated by opto-isolators.

An output circuit is shown in the figure to the right.

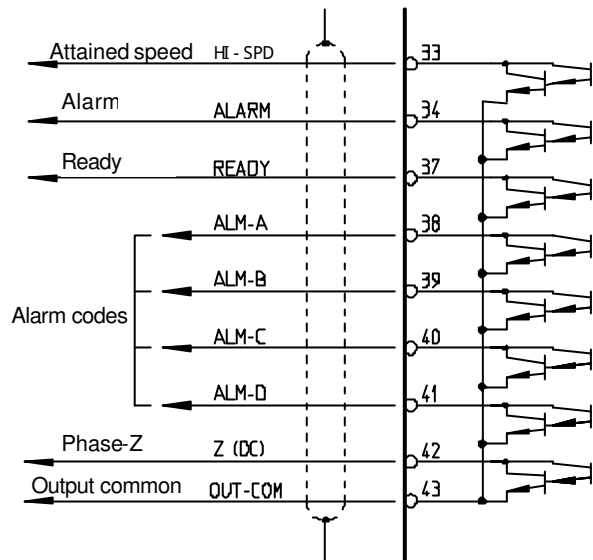

• **Connection**

Connect output signals between their respective output ports and [CN2-43: output common] port.

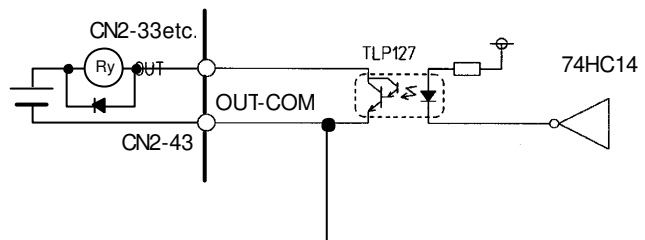

3-2-4 I/O port functions in the speed mode

This section describes I/O port functions in the speed mode.

CN2-1 Input signal common: IN-COM (input)

- **Function**

This is the common port for inputs: [CN2-2, -3, -4, -5, -6, -10, -11]. Supply external power for inputs from this port.

- **Connection**

Connect [+24V] external power supply for inputs here.

CN2-2 Clear: CLEAR (input)

- **Function**

(3) If an alarm exists:

This clears the alarm state, returns to operable state, and clears the error count to [0]. For alarms that cannot be cleared, shut off the control power once, and turn it on again.

(4) If no alarm exists:

This clears the error count to [0].

- **Connection**

Connect [NO-contact signal (a-contact)].

Refer to [CN2-1: input signal common].

CN2-3 Servo-ON: S-ON (input)

- **Function**

This turns the servo power for the HA-655 driver ON and OFF.

When the input is ON, the servo power of the HA-655 driver is ON and the actuator can be driven. When OFF, the servo power turns OFF and the motor is free to rotate.

- **Connection**

Connect [NO-contact signal (a-contact)].

Refer to [CN2-1: input signal common].

CN2-4 FWD enable: FWD-EN (input)**CN2-5 REV enable: REV-EN (input)**

- **Function**

While the [FWD enable] is [ON] the actuator rotates forward when the [CN2-31 speed command: SPD-CMD] is [+]. In contrast, the actuator rotates in reverse for the [CN2-31] is [-].

While the [REV enable] is [ON] the actuator rotates in reverse when the [CN2-31 speed command: SPD-CMD] is [+]. Conversely, the actuator rotates forward when the [CN2-31] is [-].

When both signals of [FWD enable] and [REV enable] are [ON] or [OFF], the actuator is holding the position or zero speed depending on the setting of [parameter mode] → [7: zero clamp].

CN2-31 Speed cmd.: SPD-CMD		+ Command		- Command	
CN2-4 FWD enable: FWD-EN		ON	OFF	ON	OFF
CN2-5 REV enable: REV-EN	ON	Zero clamp, zero speed	REV rotation	Zero clamp, zero speed	FWD rotation
	OFF	FWD rotation	Zero clamp, zero speed	REV rotation	Zero clamp, zero speed

- **Connection**

Refer to [CN2-1: input signal common].



Servo-free state occurs at alarm occurrences during no power supply for the main circuit or the control circuit, or no servo-ON signal. If large unbalanced load is applied to actuators, the servo-free state may cause physical injury.

CN2-6 Command change: CMD-CHG(input)

- **Function**

The function can operate the actuator without a command signal at the speed specified by [tune mode] → [6: internal speed command].

OFF: command speed

ON: internal speed

- **Connection**

Refer to [CN2-1: input signal common].

CN2-8 Input common: IN-COM(input)

- **Function**

The same functions as CN2-1

CN2-10 absolute data request: ABS-REQ(input) *absolute encoder system only

Function

The input is used for a command to output a current resolving count of the encoder.

CN2-11 ABS (multi-turn) data clear: ABS-CLEAR(input) *absolute encoder system only

Function

The input uses for a command to clear a current resolving count of the multi-turn counter to zero.

CN2-23 Speed monitor: SPD-MON (output)

• **Function**

The port outputs a voltage signal proportional to the motor speed. The actual motor speed is obtained by the following formula:

$$\text{Motor speed} = \text{Command voltage} \times \frac{\text{Speed conversion factor}}{10.0\text{V}}$$

◆ Specifications of output:

Voltage range: -15V to +15V
Output impedance: 1kΩ

• **Connection**

Connect the monitor to the [CN2-23: speed monitor: SPD-MON] and the [CN2-25: GND].

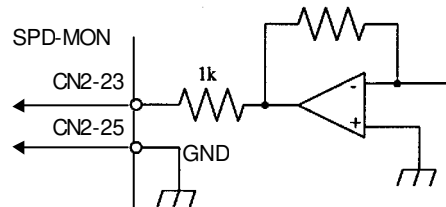

CN2-24 Current monitor: CUR-MON (output)

• **Function**

The port outputs a voltage signal proportional to the motor current. The relation between the voltage and the current is set so that the monitor voltage of [+10V] corresponds to the actuator maximum current.

$$\text{Monitor voltage(V)} = \text{Actuator current} \times \frac{10}{\text{Actuator maximum current}}$$

◆ Specifications of output:

Voltage range: -15V to +15V
Output impedance: 1kΩ

• **Connection**

Connect the monitor to the [CN2-24: current monitor: CUR-MON] and the [CN2-25: GND].

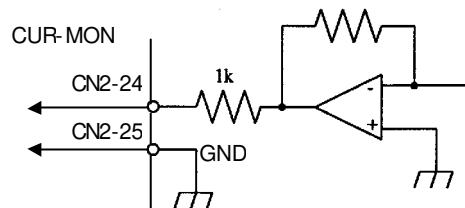

CN2-31 Speed command: SPD-CMD(input)

• **Function**

Input the speed command voltage signal which is obtained by [parameter mode] → [9: speed conversion factor].

$$\text{Motor speed} = \text{Speed command voltage} \times \frac{\text{Speed conversion factor} V}{10.0}$$

The direction of rotation is specified by the polarity (+/-) of the speed command and input signals of [CN2-4 FWD enable: FWD-EN] and [CN2-5 REV enable: REV-EN].

While the [FWD enable]: is ON the actuator rotates forward when the [CN2-31 Speed command: SPD-CMD] is [+]. In contrast, the actuator rotates in reverse for the [CN2-31] is [-].

While the [REV enable]: is ON the actuator rotates in reverse the [CN2-31 Speed command: SPD-CMD] is [+]. In contrast, the actuator rotates forward when the [CN2-31] is [-].

When both signals [FWD enable] and [REV enable] are ON or OFF, depending on the setting of [parameter mode] → [7: zero clamp], the actuator is either holding the position (setting:1) or zero speed (setting: 0).

CN2-31 Speed cmd.: SPD-CMD		+ Command		- Command	
CN2-4 FWD enable: FWD-EN		ON	OFF	ON	OFF
CN2-5 REV enable: REV-EN	ON	Zero clamp, zero speed	REV rotation	Zero clamp, zero speed	FWD rotation
	OFF	FWD rotation	Zero clamp, zero speed	REV rotation	Zero clamp, zero speed

• **Connection**

Connect the voltage signal to the [CN2-31: speed command: SPD-COM] and the [CN2-32: SG-GND].

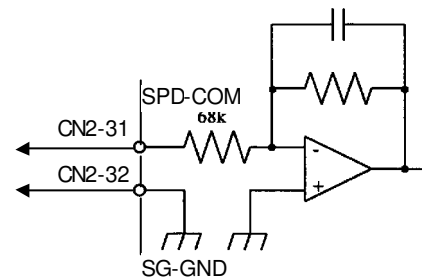

Plan the command circuit referring to the examples below.

◆ **By a potentiometer**

- R: 1/2W 330Ω
- VR: 25HP-1; 2kΩ by Sakae
- Multi-turn wire-wound potentiometer

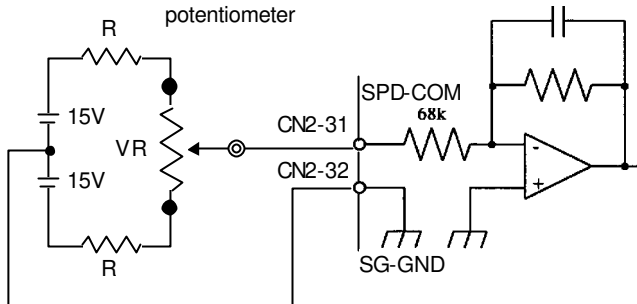

◆ **By host command**

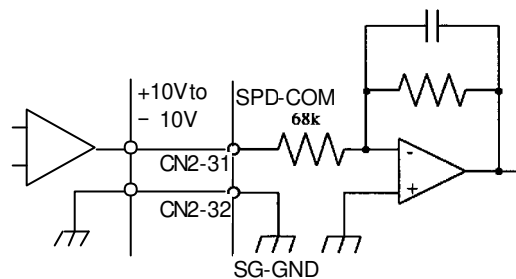

CN2-32 Speed command common: SG-GND(input)

• **Function**

The port is the common ground for the [CN2-31 speed command: SPD-CMD].

CN2-33 Attained speed: HI-SPD (output)

- **Function**

The output turns ON when the motor rotates at a speed greater than the value of [tune mode] → [5: attained speed].

- **Connection**

(1) The figure to the right shows an example of the [CN2-33 attained speed: HI-SPD] port connection.

(2) Plan the output circuit for the ports as follows:
 Supply voltage: DC24V or less
 Signal current: 50mA or less
 (for each port)

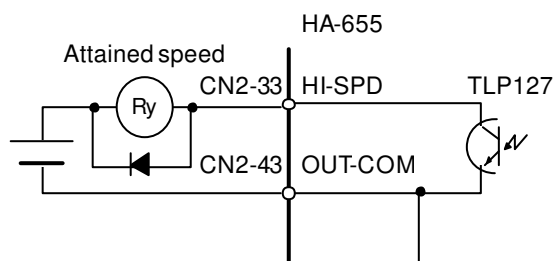
**CN2-34 Alarm: ALARM (output)**

- **Function**

The output turns OFF when the HA-655 driver senses an alarm.

- **Connection**

(1) An example of [CN2-34 alarm: ALARM] connection is shown in the figure below.

(2) Plan the output circuit for the ports as follows:

Supply voltage: DC24V or less
 Signal current: 50mA or less

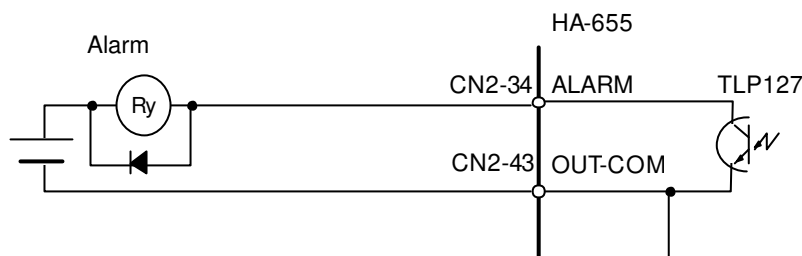
**CN2-37 Ready: READY (output)**

- **Function**

The output turns ON when the HA-655 driver is ready to drive.

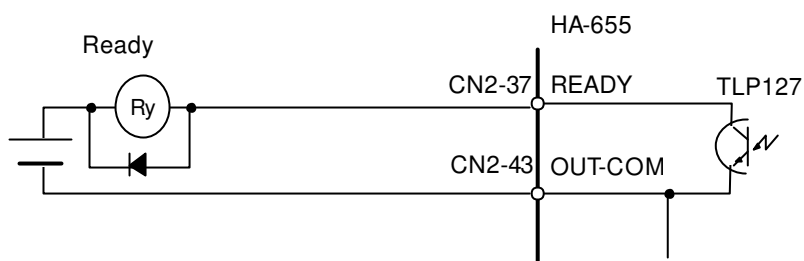

CN2-38 Alarm-A + : A L M –A (output)**CN2-39 Alarm-B + : A L M –B (output)****CN2-40 Alarm-C + : A L M –C (output)****CN2-41 Alarm-D + : A L M –D (output)**

- **Function**

When the HA-655 driver senses an alarm, the 4-bit code corresponding to the alarm, shown in the table below, outputs from the ports.

alarm code	Alarm description	4-bit code	ALM -D	ALM -C	ALM -B	ALM -A	alarm clear
10	Over speed	1011	ON	OFF	ON	ON	Impossible
20	Over load	0001	OFF	OFF	OFF	ON	Possible
21	Overheat	1000	ON	OFF	OFF	OFF	Impossible
30	Over current	1001	ON	OFF	OFF	ON	Impossible
41	Abnormal regeneration	1010	ON	OFF	ON	OFF	Impossible
50	Encoder failure	1101	ON	ON	OFF	ON	Impossible
51	Abnormal encoder signal	1101	ON	ON	OFF	ON	Impossible
52	UVW failure	1101	ON	ON	OFF	ON	Impossible
53	*ABS system failure	1101	ON	ON	OFF	ON	Impossible
54	*ABS MTD over flow	1101	ON	ON	OFF	ON	Impossible
55	*ABS multi-turn data error	1101	ON	ON	OFF	ON	Impossible
56	*ABS low battery voltage	1101	ON	ON	OFF	ON	Impossible
57	*ABS send data rule error	1101	ON	ON	OFF	ON	Impossible
60	Error counter overflow	0010	OFF	OFF	ON	OFF	Possible
70	Memory failure (RAM)	0101	OFF	ON	OFF	ON	Impossible
71	Memory failure (EEPROM)	0101	OFF	ON	OFF	ON	Impossible
76	CPU failure	0100	OFF	ON	OFF	OFF	Impossible

Notice: the alarm codes 53 through 57 are valid for absolute encoders only.

CN2-42 Phase-Z (OC): Z (output)

- **Function**

The port outputs a phase-Z pulse signal of the encoder. The signal is outputted one pulse per every one motor rotation. The signal may be used with the mechanical origin signal as a precise origin of the driven mechanism.

- **Connection**

(1) An example of [CN2-42 phase-Z: Z] connection is shown in the figure below.

(2) The port is opto-isolated.

(3) Plan the output circuit for the ports as follows:
 Supply voltage: DC24V or less
 Signal current: 50mA or less

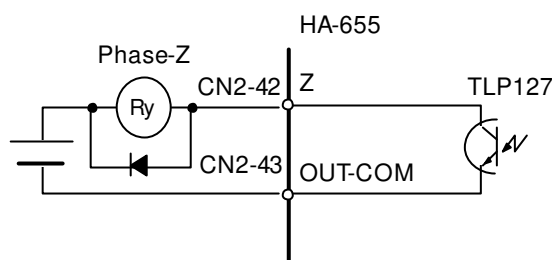
**CN2-43 Output common: OUT-COM (output)**

- **Function**

This is the common port for the [CN2-33, 34, 37, 38, 39, 40, 41, 42] ports.

CN2-44 Phase-A + (LD): A+ (output)**CN2-45 Phase-A- (LD): A- (output)****CN2-46 Phase-B + (LD): B+ (output)****CN2-47 Phase-B- (LD): B- (output)****CN2-48 Phase-Z + (LD): Z+ (output)****CN2-49 Phase-Z- (LD): Z- (output)**

- **Function**

These ports transmit encoder signals of Phase-A, -B, -Z from the line driver (26LS31).

- **Connection**

Receive the signals by using line receiver (AM26LS32 or equivalent).

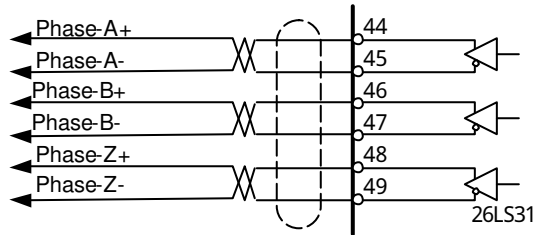
**CN2-50 Ground: FG (output)**

- **Function**

Connect shield of the cable.

3-2-5 Connection examples in the speed mode

<< for incremental encoder system >>

- The figure below shows a connection example in the speed mode for an incremental encoder system.

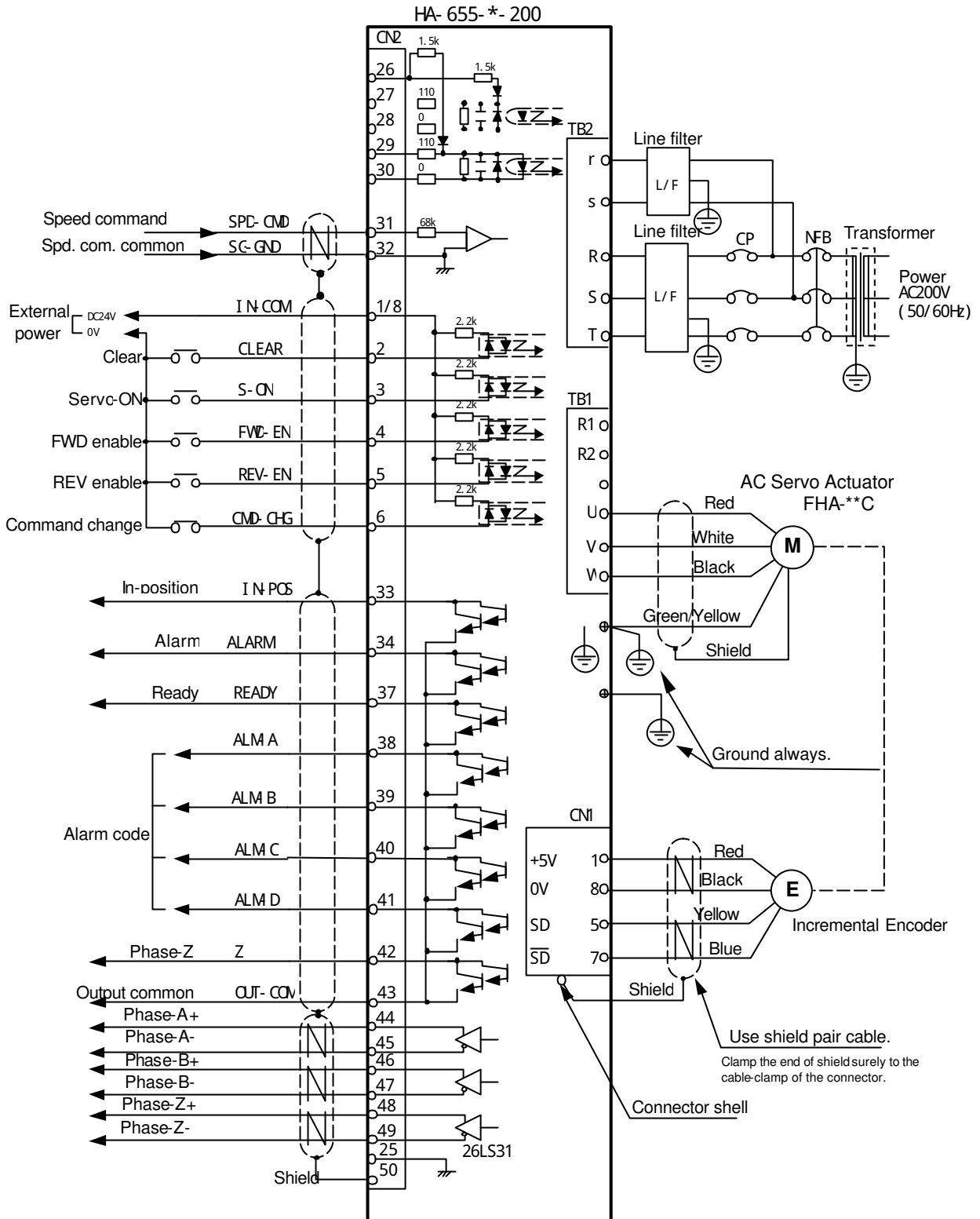

<< for absolute encoder system >>

- The figure below shows a connection example in the speed for an absolute encoder system..

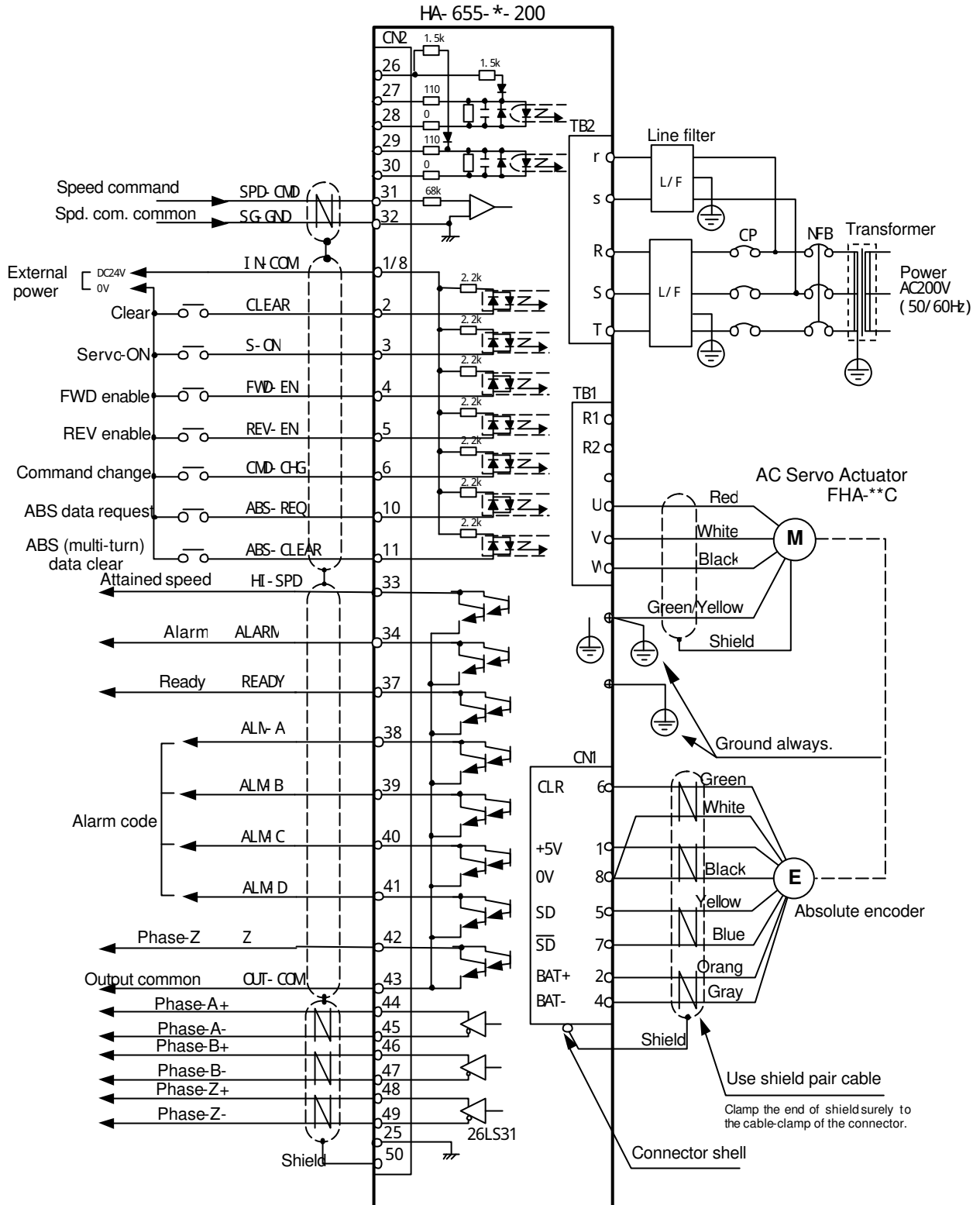

Chapter 4 Installing HA-655 driver

4-1 Receiving Inspection

Check the followings when products are received.

- **Inspection procedure**

- (1) Check the shipping container and item for any damage that may have been caused during transportation. If the item is damaged, immediately contact the dealer it was purchased from.
- (2) The label, shown in the figure to the right, is attached on the right side of the HA-655 driver. Confirm the products you ordered by comparing with the model on the [POWER] line of the label. If it is different, immediately contact the dealer it was purchased from.

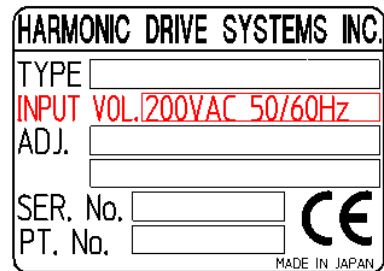

The model code is interpreted as follows:

HA-655-2A-200

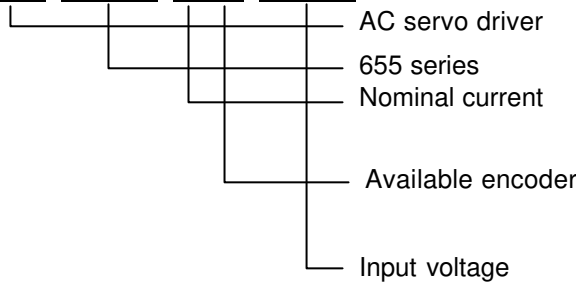

2	2.4A
4	4.0A

void	incremental encoder model
A	absolute encoder model

200	AC200V
100	AC100V

- (3) Under the [ADJ.] line, the code of the FHA-C series actuator to be driven by the HA-655 driver is typed. To avoid confusion, group the actuator with its appropriate driver.



Only connect the actuator specified on the driver label.

The HA-655 driver has been tuned for the actuator specified on the driver label. The wrong combination of HA-655 drivers and actuators may cause low torque problems or over current that may cause physical injury and fire.

- (4) The input voltage for the HA-655 driver is identified with the last code of the model code in the [TYPE] frame on the label.

200: 3-phase or single-phase 200V

100: single-phase 100V

If the voltage to be supplied is different from the voltage on the label, immediately contact the dealer from who it was purchased.



Do not supply voltage other than the voltage specified on the label.

The wrong power supply voltage may damage the HA-655 driver resulting physical injury and fire.

4-2 Notices on handling

The HA-655 drivers are electronic devices. Handle them with care and take the following precautions:



- (1) Because the case is made of plastic, do not apply excess force or shock.
- (2) The vibration resistance of the HA-655 driver is 4.9m/s^2 (10 to 55Hz). Do not mount or transport the HA-655 driver in a manner where it would be subjected to high levels of vibration.
- (3) Do not put the HA-655 driver on the place from where it can easily fall down.
- (4) Do not put anything on the HA-655 driver. The case of the driver may break.
- (5) Do not drop screws, solder balls, wire chips, or any other foreign objects through the ventilation gaps of the HA-655 driver.
- (6) Do not insert electric wire, steel wire, or a screwdriver through the ventilation gaps of the HA-655 driver.
- (7) Handle the terminal cover carefully. Do not use the HA-655 driver without the terminal cover. Failure to observe this caution may result in electric shock or personal injury.
- (8) The allowable storage temperature is from -20°C to $+85^{\circ}\text{C}$. Do not expose it to sunlight for long periods of time, and do not store it in areas where temperatures are likely to fluctuate greatly.
- (9) The allowable storage relative humidity is less than 95%. Do not store it in highly humid place or in areas where temperatures are likely to fluctuate greatly.
- (10) Do not store the HA-655 driver in areas where in corrosive gas or particles may be present.

4-3 Location and installation

4-3-1 Environment of location

The environmental conditions of the location are as follows:

- ◆ Service temperature: 0°C to 50°C
Use the driver in a cabinet. The temperature in the cabinet may be higher than the atmosphere because of power loss of the housed devices and its size. Plan the cabinet size, ventilation system, and device locations so the ambient temperature of the driver, which is always less than 50°C.
- ◆ Service humidity: less than 95% relative humidity, without condensation
Make sure that water condensation does not occur due to fluctuating temperatures in the storage area or because of frequent heat-and-cool (run-and-stop) operations.
- ◆ Vibration: less than 4.9m/sec^2 (0.5G) (10Hz to 55Hz)
When there is a great deal of vibration near the driver, attach a shock absorber under the base to dampen the vibration.
- ◆ Impact: less than 98m/s^2 (10G)
- ◆ Make sure that dust, water condensation, metal powder, corrosive gas, water, water drops, or oil mist is not exposed to the HA-655 driver.
Do not install the driver in a corrosive gas environment, because the gas may cause damage to connecting parts (connectors, etc.).
- ◆ Install the driver in a cabinet. Do not expose it to the sunlight.

4-3-2 Notices on installation

Install the driver vertically and allow for wide spaces for air to flow sufficiently.

Leave 30mm or more from walls, 50mm or more from floor and 100mm from ceiling, and adjacent devices as shown the figure below.

When planning the ventilation system for the cabinet refer to the table below, which lists the power consumption of the HA-655 driver.

Driver	HA-655-2		HA-655-4	
Actuator	FHA-17C	FHA-25C	FHA-32C	FHA-40C
Power consumption	30W	40W	50W	60W

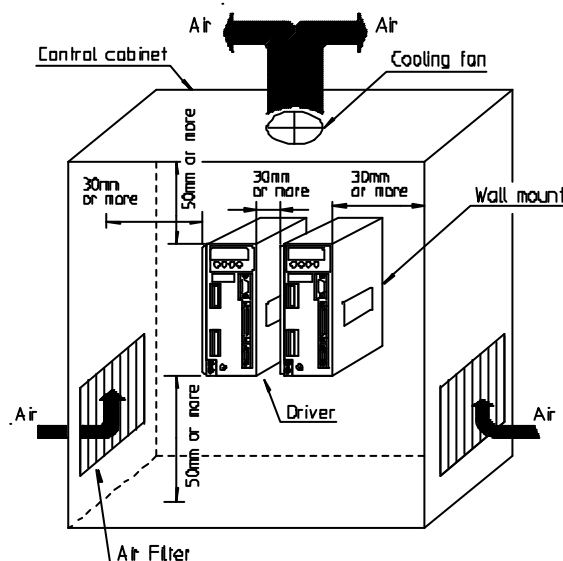

4-3-3 Installing

The HA-655 driver should be mounted on a wall as shown in the figure to the right.

Two mounting holes are provided on the back of the driver. The thickness of the wall should be more than 2mm.

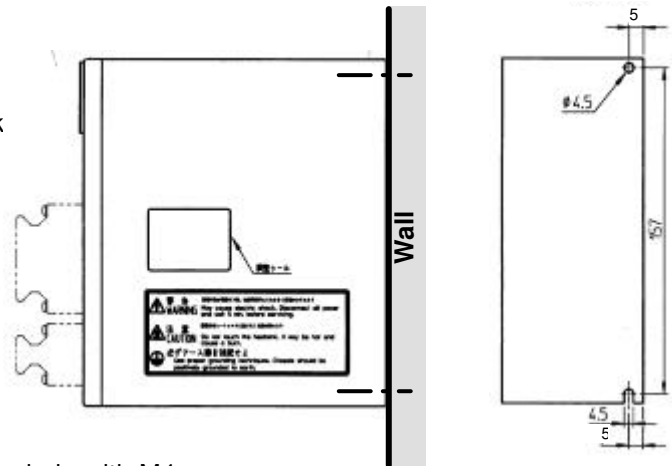

- **Procedure**

- (1) Screw an M4 machine screw in the tapped hole on the wall.
- (2) Put the lower mounting hole (cut hole) of the back of the driver on the M4 screw.
- (3) Screw tightly through the upper mounting hole with M4 screws.
- (4) Tighten the lower M4 screw.

4-4 Suppressing noise

The HA-655 driver employs an IPM (power module) with a PWM control for main circuit. As the IPM generates switching noise by high-speed power switching, the noise may cause incorrect motion of other equipment or radio noise interference due to poor cabling or poor grounding.

In addition, it is necessary to provide proper cable management in order to suppress incorrect motion of the HA-655 driver by external noise from hosts, which contain electronic components, such as a CPU.

To prevent troubles by noise emissions always install cabling and grounding as follows:

4-4-1 Devices for grounding

Refer to the figure below when grounding all devices of the system.

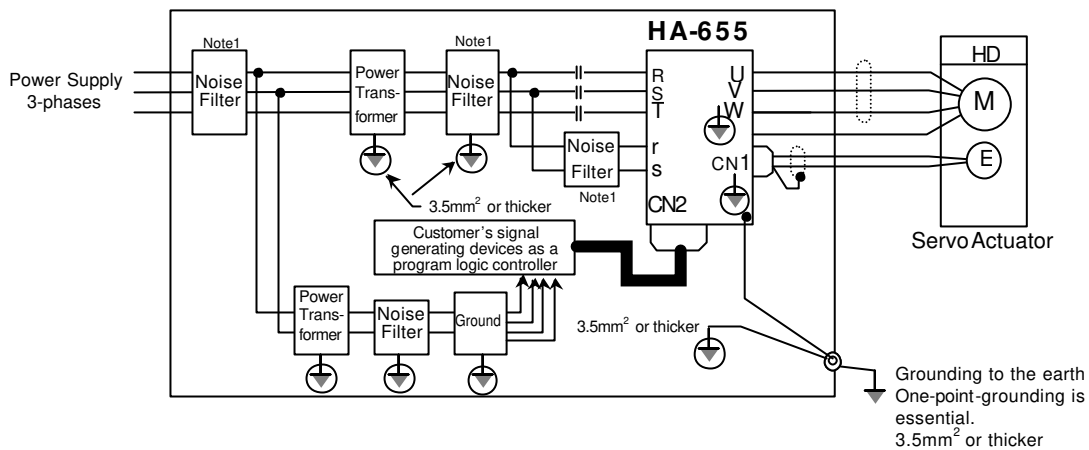

Note 1: For the grounding line filters refer to [4-4-2 installing noise filter].

◆ **Grounding motor frame**

When actuators are grounded at driven machine through the motor frame, current flows through floating capacity (Cf) of the motor from power amplifier of the driver. To avoid influence of the current, always connect the ground terminal (motor frame) of the motor to the ground terminal of the driver, and connect the ground terminal of the driver to the ground directly.

◆ **Grounding ducts**

When the motor cables are housed in a metal conduit or a metal box, ground their metal parts. The ground should be connected to earth at a single point.

4-4-2 Installing noise filters

Noise filters are recommended to guard against incorrect motion caused by impulse noise that may be emitted from power line and to suppress noise emissions to the line from inside of the driver.

When several drivers are used, install noise filters for each driver.

Select bi-directional noise filters that can suppress external and internal noise.

Recommended noise filters are listed in the figure below:

		driver	Model	Ratings	Manufacturer
Main power	Single phase	HA-655-2	SUP-P10H-EPR	250V, 10A	Okaya electric.
		HA-655-4			
	Three phase	HA-655-2	3SUP-H5H-ER-4	250V, 5A	
		HA-655-4	3SUP-H10H-ER-4	250V, 10A	
Control power		All models	SUP-P5H-EPR	250V, 5A	

Install the noise filters and the HA-655 driver as near as possible with one another.

Install the noise filters to the lines of the electric devices other than the HA-655 driver in the same way. Always install the noise filters to the source of high frequency noise, such as electric welders and electrical discharge machines.

Incorrect use of noise filters can seriously reduce its effectiveness. Inspect them with the following instructions:

◆ Separate the filtered side and the unfiltered side of the power supply cables from each other. Do not bundle both together. Do not encase them within the same duct.

◆ Do not bundle the grounding cable with the filtered side of power cables or signal wires. Do not encase them within the same duct.

◆ Avoid daisy-chain wiring of ground cables. Ground them to a frame box or ground plate at a single point.

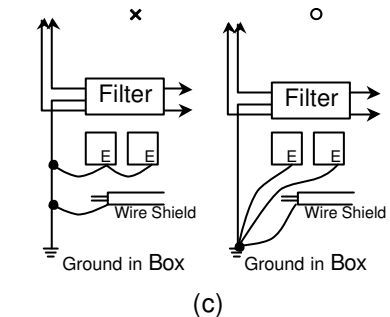
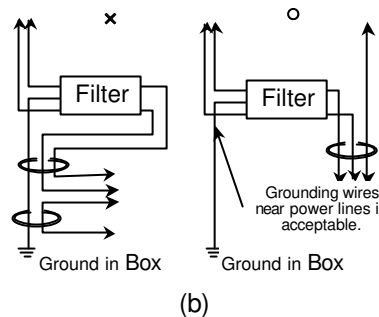
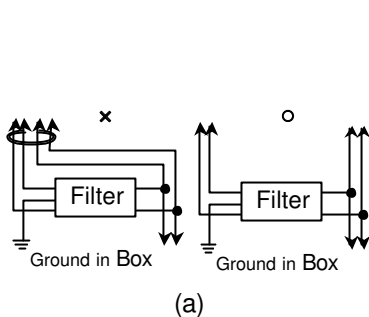

4-4-3 Instructions for cabling

In addition to the noise suppression mentioned previously, one must also follow these instructions:

- (1) Use twisted pair cables for I/O signals, and for encoder signals cables. When a host controls several drivers, prepare I/O signal cables for each driver individually.
- (2) Make the length of signal cables as short as possible.
 - (a) I/O signal cable: 3m or less
 - (b) Encoder signal cable (user's responsibility): 20m or less, providing that the condition of wire conductivity is less than 0.04 ohm/m.Optional cables of 3m/5m/10m long are available.
- (3) Install surge protector devices to magnetic relays coils, magnetic switches, and solenoids.
- (4) Separate power cables (power source cables and motor cables) and I/O signal cables by more than 30cm. Do not encase both cables in one pipe or duct, and do not bundle them.
- (5) Do not open the end of analog signal cables such as speed signal cables.
- (6) As the HA-655 driver is designed for industrial use, it provides no specific radio interference provisions. Accordingly, line filters should be inserted for the power supply cables in the event that the driver:
 - is used in the vicinity of private residences.
 - causes apparent radio interference.

4-5 Connecting power cables

4-5-1 Instructions for power supply



CAUTION

- (1) Before connecting the power cable to the HA-655 driver, turn-OFF the electricity to avoid electric shock.
- (2) Connect the power cable to the HA-655 driver only after installing the driver on a wall.
- (3) Ground the HA-655 driver, to avoid electric shock, malfunctions caused by external noise, and for the suppression of radio noise emissions.

4-5-2 Power cable and ground cable

The minimum allowable wire sizes of power cables, ground wires, and other cables are listed below. We recommend the thickest wires possible.

Terminals and Connectors	Symbol	Allowable Wire Sizes (mm ²)			
		HA-655-2		HA-655-4	
		FHA-17C	FHA-25C	FHA-32C	FHA-40C
Main Power Supply	R,S,T	1.25	1.25	1.25	1.25
Control Power Supply	r, s	1.25	1.25	1.25	1.25
Motor Leads	U,V,W,E	0.75 Note 3	0.75 Note 3	1.25 Note 3	1.25 Note 3
Ground	Ground mark	3.5	3.5	3.5	3.5
Regeneration Resister	R1,R2	0.75	0.75	1.25	1.25
Encoder Port	CN1	0.3mm ² twist pair shielded cable Note 3.			
I/O Signal Port	CN2	0.35mm ² twist pair, or twist pair whole-shielded cable			

Note 1: When bundling wires or encasing into conduits (plastic or metal pipes), use the wire of one size thicker.

Note 2: In hot environments, such as the temperature in a cabinet, use heat-resistant cable (IV or HIV).

Note 3: Optional cables of 3m/5m/10m long are available as follows:

for a motor: EWC-MB -M08-TN

for an incremental encoder: EWC-E -B04-3M14

for an absolute encoder: EWC-S -B08-3M14

└── Cable length

03	3m
05	5m
10	10m

4-5-3 Connecting power cables

The terminal block for the power is located on the front panel of the HA-655 driver. There is no phase order in connection to three-phase power lines.

Shown the figure to the right, strip the end of wires of the power supply cable and the motor cable, and connect wires to each terminal firmly.

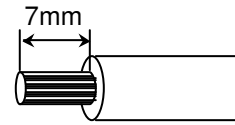

Install an isolation transformer and noise filters in the power lines to avoid electric shock and to guard against malfunctions caused by external noise.

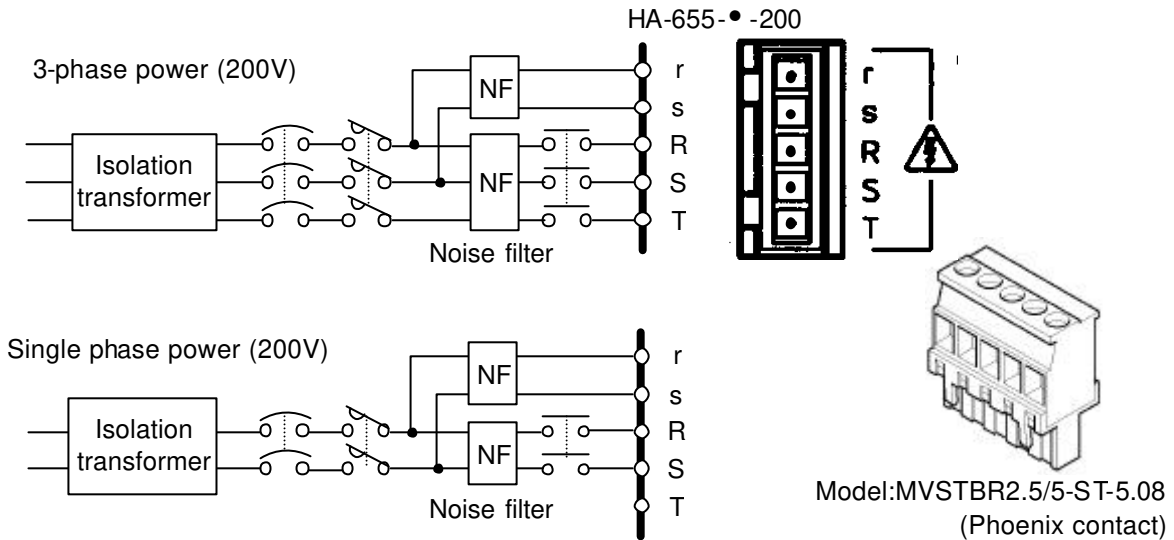

The driver contains a surge-current-suppress-circuit of capacitor type. Although the circuit reduces line voltage fluctuation, avoid daisy-chain wiring of the power lines, and connect units with a main switch.

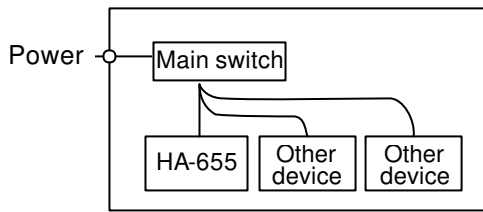

Good connection

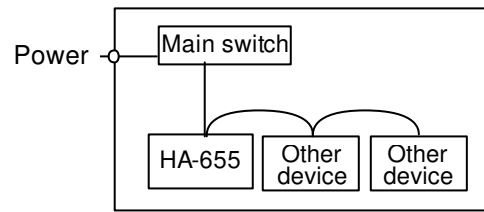

Bad connection

4-5-4 Isolation transformer

The use of an isolation transformer is recommended to prevent problems caused by improper grounding and external noises.

Optional transformers are available as follows:

Unit	Actuator Voltage	FHA-17C	FHA-25C	FHA-32C	FHA-40C
		200V	200V	200V	200V
HA-655-2		PT1-20004			-
HA-655-4				PT1-20008	

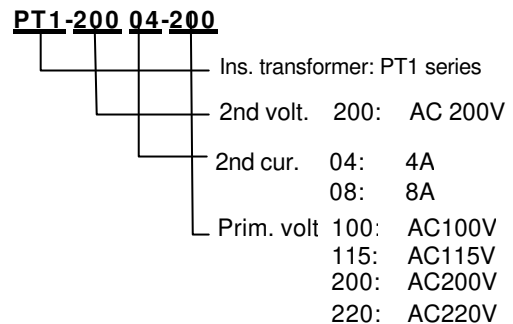

Refer to appendix 1 for the details of the transformers.

4-5-5 Protecting power lines

We recommended protecting the driver by installing a circuit breaker or fuses from surge current at power-ON. Select the recommended circuit breakers or fuses using the table below.

Combinations of actuator and driver		FHA-17C HA-655-2	FHA-25C HA-655-2	FHA-32C HA-655-4	FHA-40C HA-655-4
Interrupting current of MCB or fuse (A)		5	10	15	20
Required capacity per driver (kVA)	Note 1	0.1	0.3	0.5	0.7
Surge current at power ON (A)	Note 2	15	15	15	15

Note 1: The value is for continuous duty at rated output.

Note 2: The values are quoted at ambient temperature of 25 degC.

Note 3: The values are quoted for actuators and drivers for 200V power supply.

4-6 Connecting a ground wire

The minimum allowable size of ground wire is listed in the table below. Use the thickest wire possible.

Terminals and Connectors	Symbol	Allowable Wire Sizes (mm ²)			
		HA-655-2		HA-655-4	
		FHA-17C	FHA-25C	FHA-32C	FHA-40C
Ground(PE)	Ground mark	3.5	3.5	3.5	3.5

The HA-655 driver provides two ground terminals as shown the figure to the right. Connect the ground wire from the cabinet to either terminal and connect the ground wire from the actuator to the other terminal.

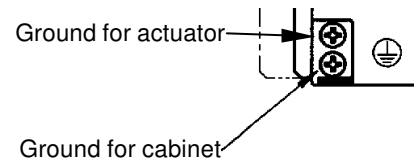

The leakage current is at least 3.5 mA. Therefore terminals must have a section of at least 3.5 mm² and be wired using ring terminals.

4-7 Connecting motor and regeneration resistor cables

Connect the actuator cable to [U,V,W] terminals of the HA-655 driver as shown in the figure below. Refer to the phase order of the actuator cable in the actuator manual and connect the end terminal of cables to the driver terminal that have the same symbol.

Shown the figure to the right, strip the end of wires of the motor cable and resistor cables, and connect wires to each terminal firmly.

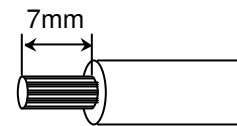

When a regeneration resistor is required, connect its wires to [R1, R2] terminals.

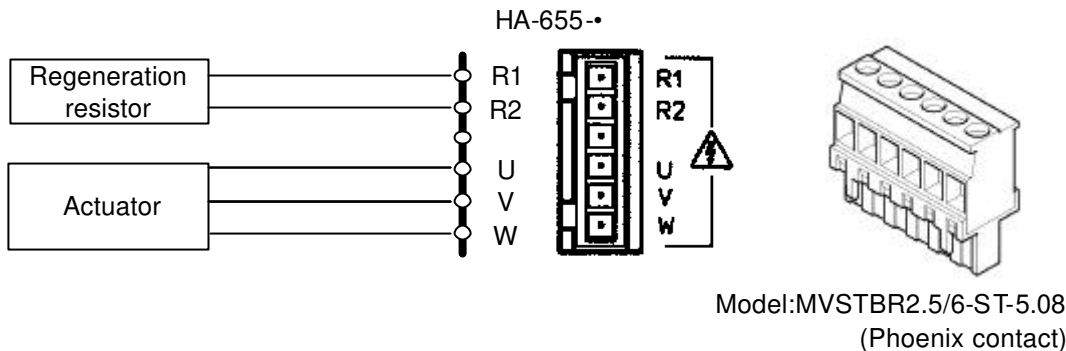

4-8 Connecting cables for the encoder and the I/O

4-8-1 Preparing the encoder cable and the I/O cable

Follow these instructions for the preparation of the encoder cable and the I/O cable.

- (1) Use twisted pair cables for I/O signal cables and for encoder signal cables. When a host controls several drivers, install I/O signal cables for each driver individually.
- (2) Make the length of signal cables as short as possible.
 - ① I/O signal cable: 3m or less
 - ② Encoder signal cable (user's responsibility): 20m or less, providing that the condition of wire conductivity is less than 0.04 ohm/m.

Optional cables of 3m/5m/10m long are available.

- (3) Separate power cables (power source cables and motor cables) and I/O signal cables more than 30cm. Do not encase both cables in one pipe or duct, nor bundle them.
- (4) Do not open the end of analog signal cables as speed signal cables.

Terminals and Connectors	Symbol	Allowable Wire Sizes (mm ²)			
		HA-655-2		HA-655-4	
		FHA-17C	FHA-25C	FHA-32C	FHA-40C
Encoder Port	CN1	0.3mm ² twist pair shielded cable			
I/O Signal Port	CN2	0.35mm ² twist pair, or twist pair whole-shielded cable			

4-8-2 Pin layouts of encoder connector (CN1)

The models and the pin layout of the encoder connector are as follows:

Plug: model: 10114-3000VE manufacturer: 3M
 Shell: model: 10314-52F0-008 manufacturer: 3M

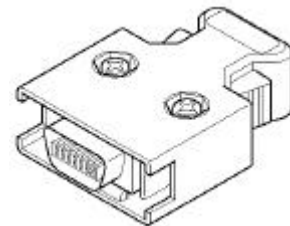

for incremental encoder

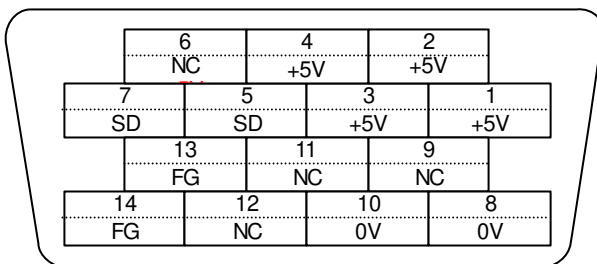

The layout shows the soldering side.

for absolute encoder

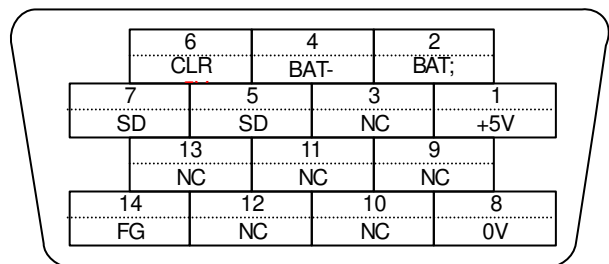

The layout shows the soldering side.

4-8-3 Pin layouts of the I/O signal connector (CN2)

The models and the pin layout of the encoder connector are as follows:

Plug: model: 10150-3000VE manufacturer: 3M
 Shell: model: 10350-52F0-008 manufacturer: 3M

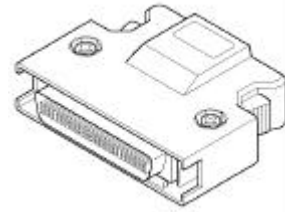

◆ Position mode

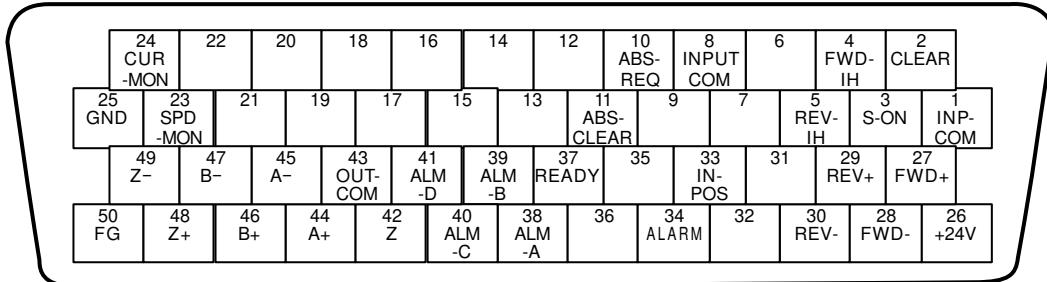

Note 1: The layout shows the soldering side.

Note2: ABS-REQ and ABS-CLEAR are available for the absolute encoder system.

◆ Speed mode

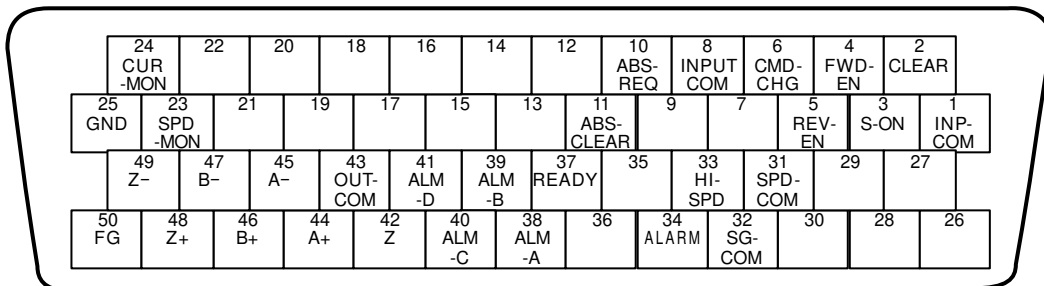

Note 1: The layout shows the soldering side.

Note2: ABS-REQ and ABS-CLEAR are available for the absolute encoder system.

4-8-4 Connecting cables for the encoder and I/O signals

Firmly connect both connectors of the encoder cable and the I/O signal cable to [CN1] and [CN2] sockets respectively.

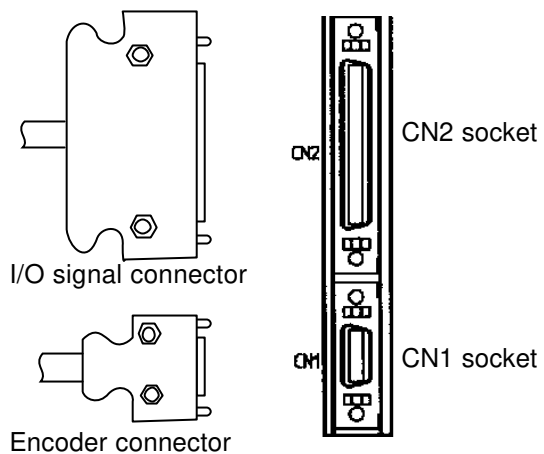

4-9 Power ON and OFF sequences

Plan power ON and power OFF sequences with the timing shown in the figures below.

◆ Power ON sequence << for incremental encoder system >>

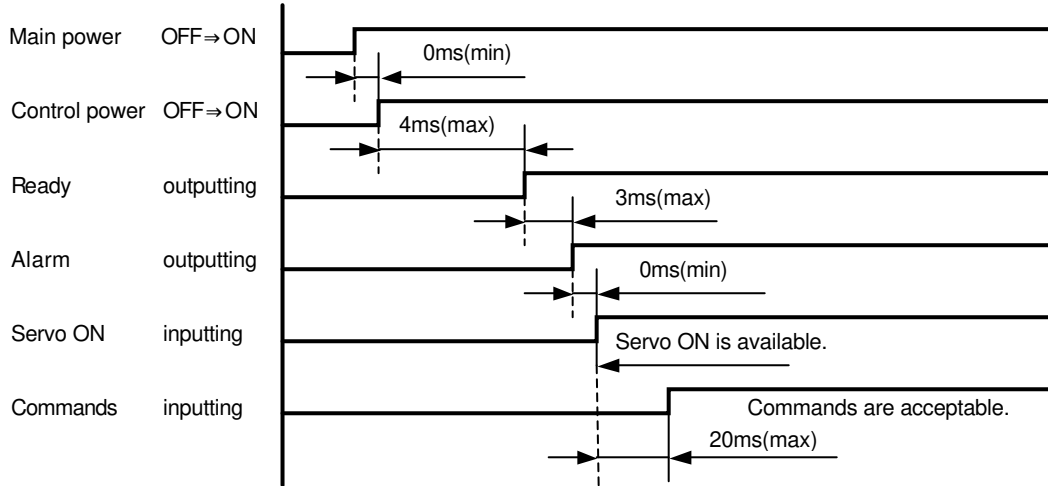

<< for absolute encoder system >>

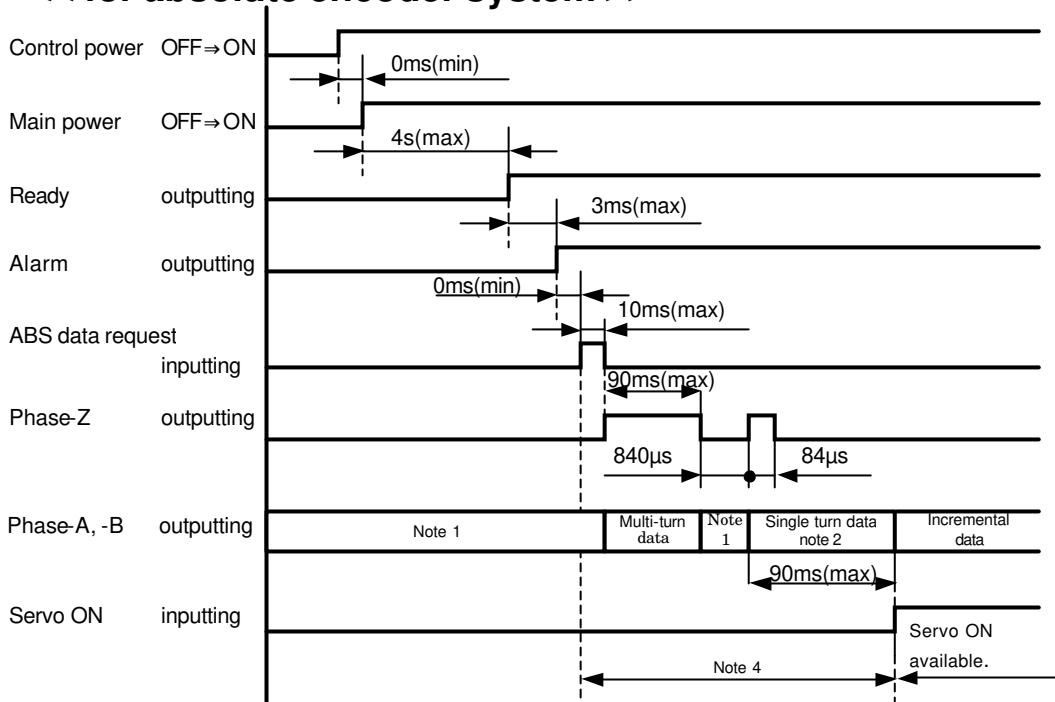

Note 1: Both output signals of phase-A and phase-B are settled at LOW-level. To settle at LOW-level, at least three pulses are outputted. Make a sequence for the host device ignoring outputted pulses while the phase-Z is LOW-level before generating a unique pulse train, and during other LOW-level duration of the phase-Z signal.

Note 2: An absolute pulse train for single-turn encoder is outputted after around 1 ms of outputting phase-Z signal.

Note 3: The servo-ON signal is unaccepted until completing the transmission of a set of unique pulse trains by the [absolute data request] signal.

Note 4: The [alarm 57] may occurs if the single-turn encoder rotates more than 127 resolvable position while the multi-turn counter is transmitting a unique pulse train.

◆ **Power OFF sequence**

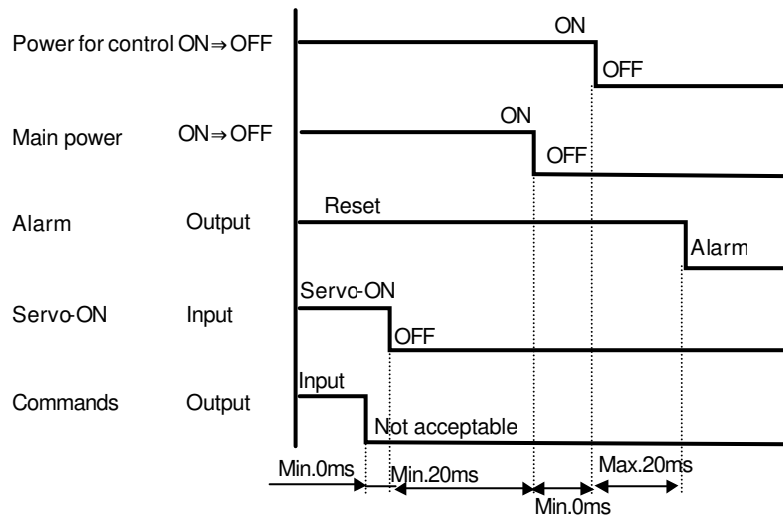

◆ **Switch for main power operation**

Plan the sequence circuit to operate the switch for main power individually by [alarm] signal and [emergency stop] signal.

◆ **Notices for switching main power**

Since the HA-655 driver provides a capacitor for an input filter of a rectifier circuit, large transient current flows at every operation of main power switch. If the switching operation is too frequent, resistors for suppressing the transient current may deteriorate.

The switching frequency should not exceed 5 times in an hour and 30 times in a day. Furthermore, the interval between turning OFF and ON should keep more than 30 seconds.

Do not make switching operation (turning ON or OFF) at the state that the servo-ON [CN2-3:S-ON] is ON.

Chapter 5 Operations

Follow these instructions prior to operations.



CAUTION

1. Inspect the cabling before turning the power ON and correct poor cabling if necessary.
 - (1) Is the cabling correct?
 - (2) Is there any temporary cabling? Are all wires connected to the terminals?
 - (3) Are there any loose terminal connections?
 - (4) Are the wires grounded properly?
2. Never wire the unit or make changes to the wiring while the power is ON. Turn the power OFF first.
3. Clean around the equipment. Make sure there are no wire chips or tools in the equipment.
4. When two or more persons are working on the equipment, make sure all are alerted and safe before power is restored to the machine.

5-1 Test run



CAUTION

1. Complete the test run before actual operation.
2. Drive the actuator only during the test run; disconnect the actuator from the driven mechanism or load.

5-1-1 Driving an actuator without load

Drive the actuator only during the test run.

• Reason for a test run

- (1) Verifying the power cable wiring
- (2) Verifying the actuator cable wiring (the servomotor cable and the encoder cable)
- (3) Verifying the I/O signal communication with the host device

• Procedure of test run

◆ Power-ON and verifying power circuit

- (1) Turn on power to the driver. Turn on power to the host.
 - ☺ Make sure there is not an abnormality.
 - ⇒ Indication (monitor mode) appears on the display of the HA-655 driver.
 - ☞ If no indication appears, there may be faulty power connections. Shut off power and inspect the wiring.

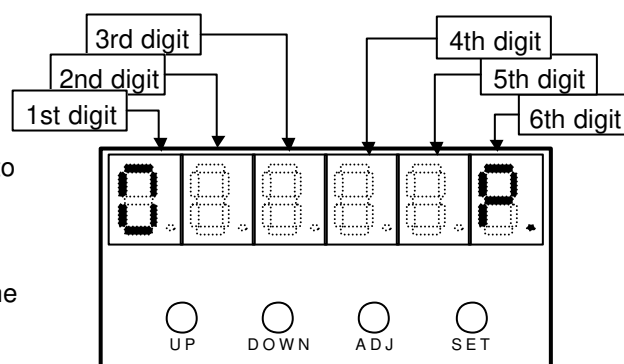

- (2) Turn on main power via the host, and transmit [ON] signal to [CN2-3 servo-ON] from the host.

⇒ Turns the servo drive circuit active, and current can flow to the actuator.

◆ **JOG operation of the actuator**

- (3) To enter the [test mode] from the [monitor mode], press the [SET] key at least three seconds.

⇒ Indicates 6th to 4th digit in the order, and enters the [test mode] when there is no indication on 4th to 6th digit.

- (4) Indicate [Jo] pressing the [UP] key or the [DOWN] key.

- (5) To enter in the [JOG operation] mode, press the [ADJ] key at least 0.1 second.

⇒ The first digit [J] flashes. ⇒ You can operate the actuator.

- (6) To operate the motor forward, press the [UP] key.
⇒ The motor will rotate when the key is pressed, and will stop when the key is released.

- (7) To operate the motor reverse, press the [DOWN] key.
⇒ The motor will rotate when the key is pressed, and will stop when the key is released.

- (8) To exit from the [JOG operation] mode, press the [SET] key at least 0.1 second.
⇒ Flashing of the first digit [J] stops, servo turns OFF, and the [JOG operation] mode terminates.

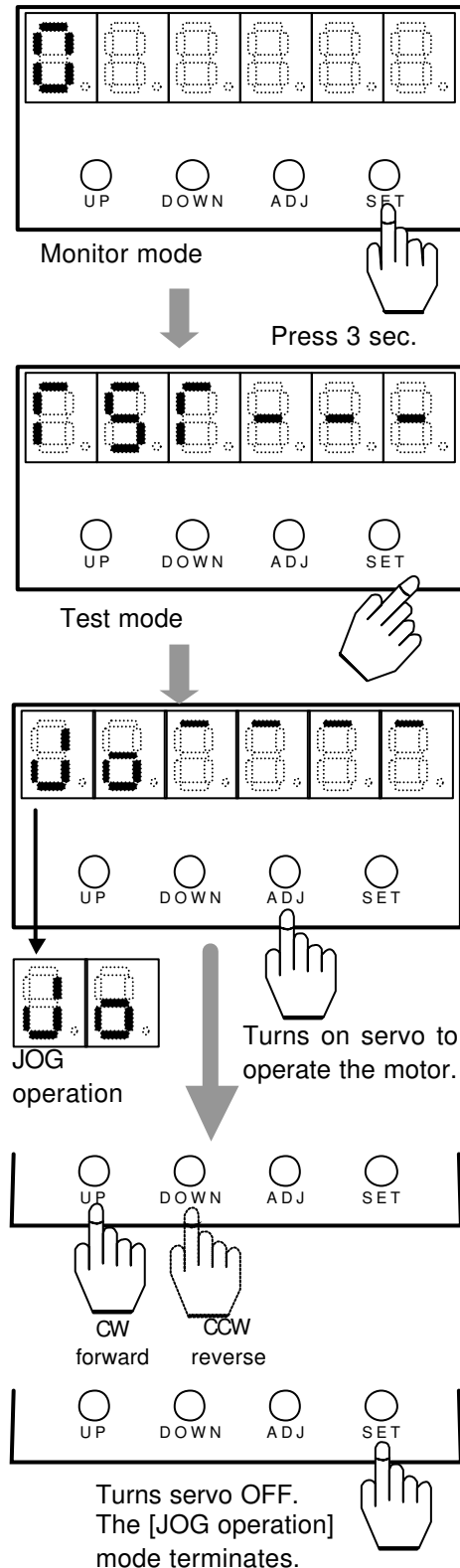

◆ **Verifying Input signals**

- (9) Indicate [c: I/O monitor] by pressing the [UP] key or the [DOWN] key. The forth digit indicates output states and the sixth indicates input states.
- (10) Signal to [CN2-2] ~ [CN2-6] ports from the host.
 - ☺ Verify the indications as shown in the figure below.

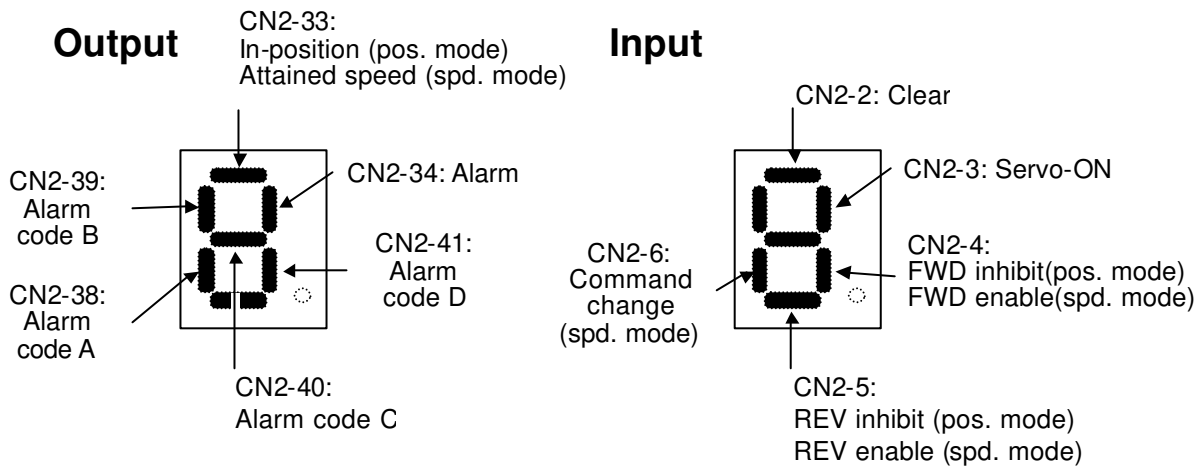
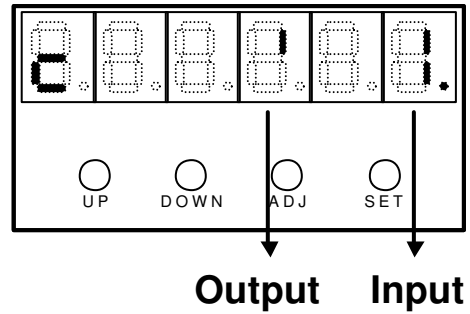

◆ **Verifying output signals**

- (11) Indicate [Inp: output port operation] by pressing the [UP] key or [DOWN] key.
- (12) To operate output ports, press the [ADJ] key at least 0.1 second.

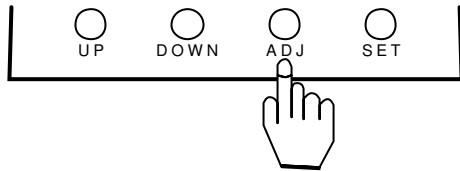

⇒ The first digit flashes. You can operate output ports. (Re-pressing the [ADJ] key at least 0.1 second inhibits [output port operation].)

- (13) Press the [UP] key to specify which output port is to be operated.
⇒ Every pressing the key shifts the code number in the order of the figures to the right.
- (14) Press the [DOWN] key to turn ON/OFF the selected port.
⇒ Every pressing the key turns over the port state (ON → OFF → ON →).
- (15) Check the host input state reacting to the above operation.
☺ Verify the signals are received.
- (16) To terminate operation of the output port, press the [SET] key at least 0.1 second.
⇒ Flashing of the first digit stops and [output port operation] is inhibited.

✋ If abnormal, the output functions of the host or the I/O signal cable may be improperly connected. Shut off power and inspect the I/O cable wiring and host function again.

- (17) Indicate [END] with [UP] and [DOWN] keys. Press [SET] while [End] is indicated.
⇒ The indication mode then returns to the [monitor mode].
- (18) If there is no abnormality during the test run, all wiring is correct.
Continue to the next step of setting parameters.

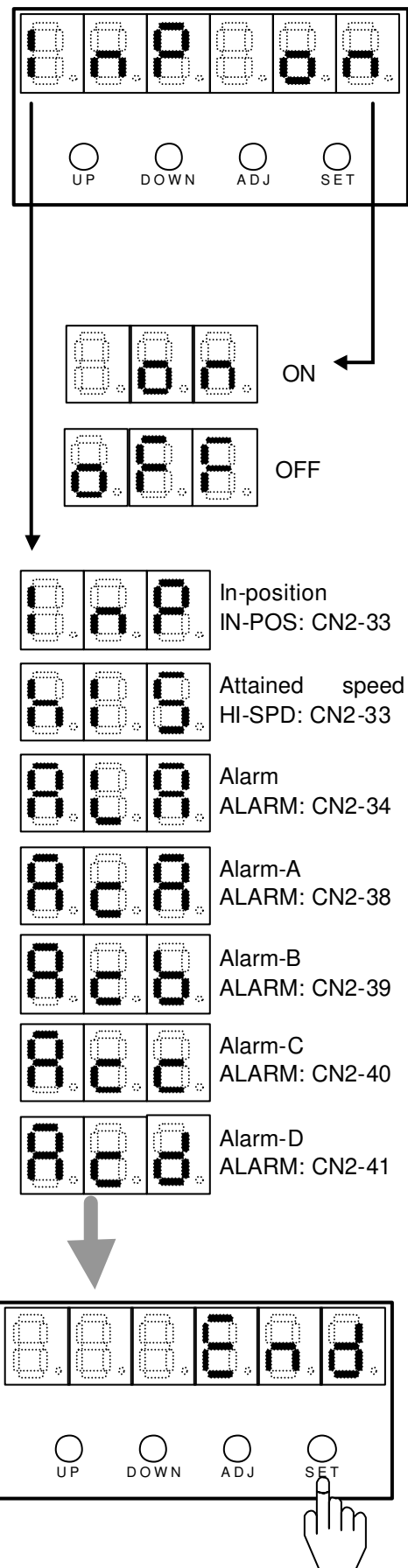

5-1-2 Setting parameters

Following test run of the actuator you can set the parameters via the parameter mode.

All parameters are dependant upon the driven machine system. The abstracts of the parameters in the parameter mode are described in the table below:

Name	Description	Parameters
0: Control mode	Selecting [position mode] or [speed mode] [Position mode]⇒pulse train signal [Speed mode]⇒analog voltage signal	0: position mode 1: speed mode
1: Command configuration	Selecting a command configuration from [2-pulse type],[1-pulse type]and [2-phase pulse type]	0: 2-pulse type 1: 1-pulse type 2: 2 phase pulse type
2: Multiplication of 2-phase pulse	Command pulse train multiplication when command configuration is [2-phase pulse type].	1: Same count of command 2: Double of command 4: Four times of command
3: Electric gear - denominator	Denominator of electronic gear function to make simple relation between displacement of driven mechanism and command pulses.	Integer from 1 to 50
4: Electric gear - numerator	Numerator of the electronic gear function	Integer from 1 to 50
5: Error count clear by Servo-ON	Clearing error count or not clearing by [servo-ON] input signal.	0: No function 1: Clears it
6: Allowable position error	Allowance of position error count ⇒ Alarm 60	1 to 1000
7: Zero clamp	Clamp position or not in [speed mode]	0: No function 1: Zero clamp
8: Rotary direction	Specifying the relation between command polarity and rotary direction	0: FWD for positive com. 1:REV for positive com.
9: Speed conversion factor	Rotary speed to command of 10V in [speed mode]	1 to max. motor speed
A: Speed limit	Upper limit of motor speed	1 to max. motor speed
b: Torque limit	Upper limit of motor torque; 100% to max. torque	1 to 100
c: Alarm logic	Output signal logic of the alarm	0: normal close 1: normal open

(19) To enter the [parameter mode] from the [monitor mode], press both the [ADJ] key and the [SET] key at the same time at least three seconds.

⇒ Enters [parameter mode] when there is no indication on 4th to 6th digit.

Note: While [servo-ON: S-ON (CN2-3 pin)] signal is ON, changing to parameter mode will turn OFF the signal and the system will go into the servo-OFF state.

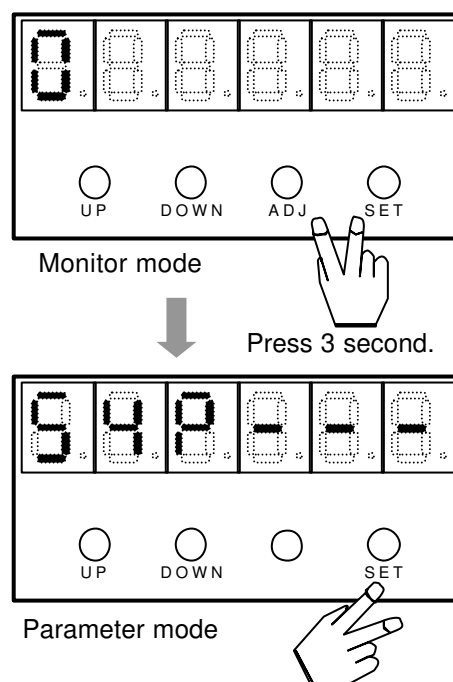

(20) Press [UP] or [DOWN] key to change the functional items of the parameter mode.

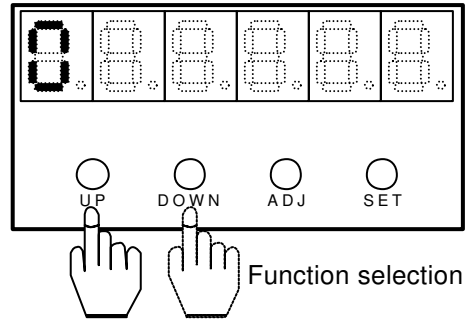

(21) To change a value, press [ADJ] key at least 0.1 second.

⇒ The first digit [0] flashes. You can change the value.

(22) Change the value with the [UP] key and the [DOWN] key.

The [UP] key increases the value.

The [DOWN] key decreases the value.

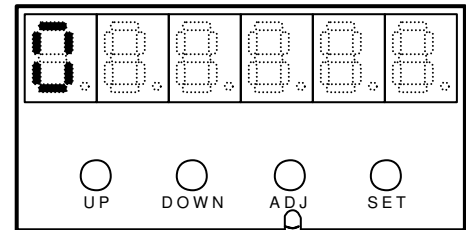

Press 0.1 sec.

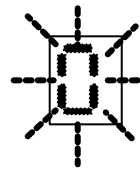

While the first digit code flashes, you can change the value.

Changing

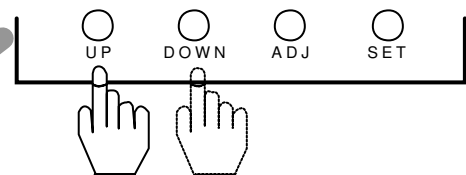

Setting new value

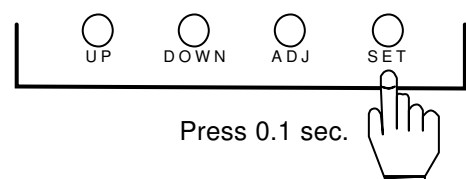

Canceling

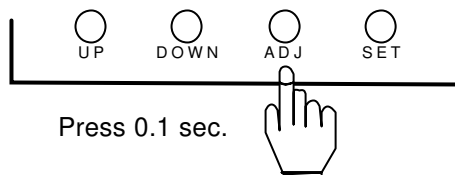

Press 0.1 sec.

(25) To terminate the [parameter mode] and to return to the [monitor mode], press the [SET] key while the [End] is indicated.

⇒ The indication mode then returns to the [monitor mode].

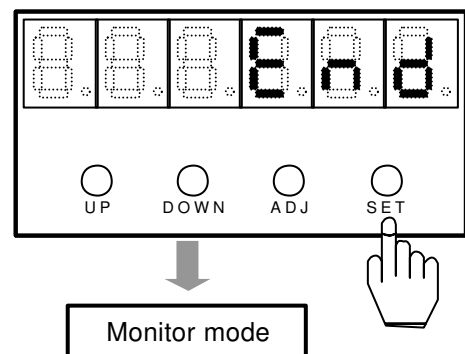

5-1-3 Tuning servo parameters

After setting the parameters of the [parameter mode], couple the actuator with the driven machine; and you can start tuning the servo parameters.

Usually it is unnecessary to tune the parameters, because these servo parameters have been set to the proper values for the actuator as standard defaults. Only if the actuator is hunting, overshooting, or undershooting should you then carefully tune the parameters.

The abstracts of the parameters in [tune mode] are described in the table below:

Name	Description	Parameters
0: Speed loop gain	Proportional speed loop gain to improve response to commands	High: better response; too high: hunting Low: no hunting; too low: overshoot
1: S-loop integral compensation	Lowering the influence of load torque fluctuation	High: No hunting; too high: overshoot Low: better response; too low: hunting
2: Position loop gain	Proportional position loop gain to improve response to commands	High: better response; too high: hunting Low: no hunting; too low: overshoot
3: Feed forward	Improving response at acceleration	High: better response; too high: hunting Low: no hunting
4: In-position range	Allowable error range for positioning	Integer between 1 and 9999
5: Attained speed	Speed to turn on HI-SPD(CN2-33 pin)	Integer between 1 and 9999
6: Internal speed command	Internal speed command	1 to speed limit ([parameter mode]→[A: speed limit])
7: Acceleration constant	Acceleration time from [o] to speed limit ([parameter mode]→[A: speed limit])	0.0 to 10.0seconds
8: Deceleration constant	Deceleration time from speed limit ([parameter mode]→[A: speed limit]) to [0]	0.0 to 10.0seconds
9: Speed command offset	compensating the slight rotation by command voltage offset	± 9999

- (26) Shut power OFF for safety.
- (27) Couple the actuator with the drive machine.
- (28) Turn power ON.
- (29) To enter [tune mode] from [monitor mode], press [ADJ] key at least three second.
→ Enters [tune mode] when there is no indication on 4th to 6th digit.
- (30) Press [UP] or [DOWN] key to change the functional items of the [tune mode].

Note: If the decimal point of the sixth digit is ON the servo is active (ON) and the actuator will respond to command signals. If the decimal point is OFF, the servo is inactive (OFF).

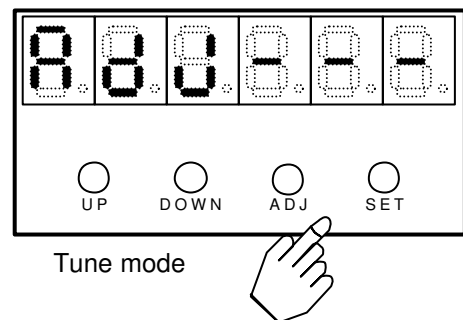
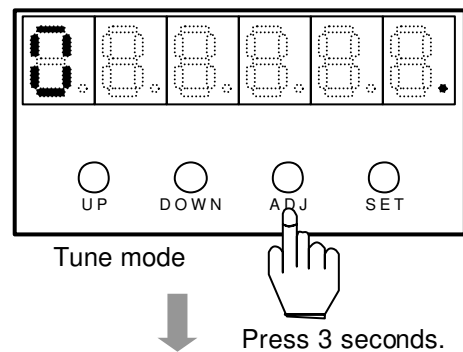
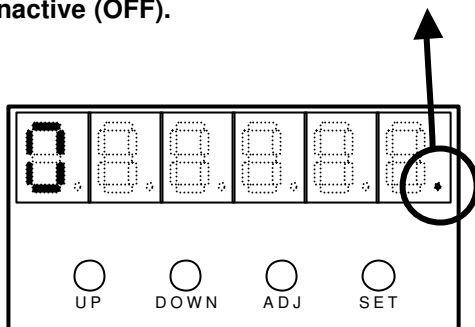

- (31) To change a value, press the [ADJ] key at least 0.1 second.
 ⇒ The first digit [0] flashes. You can change the value.
- (32) Change the value with the [UP] key and the [DOWN] key.
 The [UP] key increases the value.
 The [DOWN] key decreases the value.
- (33) To define the new value, press the [SET] key at least 0.1 second.
 ⇒ The value is stored in the memory. From now on, the new value is effective.
- (34) To cancel the changing operation and to make the previous value effective before, press the [ADJ] key at least 0.1 second.
 ⇒ The previous value is restored.

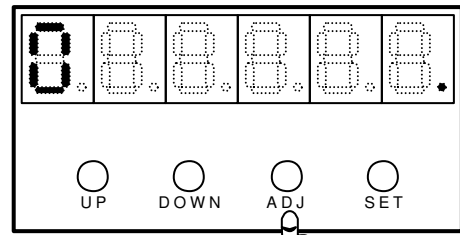

Press 0.1 sec.

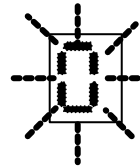

While the first digit code flashes, it is able to change value.

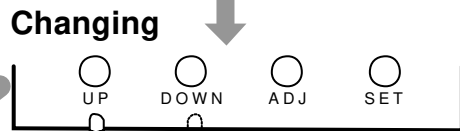

Setting new value



To previous value

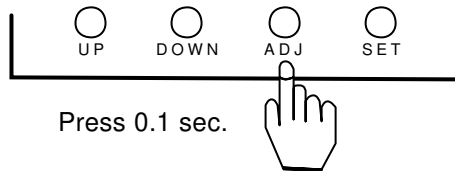

- (35) To terminate the [tune mode] and to return to the [monitor mode], press the [SET] while the [End] is indicated.
 ⇒ The indication mode then returns to the [monitor mode].

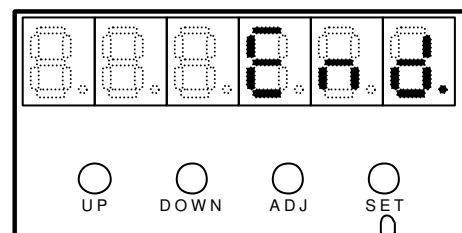

Tune mode

Monitor mode

5-1-4 End of test run

When above operations are finished, terminate the test run.

- (36) Shut the power (OFF).

5-2 Usual operation

As the HA-655 driver runs by commands from a host, no special intervention is required for normal operations. In this section, instructions for daily operations and maintenance are explained.

5-2-1 Notices for daily operations



CAUTION

1. Do not make any wiring while power is active.

Disconnecting wires or connectors while power is active may cause electric shock or abnormal mechanical motion resulting in serious physical injury.

2. Do not touch terminals for at least five minutes after power has been shut off [POWER OFF].

Even during power-OFF, electric charge remains in the driver. Do not touch terminals at least five minutes from power-OFF to avoid electric shock.

2. Do not operate drivers with frequent ON/OFF operation.

Frequent power ON/OFF operation may cause deterioration of electronic elements. Start / stop operation should be performed by using input signals.

5-2-2 Daily maintenance

Since the HA-655 driver employs highly reliable parts, no special daily maintenance is required except the maintenance under user's rules for electronic equipment.



CAUTION

1. Shut down electric power before maintenance.

Maintenance while power is active may cause electric shock.

3. Do not touch terminals for at least five minutes after power-OFF stage.

Even with power-OFF, electric charge remains in the driver. Do not touch terminals at least five minutes after power-OFF to avoid electric shock.

3. Do not perform insulation resistance or high voltage breakdown tests.

The test causes damage to the HA-655 driver circuit that results in abnormal motion.

Check point	Interval	Inspection standard	Treatment
Terminal screws	Yearly	No loosen screws	Tightening screws
Exterior	Yearly	No dust or metal chips on the case	Cleaning
Interior Circuitry	Yearly	No color change, no faults, no abnormalities	Consult with Harmonic drive systems

Chapter 6 Setting up parameters

The display panel of the HA-655 driver is equipped with a six-digit LED display and four operation keys. Monitoring information, tuning operations, setting operations, and jog operation are done using the display panel.

6-1 Summary of modes

The HA-655 driver provides the following four modes of monitor, tuning, parameter, and test:

- ◆ **Monitor mode**

The HA-655 driver indicates position and speed commands, current position information from a motor-encoder, pulse count in an error counter, input and output signal states, load condition, alarm history, and the code number of the actuator. These are useful to diagnose the driver if it fails or operates in an abnormal manner.

After power ON sequence is complete, the [monitor mode] starts up. While the power is active, the monitor mode functions as the main screen switching from and to other modes.

- ◆ **Tuning mode**

The tuning mode provides various parameters to control the actuator motion. Setting the most suitable value for each parameter obtains the optimum performances of the actuator.

- ◆ **Parameter mode**

The parameter mode sets various parameter values relating to the fundamental operational functions such as: specifications of the position mode or the speed mode, configurations of input signals, an electronic gear function, limiting values of speed and torque, and parameters to communicate with a host.

- ◆ **Test mode**

The test mode consists of required functions for system test, such as: JOG operation functions, operations of pseudo output signals, and I/O signal monitors.

6-2 Selecting a mode

After turning on the power, the [monitor mode] starts up automatically. The [ADJ] key and [SET] key select a mode.

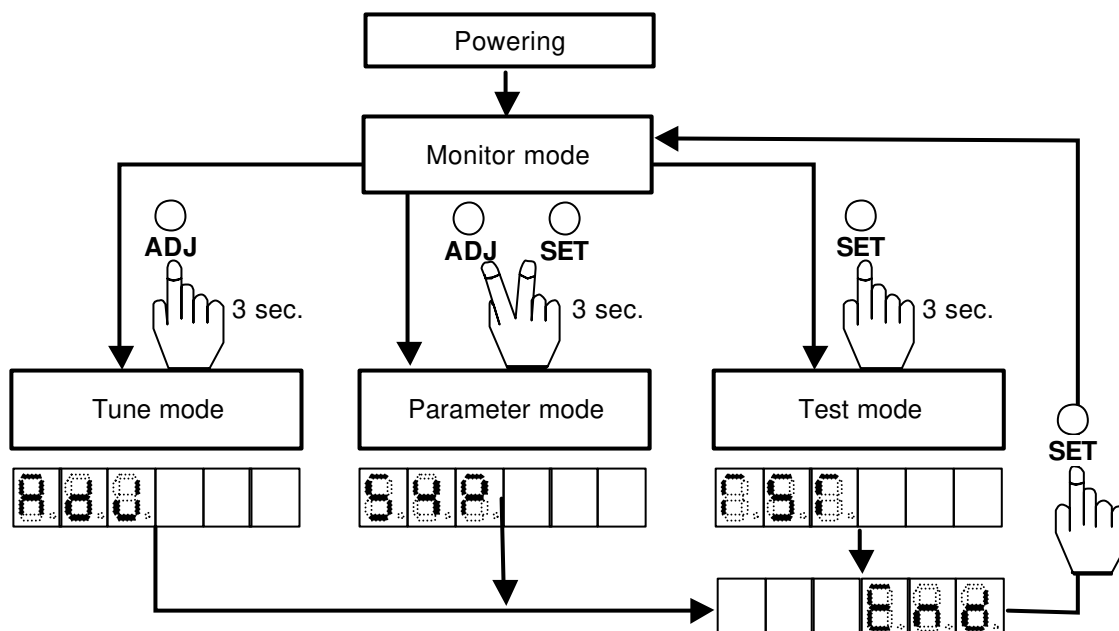

6-3 Functions of modes

Each mode provides the following functions of position mode and speed mode individually.

Mode	Code	Position mode	Setting	Code	Speed mode	Setting
Monitor mode	0	Error counter state	Impossible	0	Error counter state	Impossible
	1	Motor revolutions		1	Motor revolutions	
	2	-----		2	Speed command voltage	
	3	Error pulse count (Low)		3	Error pulse count (Low)	
	4	Error pulse count (High)		4	Error pulse count (High)	
	5	Torque monitor		5	Torque monitor	
	6	Overload rate		6	Overload rate	
	7	Feedback pulse (Low)		7	Feedback pulse (Low)	
	8	Feedback pulse (High)		8	Feedback pulse (High)	
	9	Command pulse (Low)		9	-----	
	A	Command pulse (High)		A	-----	
	b	Command pulse frequency		b	-----	
	c	I/O monitor		c	I/O monitor	
	d	Alarm history		d	Alarm history	
	E	Actuator code		E	Actuator code	
F	Serial number	F	Serial number			
Tune mode	0	Speed loop gain	Possible	0	Speed loop gain	Possible
	1	S-loop integral compensation		1	S-loop integral compensation	
	2	Position loop gain		2	Position loop gain	
	3	Feed-forward gain		3	-----	
	4	In-position range	4	-----		
	5	-----	-----	5	Attained speed	Possible
	6	-----	-----	6	Internal speed command	
	7	-----	-----	7	Acceleration time constant	
	8	-----	-----	8	Deceleration time constant	
	9	-----	-----	9	Speed command offset	
Parameter mode	0	Control mode	Possible	0	Control mode	Possible
	1	Command configuration		1	-----	-----
	2	Multiplication of 2-phase pulse		2	-----	-----
	3	Electronic gear - denominator		3	-----	-----
	4	Electronic gear - numerator		4	-----	-----
	5	Error count cleared by S-ON		5	-----	-----
	6	Position error allowance	6	-----	-----	
	7	-----	-----	7	Zero clamp	Possible
	8	Rotary direction	8	Rotary direction		
	9	Speed conversion factor	9	Speed conversion factor		
	A	Speed limit	A	Speed limit		
	b	Torque limit	b	Torque limit		
	c	Alarm logic	c	Alarm logic		
	d	-----	-----	d	-----	
E	-----	-----	E	-----	-----	
F	* ABS multi-turn data clear	Impossible	F	* ABS multi-turn data clear	Impossible	
Test mode	Jo	JOG operation	Possible	Jo	JOG operation	Possible
	SP	JOG speed	Possible	SP	JOG speed	Possible
	Ac	JOG acceleration		Ac	JOG acceleration	
	InP	Output port operation	Possible	InP	Output port operation	Possible
	c	I/O monitor	Impossible	c	I/O monitor	Impossible
	An	Analog monitor manual output	Possible	An	Analog monitor manual output	Possible
	So	Speed command auto-offset	Possible	So	Speed command auto-offset	Possible

6-4 Monitor mode

The HA-655 driver indicates position and speed commands, current position information from a motor-encoder, pulse count in an error counter, input and output signal states, load condition, alarm history, and the code number of the actuator. These are useful to diagnose the driver if it fails or operates in an abnormal manner.

After powering, the [monitor mode] starts up. While the power is on, from the monitor mode as the main screen, it is possible to switch to and from other modes.

The monitor mode indicates the following items.

Mode	Code	Position mode	Setting	Code	Speed mode	Setting
Monitor mode	0	Error counter state	Impossible	0	Error counter state	Impossible
	1	Motor revolutions		1	Motor revolutions	
	2	-----		2	Speed command voltage	
	3	Error pulse count (Low)		3	Error pulse count (Low)	
	4	Error pulse count (High)		4	Error pulse count (High)	
	5	Torque monitor		5	Torque monitor	
	6	Overload rate		6	Overload rate	
	7	Feedback pulse (Low)		7	Feedback pulse (Low)	
	8	Feedback pulse (High)		8	Feedback pulse (High)	
	9	Command pulse (Low)		9	-----	
	A	Command pulse (High)		A	-----	
	b	Command pulse frequency		b	-----	
	c	I/O monitor		c	I/O monitor	
	d	Alarm history		d	Alarm history	
	E	Actuator code		E	Actuator code	
	F	-----		F	-----	

6-4-1 Operating in the monitor mode

After powering or finishing operations in other modes, the drive automatically transfers to the [monitor mode]. Therefore, there is no special code for the [monitor mode].

• Operation procedure

- To transfer to the [monitor mode] from other modes, press the [SET] key after displaying the [END].
→ The monitor mode begins.
- Press the [UP] key or the [DOWN] key to change the functional items of the monitor mode.
→ Every pressing the [UP] key shifts a code of the first digit one by one from [0] to [E], and indicates a value corresponding to the code.

→ Every pressing the [DOWN] key shifts a code of the first digit one by one from [E] to [0], and indicates a value corresponding to the code.

• Details of display

1st digit: Codes in the mode.

Decimal point of the sixth digit:

When the point is on, the servo is active (ON) and the actuator is able to respond to a command signal. When the point is off, the servo is inactive (OFF).

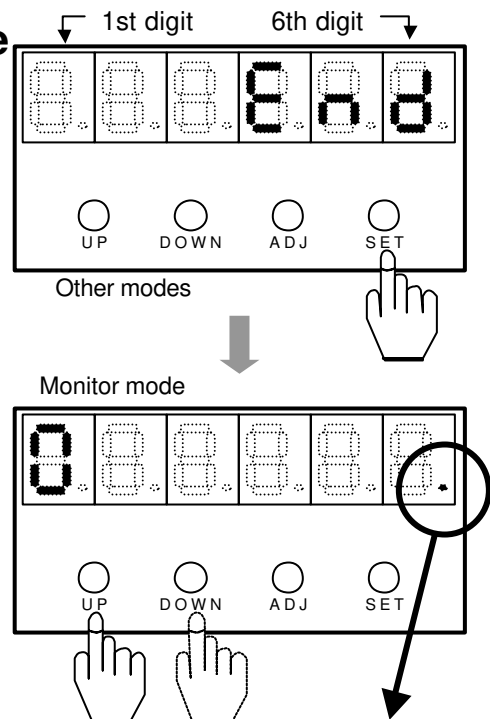

6-4-2 Functions of the monitor mode



Error counter state

(position / speed mode)

• Function

The fundamental functions of servomotors are for positioning and rotation responding to command signals. A block diagram of servo motor control is shown as follows:

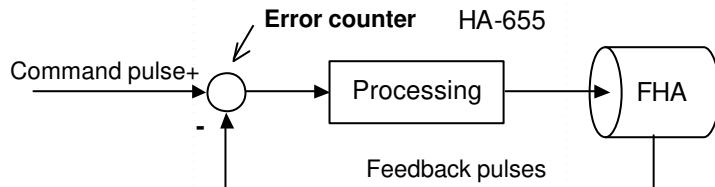

Position commands in the position mode are inputted into the HA-655 driver from a host as the “command pulse count.” The HA-655 driver outputs rotation commands to the actuator proportional to the command pulses. When the actuator starts rotation, the position sensor (encoder) feeds back a current position the HA-655 driver as the “feedback pulse count.”

The HA-655 driver continues outputting rotation commands to the actuator until there is no difference (error pulse count) from command pulse count to feedback pulse count.

The error counter calculates this error pulse count.

The error counter state indicates either speed or position mode. In addition to the position mode, the current position is inside or outside of the in-position range.

• Details of display

1st digit: [0:Error counter state]

2nd to 5th

digit: No indication

6th digit [P]: Indicates the current position is inside of the “in-position range” in the position mode.

[o]: Indicates the current position is outside of the “in-position range” in the position mode.

[S]: Indicates the current state in the speed mode.

• Related functions

[Command pulse]: [Monitor mode] → [9:Command pulse(Low)], [A: Command pulse(High)]

[Feedback pulse]: [Monitor mode] → [7:Feedback pulse(Low)], [8:Feedback pulse(High)]

[Error pulse count]: [Monitor mode] → [3:Error pulse count(Low)], [4:Error pulse count(High)]

[In-position range]: [Tune mode] → [In-position range]

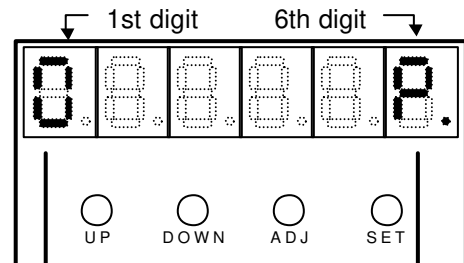

Error counter state



Current position is inside the “in-position range” in the position mode.



Current position is outside the “in-position range” in the position mode.



Current state is in the speed mode.

[Monitor mode]



Motor speed

(position / speed mode)

- **Function**

The “motor speed” indicates the present motor speed in r/min.

The actuator speed is obtained by dividing the motor speed by the reduction ratio of the actuator gear.

- **Details of display**

1st digit: [1: Motor speed]

2nd digit: No indication means positive counts, and [-] indicates negative counts.

3rd to 6th digit: Indicates motor speed in r/min.

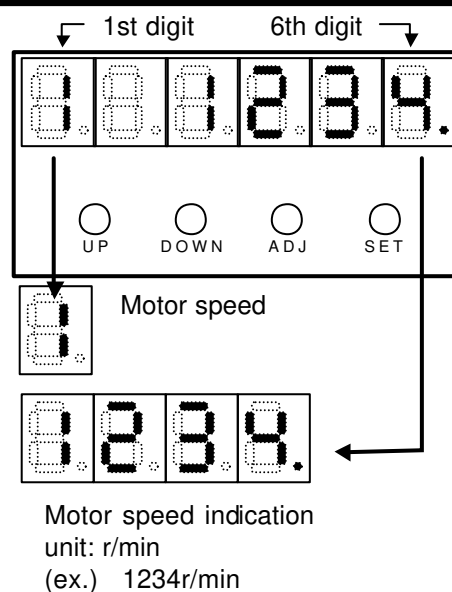

Speed command voltage

(speed mode)

- **Function**

This indicates the present speed command voltage (unit: V) to the HA-655 driver in the speed mode.

The parameter [9: speed conversion factor] of parameter mode relates the speed command voltage and the motor speed.

+ 10V/- 10V: Motor maximum speed(forward/reverse)

The actuator speed is obtained by dividing motor speed by the reduction ratio of the actuator. Therefore the actuator speed is obtained by the following formula:

$$\text{Actuator speed} = \frac{\text{Motor max. speed}}{\text{Reductionratio}} \times \frac{\text{Speed command voltage}}{10}$$

- **Details of display**

1st digit: [2: Speed command voltage]

2nd digit: No indication means positive counts, and [-] indicates negative counts.

3rd digit: No indication

4th to 6th digit: Indicates [Speed command voltage](unit: V)

- **Related functions**

[Speed conversion factor]: [Parameter mode] → [9:Speed conversion factor]

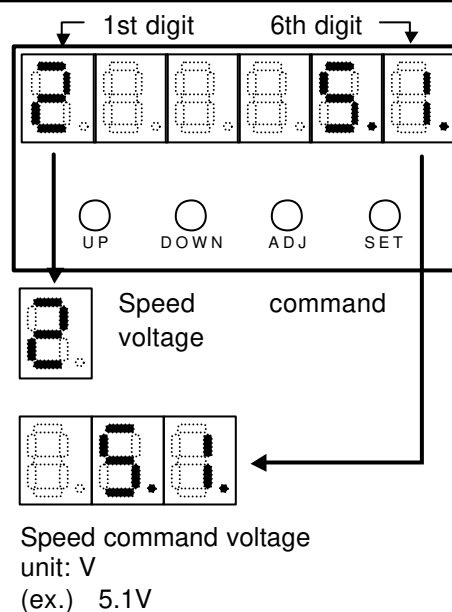

[Monitor mode]

3 Error pulse count (low) (position / speed mode)

• Function

The fundamental functions of servomotors are for positioning and rotation responding to a command signals. A block diagram of servo motor control is shown as follows:

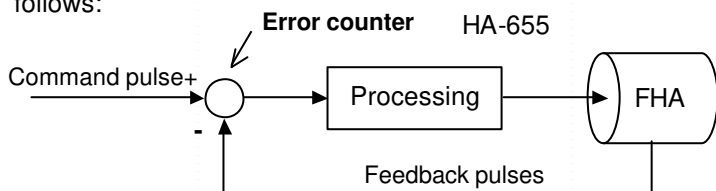

Position commands in the position mode are input into the HA-655 driver from a host as the "command pulse count." The HA-655 driver outputs rotation commands to the actuator proportioning to the command pulses. When the actuator starts rotation, the position sensor (encoder) feeds back a current position into the HA-655 driver as the "feedback pulse count."

The HA-655 driver continues outputting rotation commands to the actuator until there is no difference (error pulse count) from "command pulse count" to "feedback pulse count."

This indicates the lower part of the current error pulse count.

• Details of display

1st digit: [3: error pulse count (low)]

2nd digit: No indication means positive counts, and [-] indicates negative counts.

3rd to 6th digit: Indicates current quadrate error pulse counts in pulse unit.

• Related functions

[Command pulse]: [Monitor mode] → [9: Command pulse (Low)], [A: Command pulse (High)]

[Feedback pulse]: [Monitor mode] → [7: Feedback pulse (Low)], [8: Feedback pulse (Low)]

[Error counter state]: [Monitor mode] → [0: Error counter state]

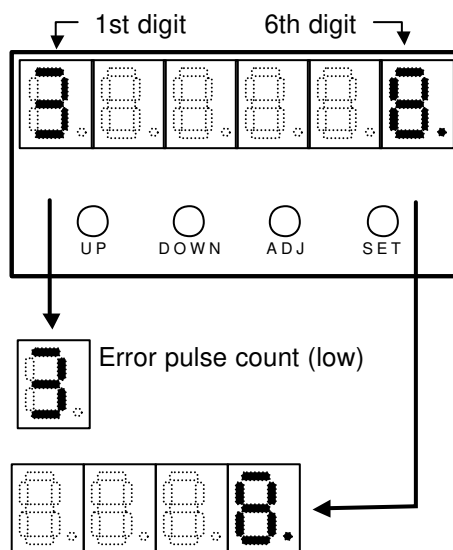

Current quadrate error pulse counts
Unit: pulse
(ex.) Quadrate error pulse = 8

8 Error pulse count (high) (position / speed mode)

• Function

This indicates the high part of an error quadrate pulse count.

Combining with the [4:error pulse count (high)], the whole quadrate error pulse count is indicated.

• Details of display

1st digit: [4: error pulse count (high)]

2nd digit: No indication means positive counts, and [-] indicates negative counts.

3rd to 6th digit: Indicates current quadrate error pulse counts in pulse unit.

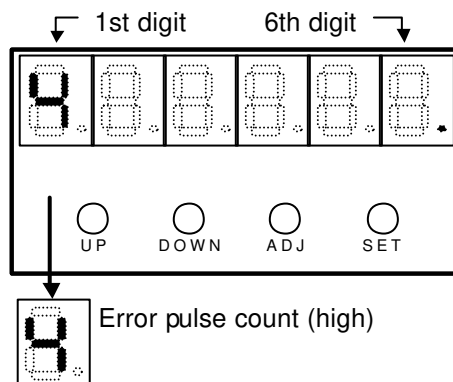

[Monitor mode]



Torque Monitor

(position / speed mode)

- **Function**

This indicates current output torque of the actuator in “%” where “100%” corresponds to the maximum torque.

- **Details of display**

- 1st digit: [5: Torque monitor]
- 2nd digit: No indication means positive counts, and [-] indicates negative counts.
- 3rd digit: No indication
- 4th to 6th digit: Indicates current output torque in “%” where “100%” corresponds to the maximum torque.

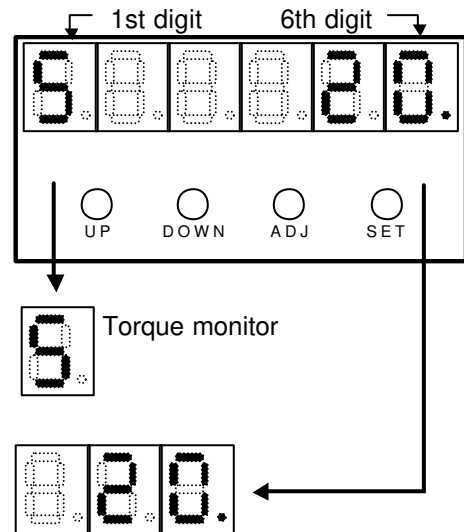

Current output torque where “100%” corresponds to the maximum torque
Unit: %
(ex.) Torque = 20%



Overload rate

(position / speed mode)

- **Function**

This indicates current overload rate of the actuator in “%.” The rate is determined by the overload protection characteristics of the motor. If the value reaches [100], the overload protection function shuts off the motor current, and issues an [Alarm 20].

- **Details of display**

- 1st digit: [6: Overload rate]
- 2nd to 3rd digit: No indication
- 4th to 6th digit: Indicates the current [overload rate] in “%” where “100%” is equal to the [overload protection characteristics] of the motor.

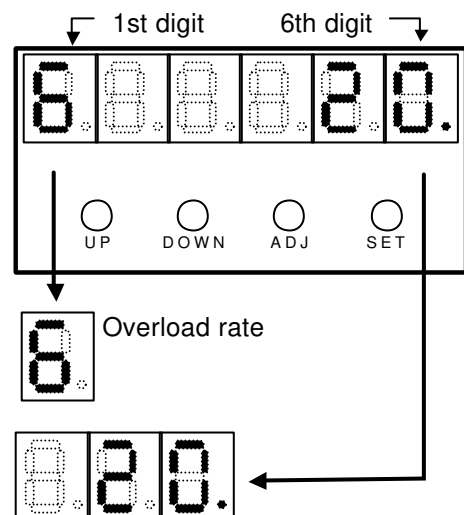

The current overload rate where “100%” is equal to the [overload protection characteristics] of the motor.
Unit: %
(ex.) Overload rate=20%

[Monitor mode]

8 Feedback pulse (Low) (position / speed mode)

• Function

The fundamental functions of servomotors are positioning and rotation responding to a command signal. A block diagram of servo motor control is shown as follows:

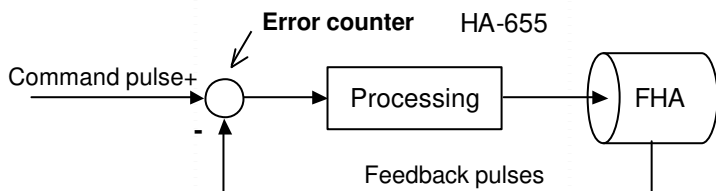

[Feedback pulse] indicates a feedback quadrature pulse count (accumulated) that is reset to [0] position when the HA-655 driver is powered. As the count will become a large number, the count is divided in two parts: low 4th digit part and high part (up to 4th digits).

[7: Feedback pulse (Low)] indicates the low part, and [8: feedback pulse (high)] indicates the high part.

• Details of display

1st digit: [7: Feedback pulse (Low)]

2nd digit: no indication: positive (forward) position, [-]: negative (reverse) position

3rd to 6th digit: Indicates a feedback quadrature pulse count (accumulated) that is reset to the [0] position when the HA-655 driver is powered.

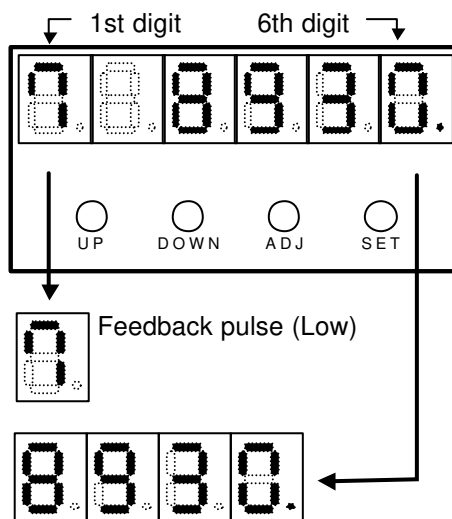

Low 4th digit part of feedback quadrature pulse count
Unit: 4 times of feedback pulse
(ex.) Low 4th digit part of feedback quadrature pulses = 8930

8 Feedback pulse (High) (position / speed mode)

• Function

This indicates the high part of a feedback quadrature pulse count (accumulated).

Combining with the [6: feedback pulse (Low)], the whole pulse count is indicated.

The high part of the example is "1932" and the low part "8930", therefore the feedback quadrature count is "19328930."

• Details of display

Same as [7: feedback pulse (Low)]

• Related functions

[Command pulse]: [Monitor mode] → [9: Command pulse (Low)], [A: Command pulse (High)]

[Error pulse count]: [Monitor mode] → [3: Error pulse count (Low)], [4: Error pulse count (High)]

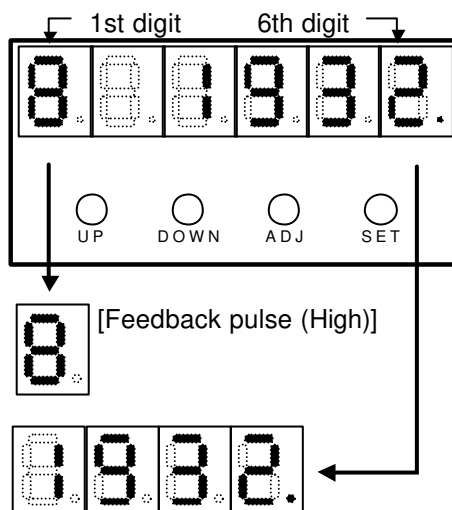

High part of feedback quadrature pulse count
Unit: 4 times of feedback pulse
(ex.) High part of feedback quadrature pulses = 1932

[Monitor mode]



Command pulse (Low)

(position mode)

- Function**

The fundamental functions of servomotors are for positioning and rotation responding to a command signal. A block diagram of servo motor control is shown as follows:

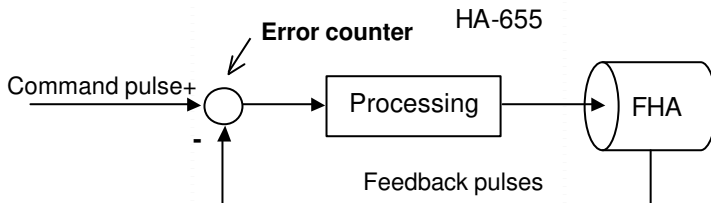

Position commands in the position mode are inputted into The HA-655 driver from a host as the command pulse count. The command is accumulated from the time of powering. As the count will become a large number, the count is divided in two parts: low 4th digit part and high part (up to 4th digits).

[9: Command pulse (low)] indicates the low part, and [A: Command pulse (high)] indicates the high part.

- Details of display**

1st digit: [9: Command pulse (Low)]

2nd digit: no indication: positive (forward) position, [-]: negative (reverse) position

3rd to 6th digit: Indicates a command count (accumulated) that is reset to the [0] position when the HA-655 driver is powered.

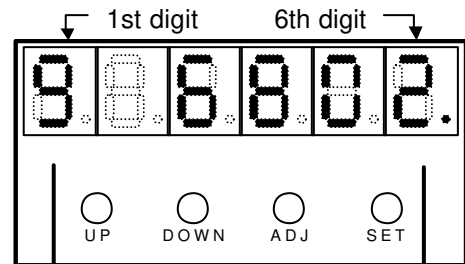

9 Command pulse (Low)

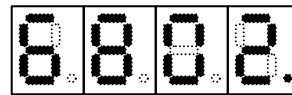

Low 4th digit part of command pulse count

Unit: pulse (accumulated)

(ex.) Low 4th digit part of command pulses = 6802



Command pulse (High)

(position mode)

- Function**

This indicates the high part of the command pulse count (accumulated).

Combining with the [9: command pulse (Low)], the whole pulse count is indicated.

The high part of the example is "31" and the low part "6802", therefore the feedback quadrature count is "316802."

- Details of display**

Same as [9: command pulse (Low)]

- Related functions**

[Feedback pulse]: [Monitor mode] → [7: Feedback pulse (Low)], [8: Feedback pulse (High)]

[Error pulse count]: [Monitor mode] → [3: Error pulse count (Low)], [4: Error pulse count (High)]

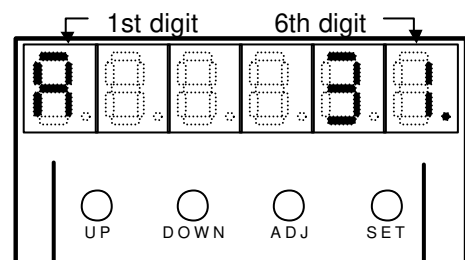

8 [Command pulse (High)]

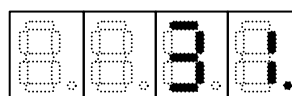

High part of command pulse count

Unit: pulse

(ex.) High part of command pulses = 31

[Monitor mode]



Command pulse frequency

(position mode)

• Function

The fundamental functions of the servomotors are for positioning and rotation responding to a command signal. A block diagram of servo motor control is shown as follows:

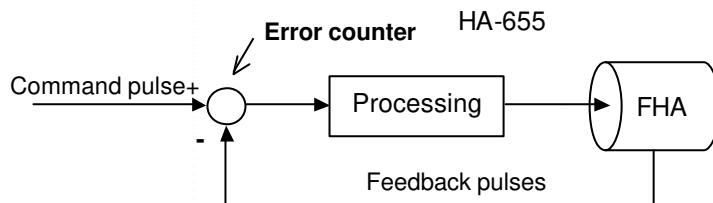

Position commands in the position mode are inputted into [CN2 26-30] pin of the HA-655 driver from a host as the "command pulse count."

The monitor indicates the command pulse frequency in kp/s unit. The limit of the frequency is as follows:

Line driver command:	500 kp/s
Open collector command:	200 kp/s

Note: The maximum actuator speed limits the frequency also.

• Details of display

1st digit: [b: Command pulse frequency]
 2nd digit: No indication
 3rd to 6th digit: Command pulse frequency (unit: kp/s)

• Related functions

[Command pulse]: [Monitor mode] → [9: Command pulse (Low)], [A: Command pulse (High)]

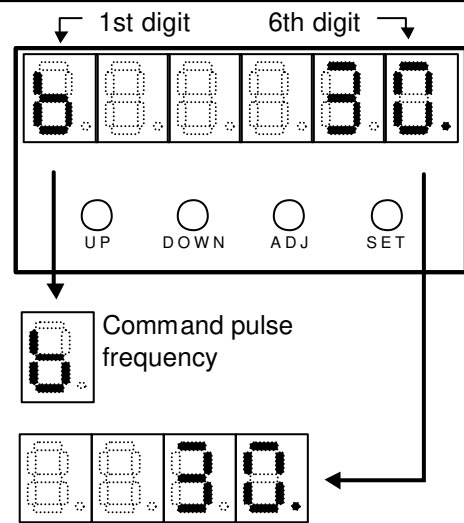

Command pulse frequency
 Unit: kp/s
 (ex.) Command pulse frequency
 = 30kp/s

[Monitor mode]



I/O monitor

(position / speed mode)

• Function

The display indicates input/output signal states of [CN2] connector pins as follows:

Output signals: Forth digit
 Input signals: Sixth digit

Each element of both 7-segment indicators lights up when the related signal is input or output.

The indications are limited only for logical signals, not for encoder signals.

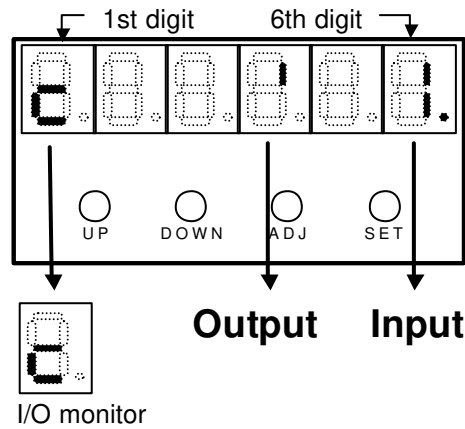

• Details of display

1st digit: [c:I/O monitor]
 2nd digit: No indication
 3rd to 4th digit: Indicates output signal states
 5th digit: No indication
 6th digit: Indicates input signal states

for outputs

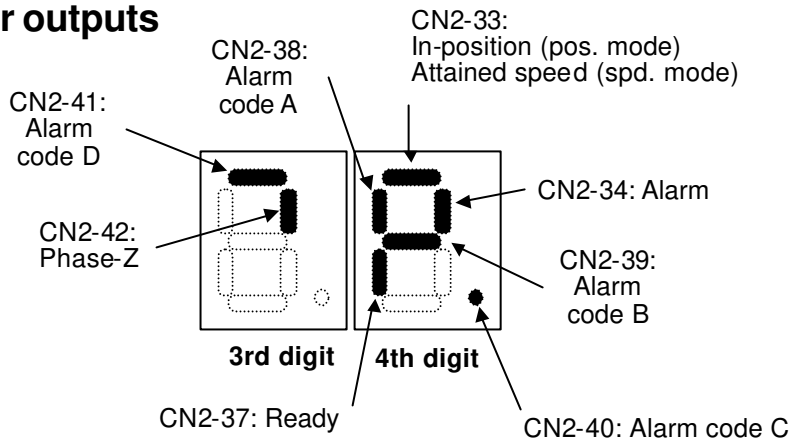

for inputs

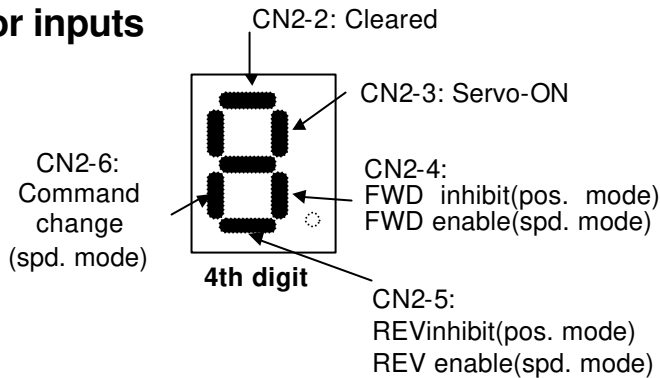

[Monitor mode]



Alarm history

(position / speed mode)

• Function

The “alarm history” indicates up to eight previous alarms with codes.

• Details of display

- 1st digit: [d: alarm history]
 2nd digit: The order of the indicated alarm:
 [1] indicates the latest alarm, and [8] indicates the earliest one.
 3rd to 4th digit: No indication
 5th to 6th digit: Indicates an alarm code.

Code	Alarm description
10	Over speed
20	Over load
21	Overheat
30	Over current
41	Abnormal regeneration
50	Encoder failure
51	Abnormal encoder signal
52	UVW failure
53	*ABS system failure
54	*ABS MTD over flow
55	*ABS multi-turn data error
56	*ABS low battery voltage
57	*ABS send data rule error
60	Error counter overflow
70	Memory failure (RAM)
71	Memory failure (EEPROM)
76	CPU failure

Notice: the alarm codes 53rdrough 57 are valid for absolute encoders only.

• Operations

- (1) To indicate earlier alarm codes, press the [UP] key.
 ⇒ Every pressing the [UP] key increases the alarm-order on the second digit, and indicates the alarm code on the 5th to 6th digit corresponding to the alarm order. The alarm-order on the 2nd digit is limited to [8]. Pressing the [UP] key more is neglected.
- (2) To indicate later alarm codes, press the [DOWN] key.
 ⇒ Every pressing the [DOWN] key decreases the alarm-order on the second digit, and indicates the alarm code on the 5th to 6th digit corresponding to the alarm order. The alarm-order on the 2nd digit is limited to [1]. Pressing the [DOWN] key more is ignored or disregarded.

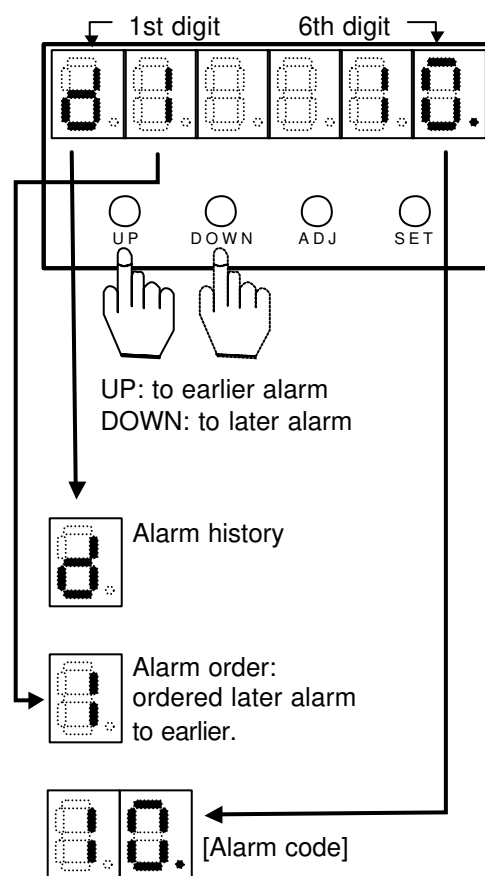

[Monitor mode]



Actuator code

(position / speed mode)

- Function**

This indicates the code of the HA-655 driver is set for. The relation of the codes and actuators is as follows:



CAUTION

Do not connect an actuator that has another code than the indicated code.

Wrong combinations of HA-655 drivers and actuators may cause low torque problems and over current that may cause physical injury and fire.

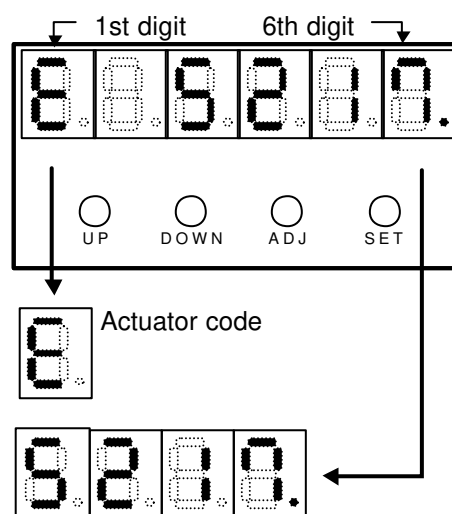

The actuator code of [5217] means that the actuator to be combined is FHA-17C-50 equipped an incremental encoder.

Encoder	Incremental encoder			Absolute encoder		
	Reduction ratio	1/50	1/100	1/160	1/50	1/100
FHA-17C	5217	5237	5247	5218	5238	5248
FHA-25C	5417	5437	5447	5418	5438	5448
FHA-32C	5617	5637	5647	5618	5638	5648
FHA-40C	5717	5737	5747	5718	5738	5748

Note: The above table is available for 200V system only.

- Details of display**

1st digit: [E: Actuator code]

2nd digit: No indication

3rd to 6th digit: Indicates an [Actuator code]. The relation of the codes and actuators is shown above.

6-5 Tune mode

The tuning mode consists of various parameters to control the actuator motion. Setting the most suitable value for each parameter will ensure the optimum performance of the actuator.

The tune mode indicates and sets the following items.

Mode	Code	Position mode	Setting	Code	Speed mode	Setting
Tune mode	0	Speed loop gain	Possible	0	Speed loop gain	Possible
	1	S-loop integral compensation		1	S-loop integral compensation	
	2	Position loop gain		2	Position loop gain	
	3	Feed-forward gain		3	----	
	4	In-position range	4	----		
	5	----	5	Attained speed	Possible	
	6	----	6	Internal speed command		
	7	----	7	Acceleration time constant		
	8	----	8	Deceleration time constant		
9	----	9	Speed command offset			

6-5-1 Operating in the tune mode

- **Selecting operations of function items**

- (1) To transfer to the tune mode from the monitor mode, press the [ADJ] key at least three seconds.
 ⇒ Transfers to the tune mode when there is no indication on 4th to 6th digit.
- (2) Press the [UP] key or the [DOWN] key to change the functional items of the tune mode.
 ⇒ Every pressing the [UP] key shifts a code of the first digit one by one from [0] to [9], and indicates a value corresponding to the code.
 ⇒ Every pressing the [DOWN] key shifts a code of the first digit one by one from [9] to [0], and indicates a value corresponding to the code.

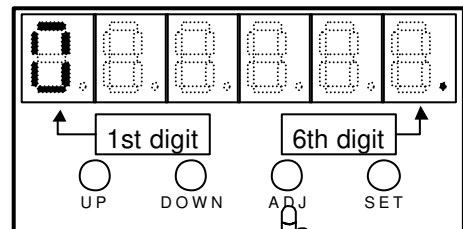

Monitor mode

Press 3 seconds

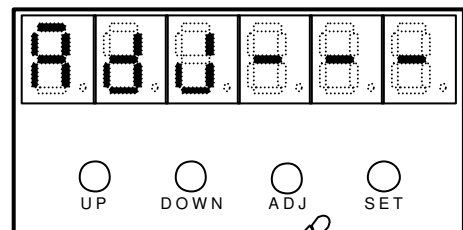

Tune mode

- **Function**

- (1) Transferring to the tune mode:
 1st to 3rd digit: Indicates [AdJ].
 4th to 6th digit: Indicates [-] throughout the transfer.
- (2) For the tune mode:
 1st digit: Codes in the mode.

Decimal point of the sixth digit:

If the decimal point of the sixth digit is ON, the servo is active (ON) and the actuator will respond to command signals. If the decimal point is OFF, the servo is inactive (OFF).

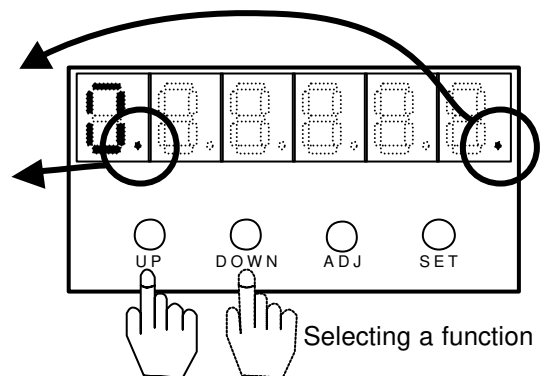

Selecting a function

• **Operations of values**

- (1) To change a value, press the [ADJ] key at least 0.1 second.
⇒ 1st digit [0] flickers. You can change the value.
- (2) Change the value with the keys of [UP] and [DOWN].
The [UP] key increases the value.
The [DOWN] key decreases the value.
- (3) To define the new value, press the [SET] key at least 0.1 second.
⇒ The value is stored in the memory. From now on, the new value is effective.
- (4) To cancel a change in operation and to make the previous value effective before defining, press the [ADJ] key at least 0.1 second.
⇒ The previous value is restored.

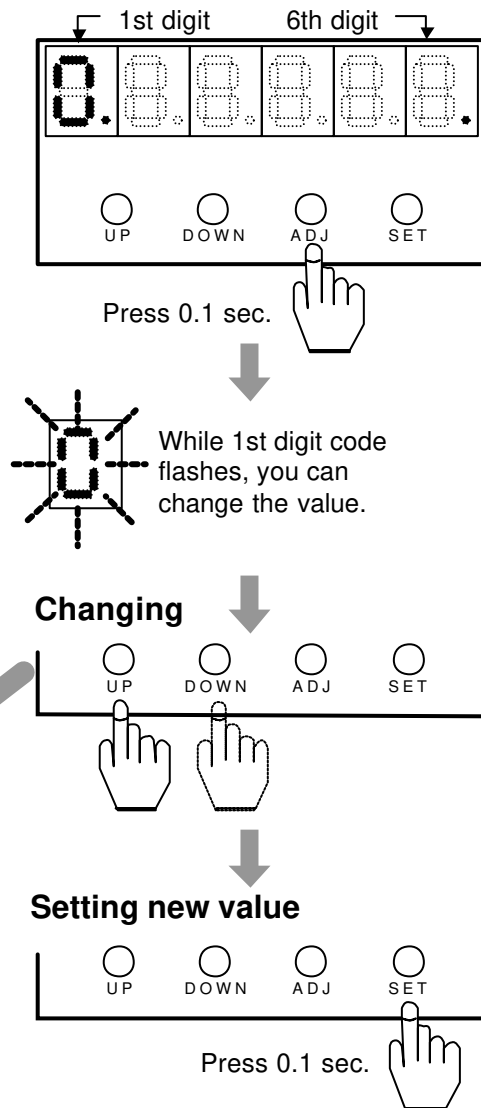

6-5-2 Functions of the tune mode



Speed loop gain

(position / speed mode)

• Function

The HA-655 drivers make actuators follow command signals precisely by triple feedback loops of position, speed, and current. The [speed loop gain] adjusts the proportional gain of the speed feedback loop. The relation between the gain and actuator motion is as follows:

High gain ⇒ obtains high servo stiffness and high response.

Excessive gain makes the servo system unstable, hunting, and a tendency to overshoot.

Low gain ⇒ Inadequate gain makes the servo system subject to undershooting.

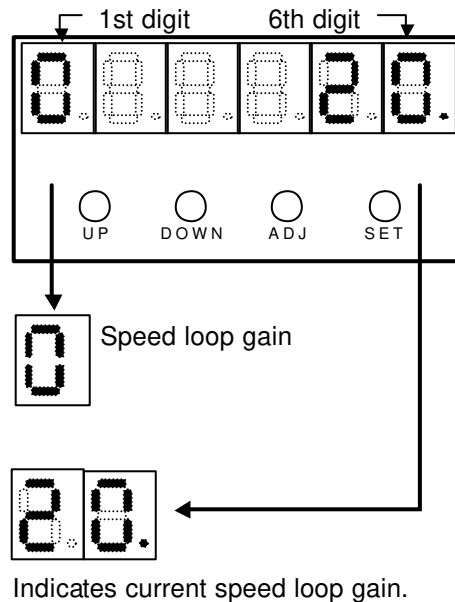
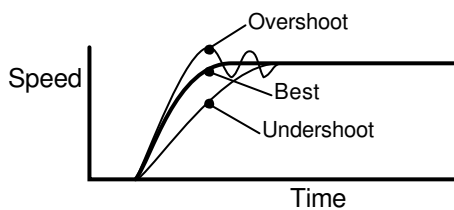

Set the highest gain within the limits of no hunting, no overshooting nor undershooting by a step command.

• Details of display

1st digit: [0: speed loop gain]

2nd to 6th digit: Indicates the current [speed loop gain]. An integer from [1] to [9999] can be set.

• Operations

- (1) To change a value, press the [ADJ] key at least 0.1 second.
⇒ 1st digit [0] flashes. You can change the value.
- (2) If the actuator is hunting or takes a long time for its speed to settle after a step command, then press the [DOWN] key to set a lower level.
If the actuator takes a long time for its speed after a step command, then press the [UP] key to set a higher level.
- (3) To define the new value, press the [SET] key at least 0.1 second.
⇒ Flashing of 1st digit [0] stops and the new value is defined.
- (4) To cancel a change in operation, press the [ADJ] key at least 0.1 second.
⇒ Flashing of 1st digit [0] stops and the previous value is restored.

• Related functions

[Speed loop integral compensation]: [tune mode] → [1: Speed loop integral compensation]

[Position loop gain]: [tune mode] → [2: position loop gain]

[Feed forward gain]: [tune mode] → [3: Feed forward gain]

[Tune mode]



Speed loop integral compensation (pos./spd.)

• Function

The HA-655 driver is equipped with a [Speed loop integral compensation] function to make speed fluctuation minimal against load torque variation. The relation between the gain and actuator motion is as follows:

High gain ⇒ eliminates hunting and gives low response to load torque variation.

Low gain ⇒ high response to load torque variation, excessive gain makes the servo system hunt.

• Details of display

1st digit: [0:Speed loop integral compensation]

2nd to 6th digit: Indicates the current [Speed loop integral compensation]. A value from [1] to [9999] can be set.

• Operations

- (1) To change a value, press the [ADJ] key at least 0.1 second.
⇒ 1st digit [1] flashes. You can change the value.
- (2) When the actuator does hunting, press the [DOWN] key to set a lower value.
When the response is low to load torque variation, press the [UP] key to set a higher value.
- (3) To define the new value, press the [SET] key at least 0.1 second.
⇒ Flashing of 1st digit [1] stops and the new value is defined.
- (4) To cancel a change in operation, press the [ADJ] key at least 0.1 second.
⇒ Flashing of 1st digit [1] stops and the previous value becomes effective.

• Related functions

[Speed loop gain]: [tune mode] → [0:Speed loop gain]

[Position loop gain]: [tune mode] → [2:position loop gain]

[Feed forward gain]: [tune mode] → [3:Feed forward gain]

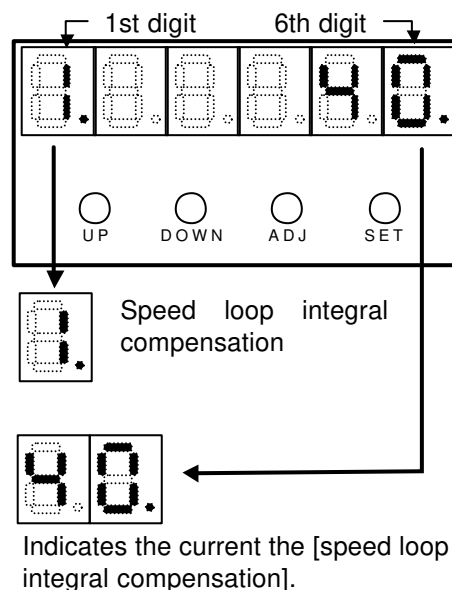

[Tune mode]



Position loop gain (position / speed mode)

• Function

The HA-655 driver is equipped with triple feedback loops of position, speed and current to make actuator motion follow position command precisely. The [position loop gain] adjusts proportional gain of feedback loop gain. The relation between the gain and actuator motion is as follows:

- High gain ⇒ obtains small position and following error.
Excessive gain makes the servo system unstable and causes it to hunt.
- Low gain ⇒ Inadequate gain results in a large following error to command signal.

Set the highest gain within the limits of no hunting, no overshooting nor undershooting by a step command.

• Details of display

- 1st digit: [2: position loop gain]
- 2nd to 6th digit: Indicates current [position loop gain]. A value from [10] to [9999] can be set.

• Operations

- (1) To change a value, press the [ADJ] key at least 0.1 second.
⇒ 1st digit [2] flashes. You can change the value.
- (2) When the actuator does hunting, press the [DOWN] key to set a lower value.
When the position following a command is poor, press the [UP] key to set a higher value.
- (3) To define a new value, press the [SET] key at least 0.1 second.
⇒ Flashing of 1st digit [2] stops and the new value is defined.
- (4) To cancel a change in operation, press the [ADJ] key at least 0.1 second.
⇒ Flashing of 1st digit [2] stops and the previous value becomes effective.

• Related functions

- [Speed loop gain]: [tune mode] → [0:Speed loop gain]
- [Speed loop integral compensation]: [tune mode] → [1:Speed loop integral compensation]
- [Feed forward gain]: [tune mode] → [3:Feed forward gain]

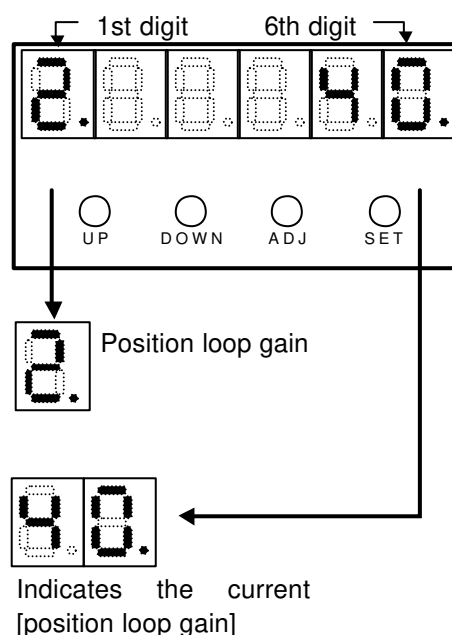

[Tune mode]

3. Feed forward gain (position mode)

• Function

In the position mode the HA-655 driver controls the error count, the difference between [command pulse] and [feedback pulse], to be [0]. At the beginning of inputting a command pulse train, the actuator starts slowly because of a small error count.

The [feed forward] function may accelerate the actuator as much as possible, adding the speed commands to the speed control loop. The speed commands are converted from a command pulse frequency (feed forward rate = 100%). The feed forward function provides acceleration control, minimizing the position error. The effects of the feed forward are disabled when the feed forward rate equals 0%.

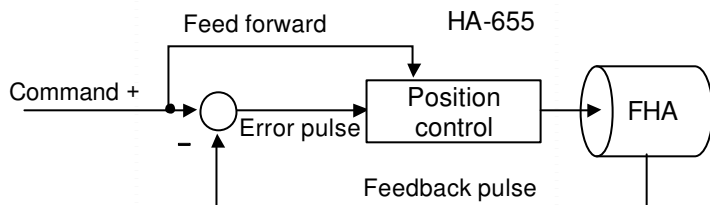

The relation between the gain and actuator motion is as follows:
Excessive gain causes mechanical shock and hunting.

• Details of display

1st digit: [3:Feed forward gain]

2nd to 3rd digit: No indication

4th to 6th digit: indicates current [Feed forward gain]. A value from [0] to [100] can be set.

• Operations

- (1) To change a value, press the [ADJ] key at least 0.1 second.
⇒ 1st digit [3] flashes. You can change the value.
- (2) When the actuator does hunting or mechanical shock occurs, press the [DOWN] key and set a lower value. When the position following to command is poor, press the [UP] key to set a higher value.
- (3) To define the new value, press the [SET] key at least 0.1 second.
⇒ Flashing of 1st digit [3] stops and the new value is defined.
- (4) To cancel a change in operation, press the [ADJ] key at least 0.1 second.
⇒ Flashing of 1st digit [3] stops and the previous value becomes effective.

• Related functions

[Speed loop gain]: [tune mode] → [0:Speed loop gain]

[Speed loop integral compensation]: [tune mode] → [1:Speed loop integral compensation]

[Position loop gain]: [tune mode] → [2:Position loop gain]

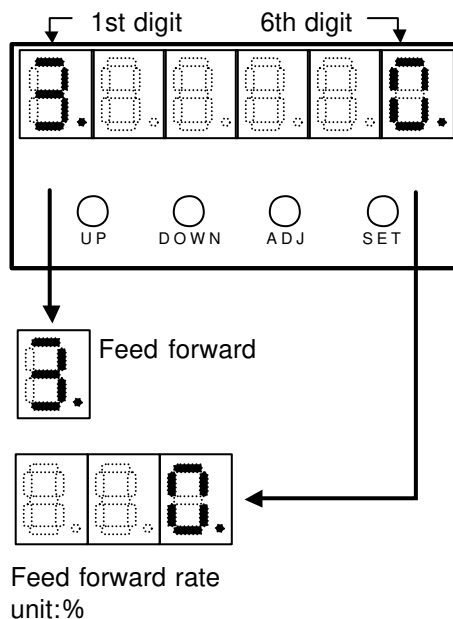

[Tune mode]



In-position range

(position mode)

Function

[In-position: INPOS (CN2-33 pin)] signal is outputted when an error count becomes less than the value of [in-position range]. The error count is the difference between [command pulse count] and [feedback pulse count],

Details of display

1st digit: [4: in-position range]

2nd digit: No indication

3rd to 6th digit: indicates the current [in-position range]. A value from [0] to [9999] can be set.

Operations

- (1) To change a value, press the [ADJ] key at least 0.1 second.
⇒ 1st digit [4] flashes. You can change the value.
- (2) To make [in-position range] narrow, press the [DOWN] key to set a lower value.
To make it wide, press the [UP] key to set a higher value.
- (3) To define the new value, press the [SET] key at least 0.1 second.
⇒ Flashing of 1st digit [4] stops and the new value is defined.
- (4) To cancel a change in operation, press the [ADJ] key at least 0.1 second.
⇒ Flashing of 1st digit [4] stops and the previous value becomes effective.

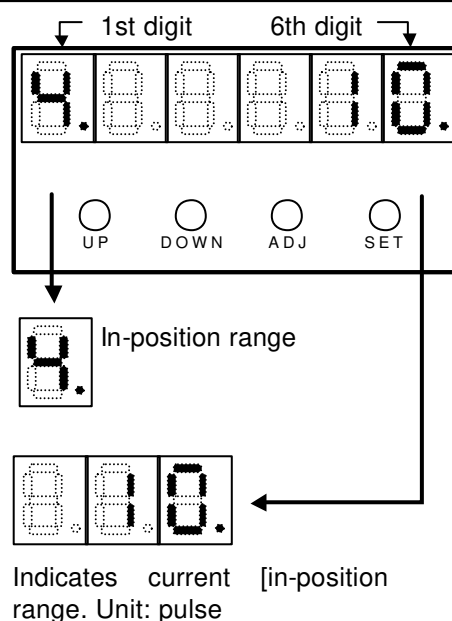

Attained speed

(speed mode)

Function

[Attained speed: HISPDP (CN2-33 pin)] signal is outputted when the actuator speed is more than the value of [attained speed].

Details of display

1st digit: [5:attained speed]

2nd digit: No indication

3rd to 6th digit: Indicates the current [attained speed]. A value from [0] to [9999] can be set.

Operations

- (1) To change a value, press the [ADJ] key at least 0.1 second.
⇒ 1st digit [5] flashes. You can change the value.
- (2) To make [attained speed] low, press the [DOWN] key to set a lower value.
To make it high, press the [UP] key to set a higher value.
- (3) To define the new value, press the [SET] key at least 0.1 second.
⇒ Flashing of 1st digit [5] stops and the new value is defined.
- (4) To cancel a change in operation, press the [ADJ] key at least 0.1 second.
⇒ Flashing of 1st digit [5] stops and the previous value becomes effective.

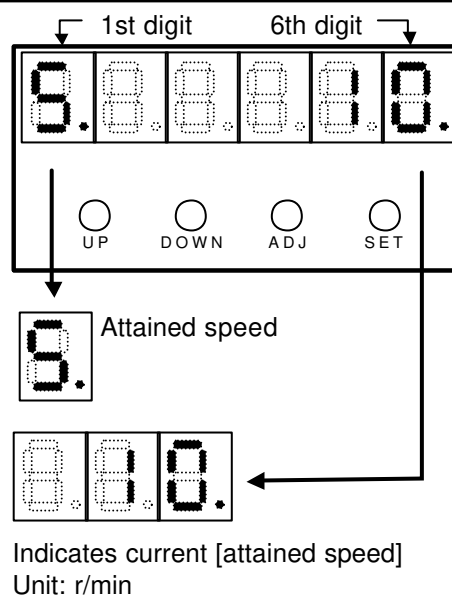

[Tune mode]



Internal speed command

(speed mode)

• Function

The function can operate the actuator without an external command. This is convenient for test operations without hosts and for system diagnosis.

Actuator motion at the interior speed starts with the input to [command change: CMD-CHG (CN2-6 pin)] and stops when input is OFF.

• Details of display

1st digit: [6: Internal speed command]

2nd digit: No indication

3rd to 6th digit: Indicates the current [internal speed command] setting. Unit is r/min, and a value from [1] to [speed limit] can be set.

• Operations

- (1) To change a value, press the [ADJ] key at least 0.1 second.
⇒ 1st digit [6] flashes. You can change the value.
- (2) To make [internal speed command] lower, press the [DOWN] key to set a lower value.
To make it high, press the [UP] key to set a higher value.
- (3) To define the new value, press the [SET] key at least 0.1 second.
⇒ Flashing of 1st digit [6] stops and the new value is defined.
- (4) To cancel a change in operation, press the [ADJ] key at least 0.1 second.
⇒ Flashing of 1st digit [6] stops and the previous value becomes effective.

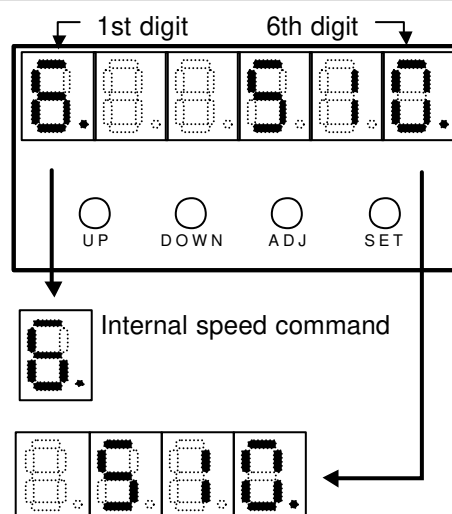

Indicates current [internal speed command].

Unit: r/min

Range: 1 to speed limit (Para.Mode A)

[Tune mode]



Acceleration time constant

(speed mode)

Function

[Acceleration time constant] is the time it takes to accelerate the motor from [0 r/min] to the speed of [A: speed limit] of [parameter mode].

The acceleration time to speed command voltage is as follows:

$$\text{Accel. time} = \text{Accel. time const} \times \frac{\text{Cmd voltage}}{\text{Speedlimit}} \times \frac{\text{Spd conversion factor}}{10}$$

Details of display

1st digit: [7: Acceleration time constant]

2nd to 3rd digit: No indication

4th to 6th digit: Indicates current [Acceleration time constant], unit and a value from [0] to [9999] ms can be set.

Operations

(1) To change a value, press the [ADJ] key at least 0.1 second.

⇒ 1st digit [7] flashes. You can change the value.

(2) To make [acceleration time constant] low, press the [DOWN] key to set a lower value. To make it higher, press the [UP] key to set a higher value.

(3) To define the new value, press the [SET] key at least 0.1 second.

⇒ Flashing of 1st digit [7] stops and the new value is defined.

(4) To cancel a change in operation, press the [ADJ] key at least 0.1 second.

⇒ Flashing of 1st digit [7] stops and the previous value becomes effective.

Related functions

[Speed limit]: [Parameter mode] → [A: Speed limit]

[Speed conversion factor]: [Parameter mode] → [9: Speed conversion factor]

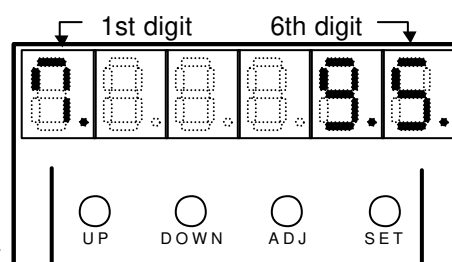

Acceleration time constant

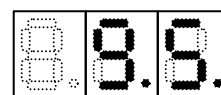

Indicates current [acceleration time constant]. Unit: millisecond

Range: 0 to 9999 ms



Deceleration time constant

(speed mode)

Function

[Deceleration time constant] is the time it takes to decelerate the motor from the speed of [A: speed limit] of [parameter mode] to [0 r/min]. The deceleration time to speed command voltage is as follows:

$$\text{Decel time} = \text{Decel time const} \times \frac{\text{Cmd voltage}}{\text{Speedlimit}} \times \frac{\text{Spd conversion factor}}{10}$$

Details of display

1st digit: [8: Deceleration time constant]

2nd to 3rd digit: No indication

4th to 6th digit: Indicates current [Deceleration time constant], unit and a value from [0] to [9999] ms can be set.

Operations

Same operations as [acceleration time constant]

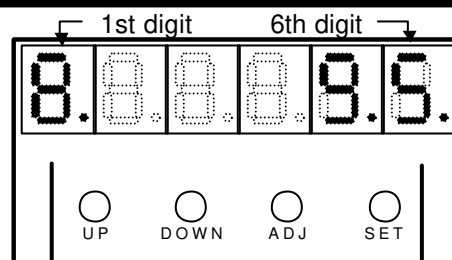

Deceleration time constant

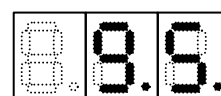

Indicates current [deceleration time constant]. Unit: millisecond

Range: 9999 ms

[Tune mode]

9.

Speed command offset

(speed mode)

• Function

In the speed mode, motor may rotate slightly in spite of [0V] speed command voltage. This problem may occur when the speed command voltage has an offset of a few milli-volt. This function removes the slight rotation by the command voltage offset.

Search for a proper offset value by inputting [0V] of command voltage not to rotate the motor that changes the value.

• Details of display

1st digit: [9: Speed command offset]

2nd to 3rd digit: No indication

4th to 6th digit: Indicates current [Speed command offset] [-9999] to [9999] can be set.

• Operations

- (1) To change a value, press the [ADJ] key at least 0.1 second.
⇒ 1st digit [9] flashes. You can change the value.
- (2) Set speed command voltage on [0V].
- (3) Increase or decrease the [speed command offset] until the motor stops.
To increase it, press the [DOWN] key to set a lower value.
To decrease it, press the [UP] key to set a higher value.
- (4) To define the new value, press the [SET] key at least 0.1 second.
⇒ Flashing of 1st digit [9] stops and the new value is defined.
- (5) To cancel a change in operation, press the [ADJ] key at least 0.1 second.
⇒ Flashing of 1st digit [9] stops and the previous value becomes effective.

• Related functions

[Speed command auto. offset]: [Test mode] → [Speed command auto. offset]

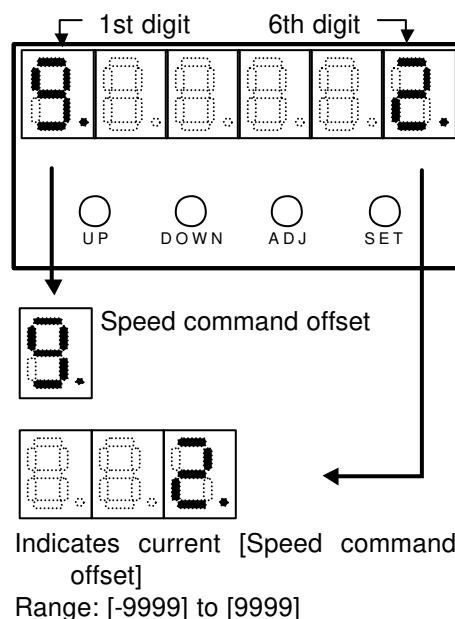

8.8.8.

End of tune mode

• Function

This terminates the [tune mode] and returns to the [monitor mode]. Indicating [End] and pressing the [SET] key returns to the [monitor mode].

• Details of display

1st to 3rd digit: No indication

4th to 6th digit: Indicates [End]

• Operations

- (1) To terminate the [tune mode] and to return to the [monitor mode], press the [SET] with the [End] indicated.
⇒ The indication mode returns to the [monitor mode].

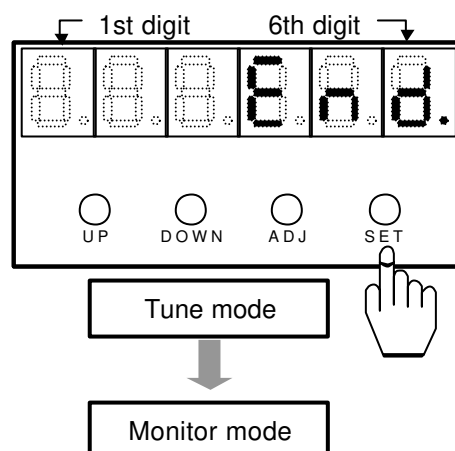

6-6 Parameter mode

The [parameter mode] sets various parameter values relating to the fundamental operational functions such as: specifications of [position mode] or [speed mode], configurations of input signals, electronic gear function, limiting values of speed and torque, and parameters to communicate with a host.

The parameter mode indicates and sets the following items.

Mode	Code	Position mode	Setting	Code	Speed mode	Setting
Parameter mode	0	Control mode	Possible	0	Control mode	Possible
	1	Command configuration		1	----	----
	2	Multiplication of 2-phase pulse		2	----	----
	3	Electronic gear - denominator		3	----	----
	4	Electronic gear - numerator		4	----	----
	5	Error count cleared by S-ON		5	----	----
	6	Position error allowance		6	----	----
	7	----	----	7	Zero clamp	Possible
	8	Rotary direction	8	Rotary direction		
	9	Speed conversion factor	9	Speed conversion factor		
	A	Speed limit	A	Speed limit		
	b	Torque limit	b	Torque limit		
	c	Alarm logic	c	Alarm logic		
	d	----	----	d	----	----
	E	----	----	E	----	----
F	ABS multi-turn data clear	Impossible	F	ABS multi-turn data clear	Impossible	

6-6-1 Operating in the parameter mode

- **Selecting operations of function items**

(1) To transfer to [parameter mode] from [monitor mode], press both the [ADJ] key and the [SET] key at the same time at least three seconds.

⇒ Transfers to [parameter mode] when there is no indication on 4th to 6th digit.

(Note): While [servo-ON: S-ON (CN2-3 pin)] signal is ON, changing to [parameter mode] turns the signal OFF and the system goes into the servo-OFF state.

(2) Press the [UP] key or the [DOWN] key to change the functional items of [parameter mode]

⇒ Every pressing the [UP] key shifts a code of the first digit one by one from [0] to [b], and indicates a value corresponding to the code.

⇒ Every pressing the [DOWN] key shifts a code of the first digit one by one from [b] to [0], and indicates a value corresponding to the code.

- **Function**

(1) Transferring to the parameter mode:

1st to 3rd digit: indicates [SyP].

4th to 6th digit: Indicates [-] throughout the transfer.

(2) For the parameter mode:

1st digit: Codes in the mode

2nd to 6th digit: A value of the code

Decimal point of the second digit: indicates that the state is in the parameter mode.

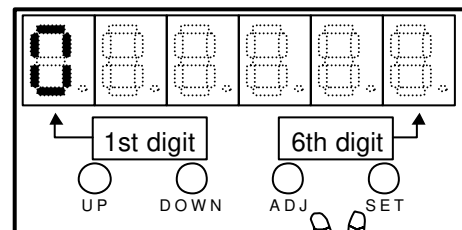

Monitor mode

Press both 3 sec.

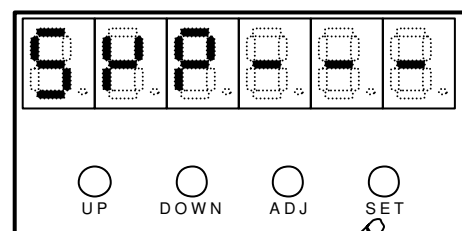

Parameter mode

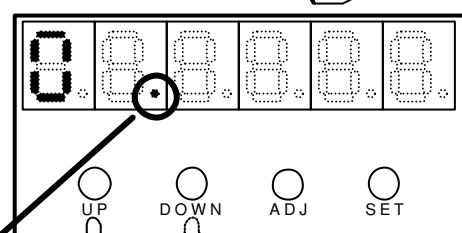

Selecting a function

• **Operations of values**

- (1) To change a value, press the [ADJ] key at least 0.1 second.
⇒ 1st digit [0] flashes. You can change the value.
- (2) Change the value with the keys of [UP] and [DOWN].
The [UP] key increases the value.
The [DOWN] key decreases the value.
- (3) To define the new value, press the [SET] key at least 0.1 second.
⇒ The value is stored in the memory. From now on, the new value is effective.
- (4) To cancel a change in operation and to make the previous value effective before defining, press the [ADJ] key at least 0.1 second.
⇒ The previous value becomes effective.

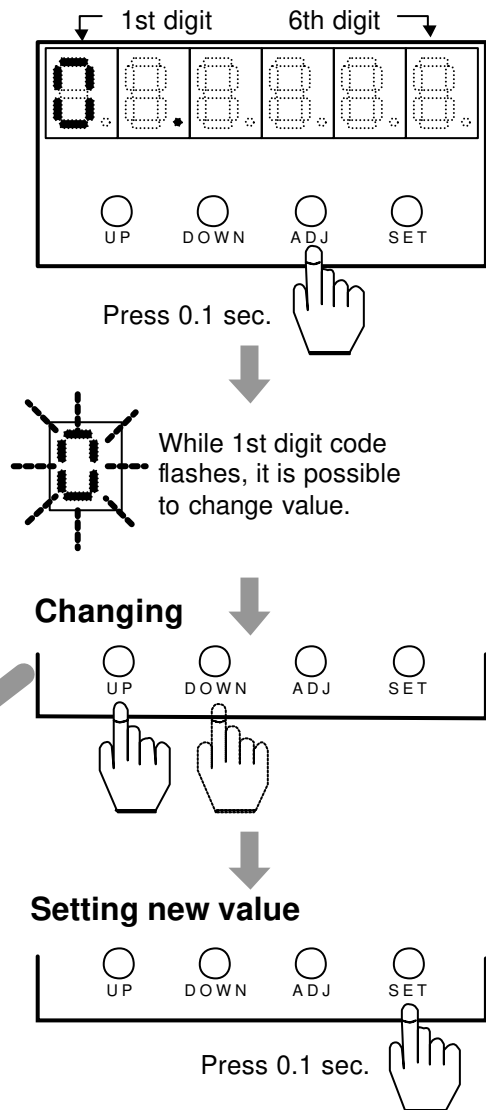

6-6-2 Functions of the parameter mode



Control mode

(position / speed mode)

- **Function**

The HA-655 driver can control the actuator in either the [position mode] or the [speed mode]. This function selects an operating mode.

In the position mode a command signal is composed of pulse trains, while in the speed mode it is composed of an analog voltage.

- **Details of display**

1st digit: [0:Control mode]

2nd to 5th digit: No indication

6th digit: [0]: position mode (factory default)
[1]: speed mode

- **Operations**

- (1) To change a value, press the [ADJ] key at least 0.1 second.
⇒ 1st digit [0] flashes. You can change the value.
- (2) To set [position mode], set [0] by the [DOWN] key.
To set [speed mode], set [1] by the [UP] key.
- (3) To define the new value, press the [SET] key at least 0.1 second.
⇒ Flashing of 1st digit [0] stops and the new value is defined.
- (4) To cancel a change in operation, press the [ADJ] key at least 0.1 second.
⇒ Flashing of 1st digit [0] stops and the previous value becomes effective.

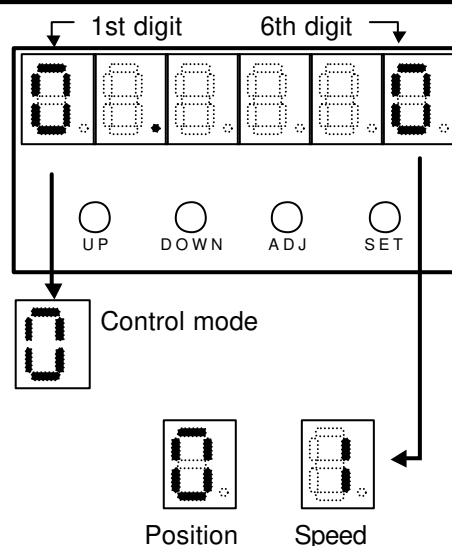

[Parameter mode]



Command configuration

(position mode)

• Function

Three types of command signals can be inputted to the HA-655 driver as follows:

Type	2-pulse train	1-pulse train	2-phase pulse
Code	0	1	2
Command configuration	Forward 	Forward 	Forward
	Reverse 	Reverse 	Reverse
FWD CN2-27,28	Forward	Pulse train	Phase-A
REV CN2-29,30	Reverse	Polarity	Phase-B
Setting	Factory default		

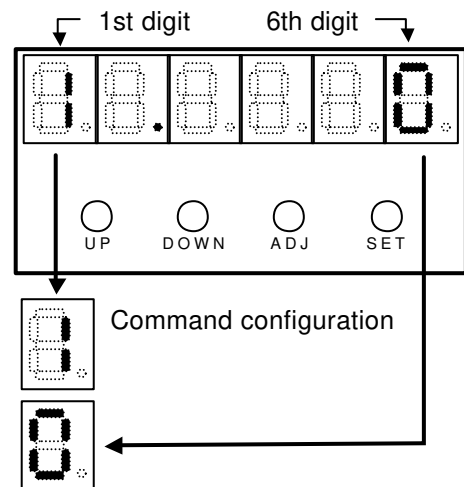

Indicates current command configuration.
 0: 2-pulse train
 1: 1-pulse train
 2: 2-phase pulse

• Details of display

1st digit: [1: command configuration].

2nd to 5th digit: No indication

6th digit: Indicates current [command configuration] code (refer above table).

• Operations

- (1) To change a value, press the [ADJ] key at least 0.1 second.
 ⇒ 1st digit [1] flashes. You can change the value.
- (2) Set a code to [command configuration] with the [UP] or [DOWN] key.
- (3) To define the new value, press the [SET] key at least 0.1 second.
 ⇒ Flashing of 1st digit [1] stops and the new value is defined.
- (4) To cancel a change in operation, press the [ADJ] key at least 0.1 second.
 ⇒ Flashing of 1st digit [1] stops and the previous value becomes effective.



Multiplication of 2-phase pulse

(position mode)

• Function

When [command configuration] is set at [2-phase pulse], it is possible to make the motion command pulse count two or four times greater than the command pulse count.

- 1: Same as the command count
- 2: Two times the command count
- 4: Four times the command count

• Details of display

1st digit: [2: Multiplication of 2-phase pulse]

2nd to 5th digit: No indication

6th digit: Indicates the current multiplier of [multiplication of 2-phase pulse] function.
 [1], [2] and [4] are allowed.

• Operations

Same operations as [command configuration] described above

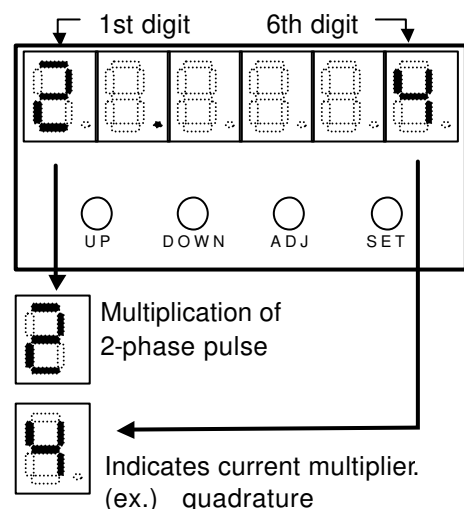

Indicates current multiplier.
 (ex.) quadrature

[Parameter mode]

3.**Electronic gear-denominator (position mode)****• Function**

This is used in conjunction with [4: electronic gear-numerator] as an electronic gear function that is used when it is required to make a relationship between a displacement of the driven mechanism an integer number of command pulses.

The relation of [denominator/numerator] is as follows:

◆ For rotary motion:

$$\frac{\text{Electronic gear - denominator}}{\text{Electronic gear - numerator}} = \frac{\text{Angular displacement for pulse}}{\text{Reduction ratio of mechanism}} \times \text{Actuator resolution} \times \frac{1}{360}$$

◆ For linear motion:

$$\frac{\text{Electronic gear - denominator}}{\text{Electronic gear - numerator}} = \frac{\text{Linear displacement for pulse}}{\text{Feeding pitch of mechanism}} \times \text{Actuator resolution}$$

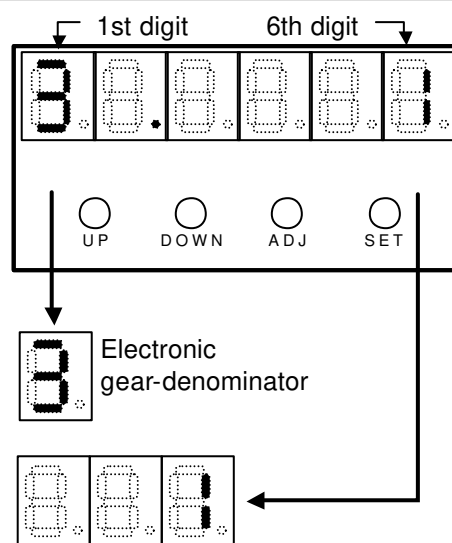

Indicates current the [Electronic gear-denominator].
Range: 1-50

Determine integers for both the denominator and the numerator.

• Details of display

1st digit: [3: Electronic gear-denominator]

2nd to 4th digit: No indication

5th to 6th digit: Indicates the current [Electronic gear-denominator]. A value from [1] to [50] can be set.

• Operations

- (1) To change a value, press the [ADJ] key at least 0.1 second.
⇒ 1st digit [3] flashes. You can change the value.
- (2) Set a value to [electronic gear-denominator] with the keys of [UP] and [DOWN].
- (3) To define the new value, press the [SET] key at least 0.1 second.
⇒ Flashing of 1st digit [3] stops and the new value is defined.
- (4) To cancel a change in operation, press the [ADJ] key at least 0.1 second.
⇒ Flashing of 1st digit [3] stops and the previous value becomes effective.

4.**Electronic gear-numerator (position mode)****• Function**

This is used with [3: electronic gear-denominator] as electronic gear function.

Refer [3: electronic gear-denominator] for the details.

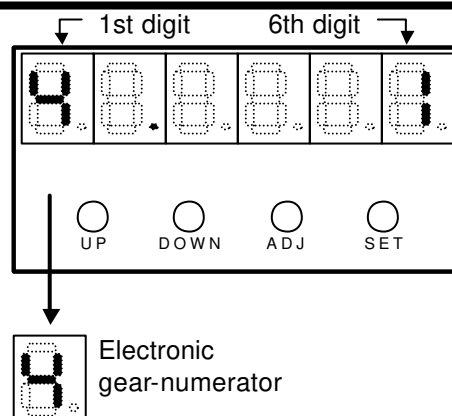

[Parameter mode]



Error count cleared by S-ON

(position mode)

• Function

Even when the servo power is OFF, the control power is still ON. If the position of the load mechanism shifts due to gravity or manual force while the servo power is OFF, the error count changes. If the servo power is turned ON, the actuator rotates rapidly to make the error count return to [0].

This rapid motion may be dangerous. The S-ON function allows the error count to be reset to [0] when the servo power is turned on. Thus, the actuator will not move when the servo power is restored. However, the position error data is lost and the actuator will not return to its original position.

• Details of display

1st digit: [5: error count cleared by S-ON]
 2nd to 5th digit: No indication
 6th digit: indicates current setting of [error count cleared by S-ON].
 [0]: not cleared
 [1]: cleared

• Operations

- (1) To change a value, press the [ADJ] key at least 0.1 second.
 ⇒ 1st digit [5] flashes. You can change the value
- (2) Set [0] (not cleared) by the [DOWN] key, or set [1] (cleared) by [UP] key.
- (3) To define the new value, press the [SET] key at least 0.1 second.
 ⇒ Flashing of 1st digit [5] stops and the new value is defined.
- (4) To cancel a change in operation, press the [ADJ] key at least 0.1 second.
 ⇒ Flashing of 1st digit [5] stops and the previous value becomes effective.

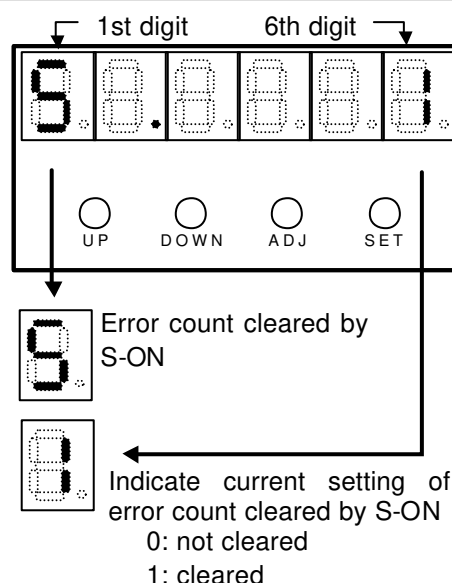

[Parameter mode]



Position error allowance

(position mode)

Function

The [error counter] calculates [error count] subtracting the [feedback count] from the [position command]. A large position error may result in an abnormality.

When the position error exceeds the [position error allowance], an [alarm 60] occurs and the servo power shuts off.

Details of display

1st digit: [6: position error allowance]

2nd digit: No indication

3rd to 6th digit: Indicates the current [position error allowance]. A value from [1] to [1000] can be set.

Operations

- (1) To change a value, press the [ADJ] key at least 0.1 second.
⇒ 1st digit [6] flashes. You can change the value.
- (2) To make the allowance narrow, press the [DOWN] key.
To make it wide, press the [UP] key.
- (3) To define the new value, press the [SET] key at least 0.1 second.
⇒ Flashing of 1st digit [6] stops and the new value is defined.
- (4) To cancel a change in operation, press the [ADJ] key at least 0.1 second.
⇒ Flashing of 1st digit [6] stops and the previous value becomes effective.

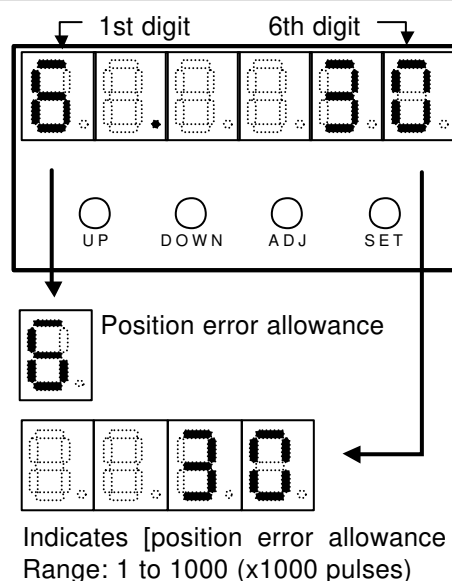

Zero clamp

(speed mode)

Function

In the speed mode when the [speed command] is [0], the actuator may rotate slightly by force from the drive mechanism. The [Zero clamp] function forcefully stops actuator when the speed command is [0].

Details of display

1st digit: [7: Zero clamp]

2nd to 5th digit: No indication

6th digit: Indicates current setting of [zero clamp] function.

[0]: Zero clamp OFF; [1]: Zero clamp ON

Operations

- (1) To change a value, press the [ADJ] key at least 0.1 second.
⇒ 1st digit [7] flashes. You can change the value.
- (2) By the keys of [UP] and [DOWN], set [0] (no function) or [1] (zero clamp).
- (3) To define the new value, press the [SET] key at least 0.1 second.
⇒ Flashing of 1st digit [7] stops and the new value is defined.
- (4) To cancel a change in operation, press the [ADJ] key at least 0.1 second.
⇒ Flashing of 1st digit [7] stops and the previous value becomes effective.

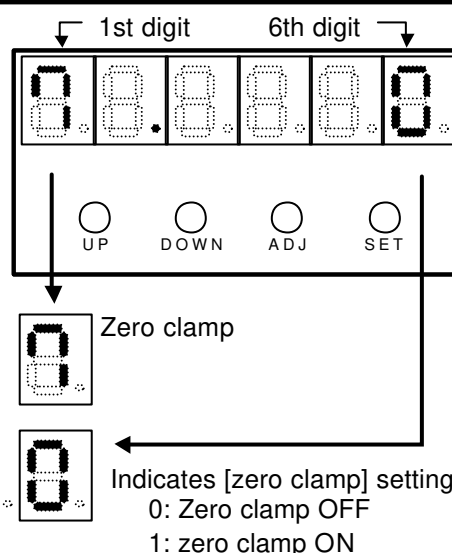

[Parameter mode]

8

Rotary direction

(position / speed mode)

• Function

This function specifies the rotary direction of the actuator when responding to commands.

The relation among them is as follows:

Value	FWD command	REV command	Setting
0	FWD rotation	REV rotation	Default
1	REV rotation	FWD rotation	

• Details of display

1st digit: [8: rotary direction]

2nd to 5th digit: No indication

6th digit: Indicates current [rotary direction] setting.

• Operations

- To change a value, press the [ADJ] key at least 0.1 second.
⇒ 1st digit [8] flashes. You can change the value.
- Set [0] or [1] pressing the [UP] key or the [DOWN] key, referring above table.
- To define the new value, press the [SET] key at least 0.1 second.
⇒ Flashing of 1st digit [8] stops and the new value is defined.
- To cancel a change in operation, press the [ADJ] key at least 0.1 second.
⇒ Flashing of 1st digit [8] stops and the previous value becomes effective.

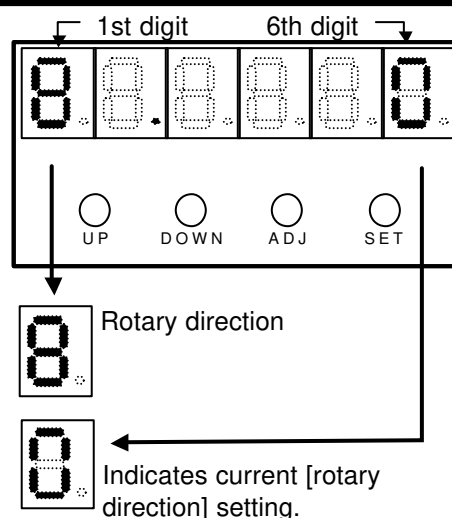

9

Speed conversion factor (position / speed mode)

• Function

This factor defines the motor speed corresponding to a [10V] of command voltage. The relation between the command voltage and the actuator speed is as follows:

$$\text{Motor speed} = \text{Command voltage} \times \frac{\text{Speed conversion factor}}{10.0\text{V}}$$

[Speed monitor (SPD-MON: CN2-23pin)] outputs the voltage calculated by the following formula:

$$\text{Speed monitor voltage} = \text{Speed} \times \frac{10.0\text{V}}{\text{Speed conversion factor}}$$

• Details of display

1st digit: [9: speed conversion factor]

2nd digit: No indication

3rd to 6th digit: Indicates current [speed conversion factor]. A value from [1] to [motor max. speed] can be set.

• Operations

- To change a value, press the [ADJ] key at least 0.1 second.
⇒ 1st digit [9] flashes. You can change the value.
- Set the motor speed corresponding to command voltage of [10V] by the keys of [UP] and [DOWN].
- To define the new value, press the [SET] key at least 0.1 second.
⇒ Flashing of 1st digit [9] stops and the new value is defined.
- To cancel a change in operation, press the [ADJ] key at least 0.1 second.
⇒ Flashing of 1st digit [9] stops and the previous value becomes effective.

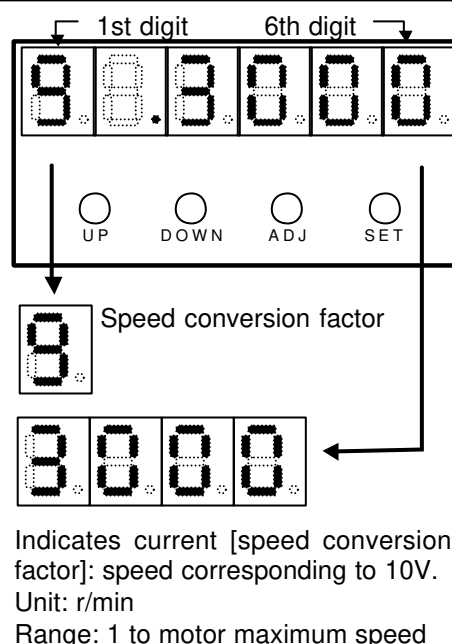

[Parameter mode]



Speed limit

(position / speed mode)

• Function

This function limits motor speed to protect the motor and driven mechanism.

• Details of display

1st digit: [A: speed limit]

2nd digit: No indication

3rd to 6th digit: Indicates current [speed limit]. A value from [1] to [motor max. speed] can be set.

• Operations

- (1) To change a value, press the [ADJ] key at least 0.1 second.
⇒ 1st digit [A] flashes. You can change the value.
- (2) Set a value to [speed limit] by the keys of [UP] and [DOWN].
- (3) To define the new value, press the [SET] key at least 0.1 second.
⇒ Flashing of 1st digit [A] stops and the new value is defined.
- (4) To cancel a change in operation, press the [ADJ] key at least 0.1 second.
⇒ Flashing of 1st digit [A] stops and the previous value becomes effective.

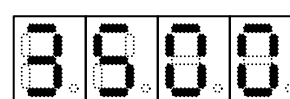
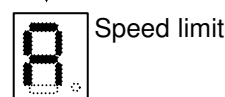
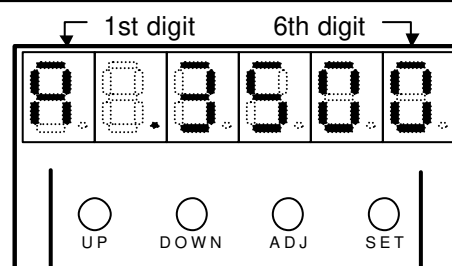

Indicates [speed limit].
Unit: r/min
Range: 1 to motor max. speed



Torque limit

(position / speed mode)

• Function

This function limits motor torque to protect the motor and driven mechanism. The maximum motor torque corresponds to 100%.

• Details of display

1st digit: [b:torque limit]

2nd to 3rd digit: No indication

4th to 6th digit: Indicates current [torque limit]. A value from [1] to [100] can be set.

• Operations

- (1) To change a value, press the [ADJ] key at least 0.1 second.
⇒ 1st digit [b] flashes. You can change the value.
- (2) Set a value to [torque limit] with the keys of [UP] and [DOWN].
- (3) To define the new value, press the [SET] key at least 0.1 second.
⇒ Flashing of 1st digit [b] stops and the new value is defined.
- (4) To cancel a change in operation, press the [ADJ] key at least 0.1 second.
⇒ Flashing of 1st digit [b] stops and the previous value becomes effective.

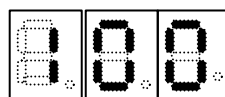
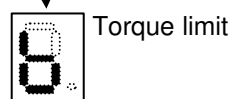
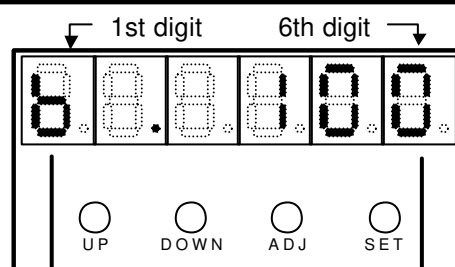

Indicates current torque limit; Range: 1 to 100%

[Parameter mode]



Alarm logic

(position / speed mode)

• Function

The alarm signal logic (normal open / normal close) is defined as follows:

Value	Logic	Setting
0	Normal close (NC)	Factory default
1	Normal open (NO)	

• Details of display

1st digit: [c: alarm logic]

2nd to 5th digit: No indication

6th digit: Indicates current [alarm logic] setting.

• Operations

- To change a value, press the [ADJ] key at least 0.1 second.
⇒ 1st digit [c] flashes. You can change the value.
- Set [0] or [1] with the keys of [UP] and [DOWN].
- To define the new value, press the [SET] key at least 0.1 second.
⇒ Flashing of 1st digit [c] stops and the new value is defined.
- To cancel a change in operation, press the [ADJ] key at least 0.1 second.
⇒ Flashing of 1st digit [c] stops and the previous value becomes effective.

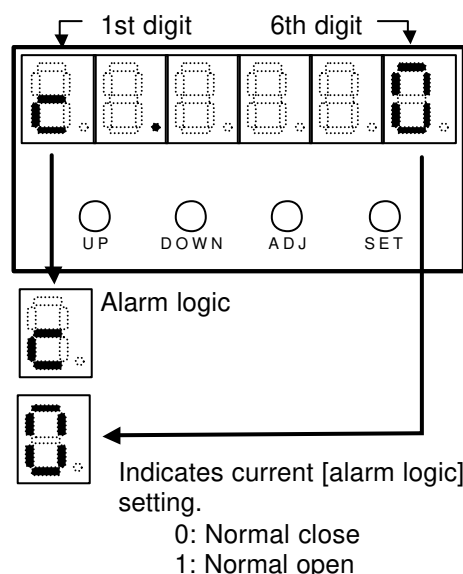

ABS multi-turn data clear

(position / speed mode)

• Function

This function clears data in the absolute multi-turn counter manually.

• Details of display

1st digit: [F: ABS multi-turn data clear]

2nd digit: No indication

3rd to 6th digit: Indicates time for absolute multi-turn data clear.

• Operations

- To change a value, press the [ADJ] key at least 0.1 second.
⇒ 1st digit [F] flashes. You can change the value.
- Press the [SET] key, then [2500] is indicated. Keeping the pressing more the value decreases to [0]. Then [clr] will indicated.
- Press the [SET] key at least 0.1 second following the [clr] indication.
⇒ Flashing of 1st digit [F] stops and the ABS multi-turn data are cleared.

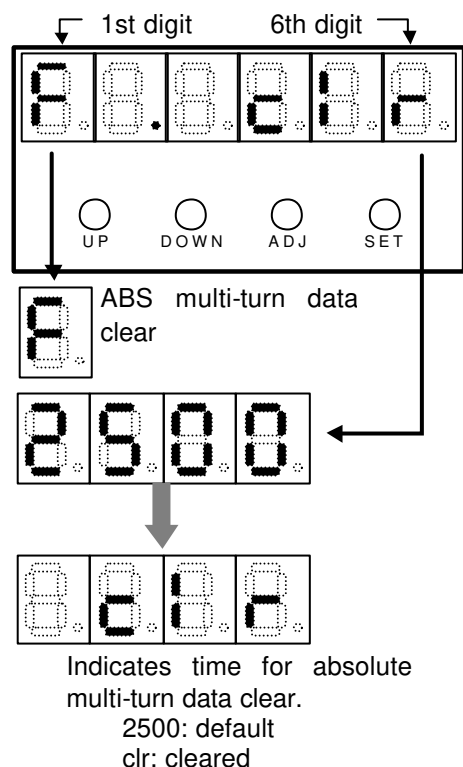

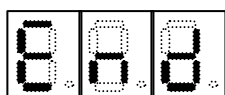

End of parameter mode

- **Function**

This terminates the [parameter mode] and returns to the [monitor mode]. Indicating [End] and pressing the [SET] key returns you to the [monitor mode].

- **Details of display**

1st to 3rd digit: No indication

4th to 6th digit: indicates [End].

- **Operations**

To terminate the [parameter mode] and to return to the [monitor mode], press the [SET] with [End] indicated.

⇒ The parameter mode returns to the [monitor mode].

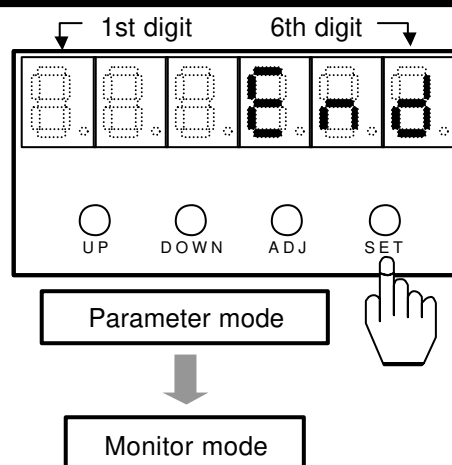

6-7 Test mode

The test mode consists of required functions for system test, such as JOG operation functions, operations of pseudo output signals, and I/O signal monitors.

The [test mode] indicates and operates the following items:

Mode	Code	Position mode	Setting	Code	Speed mode	Setting
Test mode	Jo	JOG operation	Possible	Jo	JOG operation	Possible
	SP	JOG speed	Possible	SP	JOG speed	Possible
	Ac	JOG acceleration		Ac	JOG acceleration	
	InP	Output port operation	Possible	InP	Output port operation	Possible
	c	I/O monitor	Impossible	c	I/O monitor	Impossible
	An	Analog monitor manual output	Possible	An	Analog monitor manual output	Possible
	So	Speed command auto-offset	Possible	So	Speed command auto-offset	Possible

6-7-1 Operating in the test mode

- **Selecting operations of function items**

(1) To transfer to the [test mode] from the [monitor mode], press the [SET] key at least three seconds.

⇒ Transfers to [test mode] when there is no indication on 4th to 6th digit.

(2) Press the [UP] or [DOWN] key to change the functional items of the [test mode]

⇒ Every pressing the [UP] key shifts a code of the first digit one by one from [Jo] to [So], and indicates a value corresponding to the code.

⇒ Every pressing the [DOWN] key shifts a code of the first digit one by one from [So] to [Jo], and indicates a value corresponding to the code.

- **Function**

(1) Transferring to the test mode:

1st to 3rd digit: indicates [TST].

4th to 6th digit: Indicates [-] throughout the transfer.

(2) For the test mode:

1st and 2nd digit: Codes in the mode

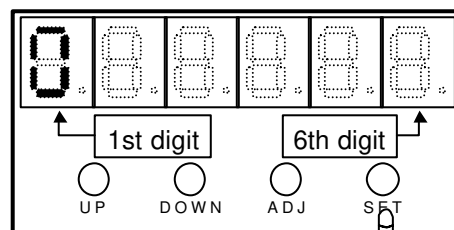

Monitor mode

Press 3 sec.

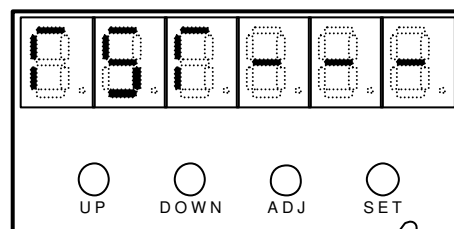

Test mode

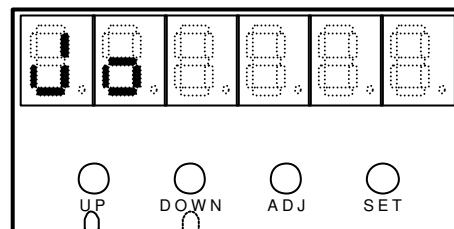

Selecting a function

• **Operations**

- (1) To change a value, press the [ADJ] key at least 0.1 second.
⇒ 1st digit [0] flashes. You can change the value.
- (2) Change the value with the keys of [UP] and [DOWN].
[UP] key increases the value.
[DOWN] key decreases the value.
- (3) To define the new value, press the [SET] key at least 0.1 second.
⇒ The value is stored in the memory. From now on, the new value is effective.
- (4) To cancel a change in operation and to make the previous value effective before defining, press the [ADJ] key at least 0.1 second.
⇒ The previous value becomes effective.

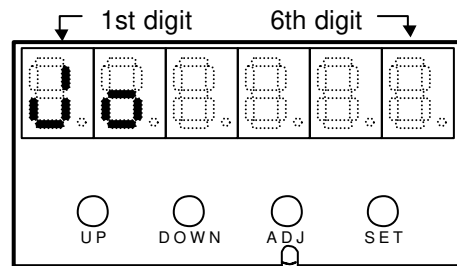

Press 0.1 sec.

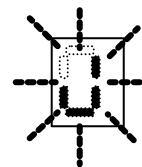

While 1st digit code flickers, it is possible to change value.

Changing

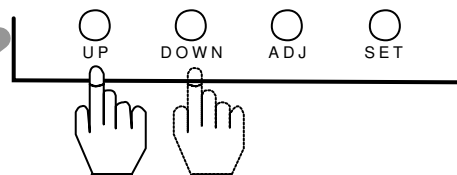

Canceling

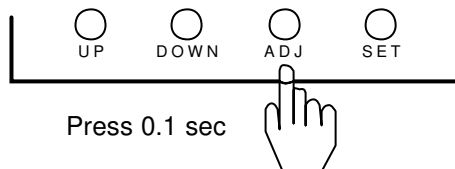

Press 0.1 sec

Setting new value



Press 0.1 sec

6-7-2 Functions of the test mode

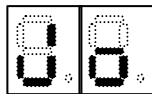

JOG operation

(position / speed mode)

- **Function**

Pressing [UP] or [DOWN] key rotates the motor with the speed of [1:JOG speed].

- **Details of display**

1st and 2nd digit: [Jo: JOG operation]

3rd to 6th digit: No indication

- **Operations**



Before JOG operation, make sure load conditions and motor/encoder cable installations are correct.

Activating JOG operation mode turns servo ON. Improper load and poor cable installation can result in accidents that may cause physical injury and fire.

- (1) To transfer to in [JOG operation] mode, Press the [ADJ] key at least 0.1 second.
 ⇒ 1st digit [J] flashes and servo turns ON.
 ⇒ JOG operation is available.
- (2) To operate the motor forward, press the [UP] key.
 ⇒ The motor will rotate when the key is pressed, and will stop when the key is left.
- (3) To operate the motor reverse, press the [DOWN] key.
 ⇒ The motor will rotate when the key is pressed, and will stop when the key is released.
- (4) To exit from [JOG operation] mode, press the [SET] key at least 0.1 second.
 ⇒ Flashing of 1st digit [J] stops, servo turns OFF, and [JOG operation] mode terminates.

- **Related functions**

[JOG speed]: [test mode] → [SP: JOG speed]

[JOG acceleration]: [test mode] → [Ac: JOG acceleration]

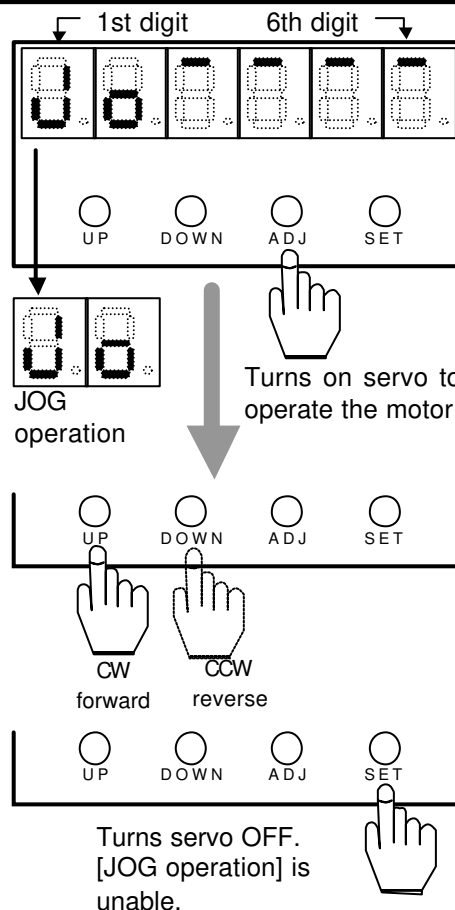

[Test mode]

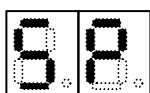

JOG speed

(position / speed mode)

• Function

The motor speed in [JOG operation] mode is set in [10r/min] increments. The unit is [r/min].

• Details of display

1st and 2nd digit: [SP: JOG speed]

3rd to 6th digit: [JOG speed]; unit: r/min

• Operations

- (1) To set [JOG speed], press the [ADJ] key at least 0.1second.
⇒ 1st digit [S] flashes. You can change the value.
- (2) To set [JOG speed] press the [UP] to increase the value, or [DOWN] key for decrease it.
- (3) To define the new value, press the [SET] key at least 0.1 second.
⇒ Flashing of 1st digit [S] stops and the new value is defined.
- (4) To cancel a change in operation, press the [ADJ] key at least 0.1 second.
⇒ Flashing of 1st digit [S] stops and the previous value becomes effective.

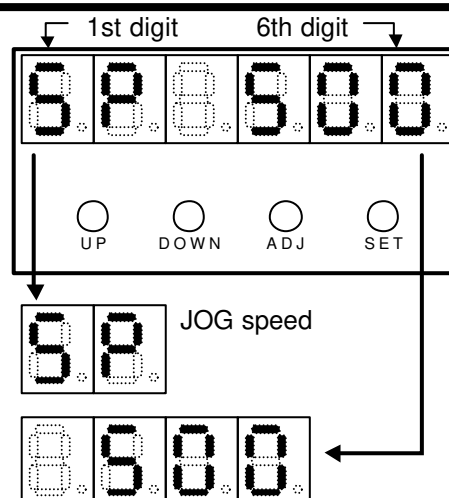

Indicates current [JOG speed].
Unit: r/min; 10r/min step
Range: 100 to motor max. speed

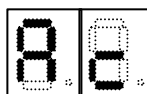

JOG acceleration

(position / speed mode)

• Function

The motor acceleration and deceleration in [JOG operation] mode is set by the accelerating time from [0] to [JOG speed] in [msec] unit.

• Details of display

1st and 2nd digit: [Ac: JOG acceleration]

3rd to 6th digit: [JOG accelerating time]; unit: msec

Operations

- (1) To set [JOG acceleration], press the [ADJ] key at least 0.1 second.
⇒ 1st digit [A] flashes. You can change the value.
- (2) To set [JOG acceleration] press the [UP] to increase the value, or [DOWN] key for decrease it.
- (3) To define the new value, press the [SET] key at least 0.1 second.
⇒ Flashing of 1st digit [A] stops and the new value is defined.
- (4) To cancel a change in operation, press the [ADJ] key at least 0.1 second.
⇒ Flashing of 1st digit [A] stops and the previous value becomes effective.

• Related functions

[JOG operation]: [test mode] → [Jo: JOG operation]

[JOG speed]: [test mode] → [SP: JOG speed]

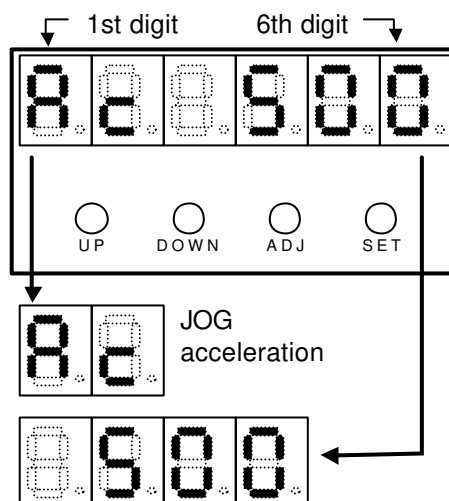

Indicates current [JOG acceleration]
Unit: msec

[Test mode]

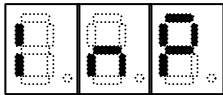

Output port operation (pos. / spd. mode)

- **Function**

It is possible to operate turn (ON/OFF) output ports manually.

- **Details of display**

1st to 3rd digit: indicates the code for the output port.

4th to 6th digit: indicates current state of the port.

- **Operations**

- (1) To operate output ports, press the [ADJ] key at least 0.1 second.

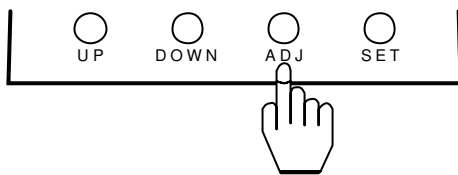

⇒ 1st digit flashes. You can operate output ports.

(Pressing the [ADJ] key at least 0.1 second again inhibits [output port operation].)

- (2) Press the [UP] key to specify an output port to be operated.
⇒ Every pressing the key shifts the code number in the order of the figures to the right.
- (3) Press the [DOWN] key to operate ON/OFF the selected port.
⇒ Every pressing the key alters the port state (ON→OFF→ON→).
- (4) To terminate the output port operation, press the [SET] key at least 0.1 second.
⇒ Flashing of 1st digit stops and [output port operation] is inhibited.

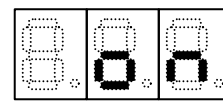
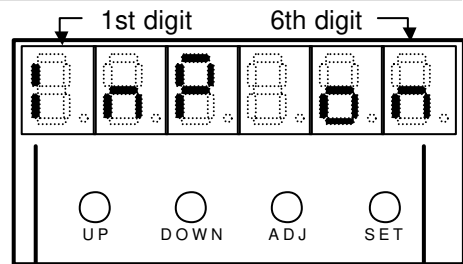

ON

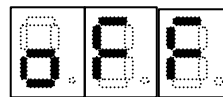

OFF

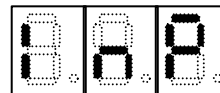

In-position
IN-POS: CN2-33

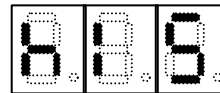

Attained speed
HI-SPD: CN2-33

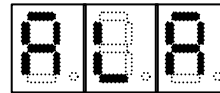

Alarm
ALARM: CN2-34

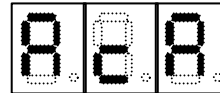

Alarm-A
ALARM: CN2-38

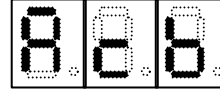

Alarm-B
ALARM: CN2-39

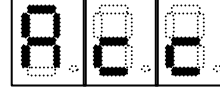

Alarm-C
ALARM: CN2-40

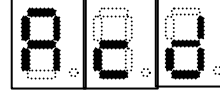

Alarm-D
ALARM: CN2-41

[Test mode]



I/O port operation (position / speed mode)

• Function

The display indicates input/output signal states of [CN2] connector pins as follows:

Output signals: Fourth digit
 Input signals: Sixth digit

An element of the two 7-segment indicators light up when the related signal is input or output.

This function is limited only to logic signals; it is not available for the encoder signals.

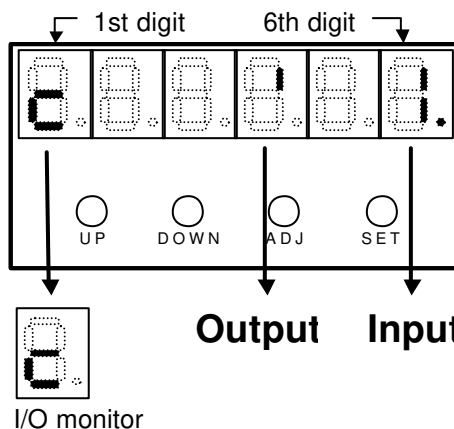

• Details of display

1st digit: [c:I/O monitor]
 2nd digit: No indication
 3rd to 4th digit: Indicates output signal states
 5th digit: No indication
 6th digit: Indicates input signal states

for outputs

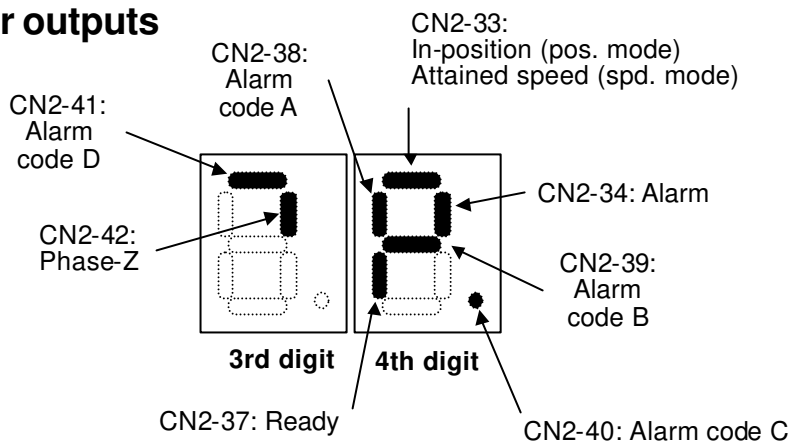

for inputs

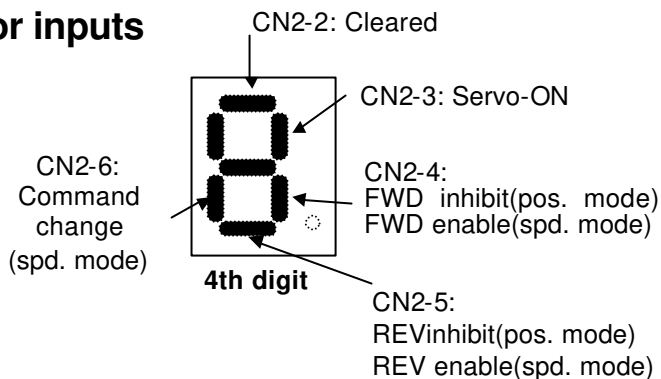

[Test mode]

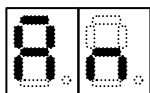

Analog monitor manual output (speed mode)

• Function

It is possible to output voltage signals manually through the monitor ports in the speed mode. Two analog ports are provided for monitoring.

Speed monitor: SPD-MON (CN2-23pin)

Current monitor: CUR-MON (CN2-24pin)

• Details of display

1st and 2nd digit: [An: analog monitor manual output]

3rd to 6th digit: indicates current output voltage.

• Operations

- (1) To transfer to in the [analog monitor manual output] mode, press the [ADJ] key at least 0.1 second.
 ⇒ 1st digit [A] flashes now you can output voltage signals.
 (Pressing the [ADJ] key at least 0.1 second again inhibits the [analog monitor manual output].)
- (2) To output voltage from [speed monitor: SPD-MON (CN2-23pin)], press the [UP] key.
 ⇒ While pressing, the pin continues to output varying voltage signal.
- (3) To output voltage from [current monitor: CUR-MON (CN2-24pin)], press the [DOWN] key.
 ⇒ While pressing, the pin continues to output varying voltage signal.
- (4) To terminate [analog monitor manual output] operation, press the [SET] key at least 0.1 second.
 ⇒ Flashing of 1st digit stops and [analog monitor manual output] operation is inhibited.

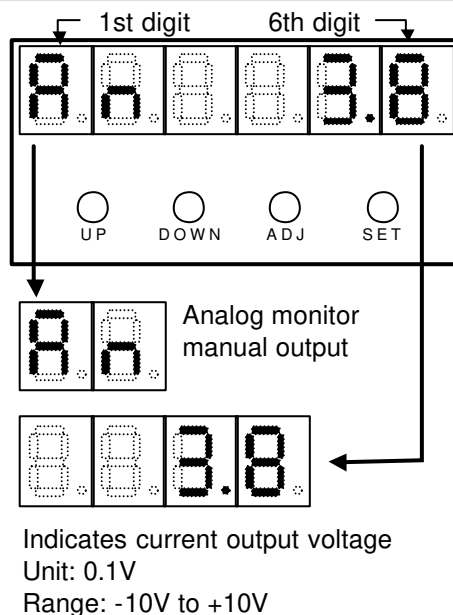

[Test mode]

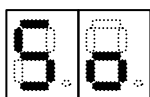

Speed command auto-offset (speed mode)

• Function

In the speed mode, the motor will rotate slightly in spite of a [0V] speed command voltage. This problem will happen when the speed command voltage has an offset of a few milli-volt. This function automatically removes the slight rotation compensating the command voltage offset.

• Details of display

1st and 2nd digit: [So: speed command auto-offset]

3rd to 6th digit: Indicates current [Speed command offset]

Note: Though the minimum offset value is possible to set [-9999], the indication for the minimum is [-999] (lower three digits only). To confirm the offset value, indicate the [tune mode] → [9: speed command offset].

• Operations

- To function the [speed command auto-offset], press the [ADJ] key at least 0.1 second.
⇒ 1st digit [S] flashes. It will now function.
(Pressing [ADJ] key at least 0.1 second again inhibits the operation.)
- To function [speed command auto-offset], press the [SET] key.
⇒ Automatic offset starts. When the offset completes, flashing [S] of the first digit stops.

• Related functions

[Speed command offset]: [tune mode] → [9: speed command offset]

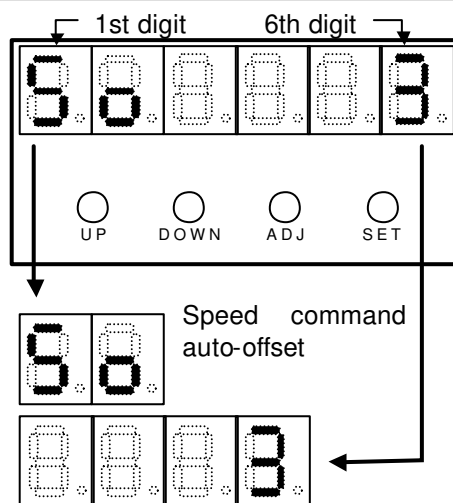

Indicates current [Speed command offset] value
Range: -999 to 9999

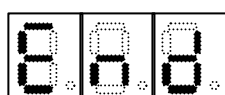

End of test mode

• Function

This terminates the [test mode] and returns to the [monitor mode]. Indicating [End] and pressing the [SET] key returns you to the [monitor mode].

• Details of display

1st to 3rd digit: No indication

4th to 6th digit: Indicates the [End]

• Operations

To terminate the [test mode] and to return to the [monitor mode], press the [SET] with [End] indicated.

⇒ The test mode returns to the [monitor mode].

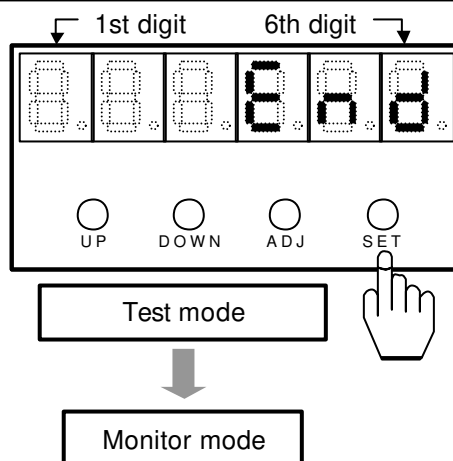

6-8 Defaults of parameters

The following table shows the defaults of the parameters:

<< for incremental encoder system >>

Mode	Code	Parameter	Actuator											
			FHA-17C			FHA-25C			FHA-32C			FHA-40C		
			1/50	1/100	1/160	1/50	1/100	1/160	1/50	1/100	1/160	1/50	1/100	1/160
Tune mode	0	Speed loop gain	25	25	25	50	50	50	80	80	80	120	120	120
	1	S-loop integral compensation	40	40	40	40	40	50	40	40	40	40	40	40
	2	Position loop gain	40	40	40	40	40	40	40	40	40	40	40	40
	3	Feed-forward gain	0	0	0	0	0	0	0	0	0	0	0	0
	4	In-position range	10	10	10	10	10	10	10	10	10	10	10	10
	5	Attained speed	2000	2000	2000	2000	2000	2000	2000	2000	2000	2000	2000	2000
	6	Internal speed command	0	0	0	0	0	0	0	0	0	0	0	0
	7	Acceleration time constant	0	0	0	0	0	0	0	0	0	0	0	0
	8	Deceleration time constant	0	0	0	0	0	0	0	0	0	0	0	0
	9	Speed command offset	-	-	-	-	-	-	-	-	-	-	-	-
Parameter mode	0	Control mode	0	0	0	0	0	0	0	0	0	0	0	0
	1	Command configuration	0	0	0	0	0	0	0	0	0	0	0	0
	2	Multiplication of 2-phase pulse	1	1	1	1	1	1	1	1	1	1	1	1
	3	Electronic gear - denominator	1	1	1	1	1	1	1	1	1	1	1	1
	4	Electronic gear - numerator	1	1	1	1	1	1	1	1	1	1	1	1
	5	Error count cleared by S-ON	0	0	0	0	0	0	0	0	0	0	0	0
	6	Position error allowance	100	100	100	100	100	100	100	100	100	100	100	100
	7	Zero clamp	0	0	0	0	0	0	0	0	0	0	0	0
	8	Rotary direction	0	0	0	0	0	0	0	0	0	0	0	0
	9	Speed conversion factor	4800	4800	4800	4500	4500	4500	4000	4000	4000	3500	3500	3500
	A	Speed limit	4900	4900	5000	4600	4600	4600	4100	4100	4100	3600	3600	3600
	b	Torque limit	100	100	100	100	100	100	100	100	100	100	100	100
	c	Alarm logic	0	0	0	0	0	0	0	0	0	0	0	0

Note: the values are available for 200V systems.

<< for absolute encoder system >>

Mode	Code	Parameter	Actuator											
			FHA-17C			FHA-25C			FHA-32C			FHA-40C		
			1/50	1/100	1/160	1/50	1/100	1/160	1/50	1/100	1/160	1/50	1/100	1/160
Tune mode	0	Speed loop gain	25	25	25	50	50	50	80	80	80	120	120	120
	1	S-loop integral compensation	40	40	40	50	50	50	40	40	40	70	70	70
	2	Position loop gain	40	40	40	40	40	40	40	40	40	40	40	40
	3	Feed-forward gain	0	0	0	0	0	0	0	0	0	0	0	0
	4	In-position range	10	10	10	10	10	10	10	10	10	10	10	10
	5	Attained speed	2000	2000	2000	2000	2000	2000	2000	2000	2000	2000	2000	2000
	6	Internal speed command	0	0	0	0	0	0	0	0	0	0	0	0
	7	Acceleration time constant	0	0	0	0	0	0	0	0	0	0	0	0
	8	Deceleration time constant	0	0	0	0	0	0	0	0	0	0	0	0
	9	Speed command offset	-	-	-	-	-	-	-	-	-	-	-	-
Parameter mode	0	Control mode	0	0	0	0	0	0	0	0	0	0	0	0
	1	Command configuration	0	0	0	0	0	0	0	0	0	0	0	0
	2	Multiplication of 2-phase pulse	1	1	1	1	1	1	1	1	1	1	1	1
	3	Electronic gear - denominator	1	1	1	1	1	1	1	1	1	1	1	1
	4	Electronic gear - numerator	1	1	1	1	1	1	1	1	1	1	1	1
	5	Error count cleared by S-ON	0	0	0	0	0	0	0	0	0	0	0	0
	6	Position error allowance	100	100	100	100	100	100	100	100	100	100	100	100
	7	Zero clamp	0	0	0	0	0	0	0	0	0	0	0	0
	8	Rotary direction	0	0	0	0	0	0	0	0	0	0	0	0
	9	Speed conversion factor	4800	4800	4800	4500	4500	4500	4000	4000	4000	3500	3500	3500
	A	Speed limit	5000	5000	5000	4600	4600	4600	4100	4100	4100	3600	3600	3600
b	Torque limit	100	100	100	100	100	100	100	100	100	100	100	100	
c	Alarm logic	0	0	0	0	0	0	0	0	0	0	0	0	
d	-	-	-	-	-	-	-	-	-	-	-	-	-	
E	-	-	-	-	-	-	-	-	-	-	-	-	-	
F	ABS multi-turn data clear	2500	2500	2500	2500	2500	2500	2500	2500	2500	2500	2500	2500	

Note: the values are available for 200V systems.

Chapter 7 Troubleshooting

7-1 Alarms and diagnostic tips

The HA-655 drivers provide various functions to protect actuators and drivers against abnormal operating conditions. When these functions detect faults, the actuator stops (the motor enters a free rotation state.), a two-digit alarm code is indicated on the display panel, and a corresponding alarm signal is transmitted to the hosts.

alarm code	Alarm description	4-bit code	ALM -D	ALM -C	ALM -B	ALM -A	Releasing
10	Over speed	1011	ON	OFF	ON	ON	Impossible
20	Over load	0001	OFF	OFF	OFF	ON	Possible
21	Overheat	1000	ON	OFF	OFF	OFF	Impossible
30	Over current	1001	ON	OFF	OFF	ON	Impossible
41	Abnormal regeneration	1010	ON	OFF	ON	OFF	Impossible
50	Encoder failure	1101	ON	ON	OFF	ON	Impossible
51	Abnormal encoder signal	1101	ON	ON	OFF	ON	Impossible
52	UVW failure	1101	ON	ON	OFF	ON	Impossible
53	*ABS system failure	1101	ON	ON	OFF	ON	Impossible
54	*ABS MTD over flow	1101	ON	ON	OFF	ON	Impossible
55	*ABS multi-turn data error	1101	ON	ON	OFF	ON	Impossible
56	*ABS low battery voltage	1101	ON	ON	OFF	ON	Impossible
57	*ABS send data rule error	1101	ON	ON	OFF	ON	Impossible
60	Error counter overflow	0010	OFF	OFF	ON	OFF	Possible
70	Memory failure (RAM)	0101	OFF	ON	OFF	ON	Impossible
71	Memory failure (EEPROM)	0101	OFF	ON	OFF	ON	Impossible
76	CPU failure	0100	OFF	ON	OFF	OFF	Impossible

Note: the alarm codes 53 through 57 are valid for absolute encoders only.

Causes and remedies of alarms are described as follows:

Note: If after troubleshooting the alarms cannot be cleared, shut the control power off and turn the driver on again.



1. After powering the driver for troubleshooting, do not make wiring changes. Shut off the electric power source before any wiring changes are made.
2. Clean around the device. Make sure there are no wire chips or tools inside the equipment.
3. When two or more persons are working on the equipment, make sure all are alerted and safe before power is restored to the machine.

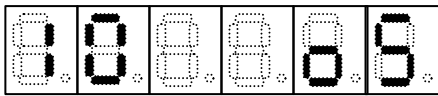

Over speed (release: impossible)

- **Description**

The alarm will occur if the motor exceeds its maximum speed or if it rotates abnormally. To release the alarm, shut off the control power once and turn it on again.

- **Diagnostic tips**

(1) Motor exceeds maximum speed when control power is turned on:

- ◆ Cause 1: The control circuit of the HA-655 driver may have failed.
 ⇒ Remedy: Contact harmonic drive systems.
 (Replace The HA-655 driver)

(2) Actuator ran at a high speed due to a rotation command:

- ◆ Cause 1: (position mode)[command pulse frequency] is too high.
 ⇒ Remedy: Lower the [command pulse frequency] of the host.
 The frequency should be less than: Actuator's rated speed (r/min) × 60
 You can monitor the frequency by
 [monitor mode] → [A: command pulse frequency]
- ◆ Cause 2: (speed mode)[speed command voltage] is too high.
 ⇒ Remedy: Lower the [speed command voltage] of the host.
 You can monitor the voltage by
 [monitor mode] → [2: speed command voltage]
- ◆ Cause 3: [speed conversion factor] is too high.
 ⇒ Remedy: Lower the factor by [parameter mode] → [9: speed conversion factor].
- ◆ Cause 4: [speed conversion factor] is wrong.
 ⇒ Remedy: Set the proper factor by [parameter mode] → [9: speed conversion factor].
- ◆ Cause 5: Excessive overshoot caused by poor gain adjustment
 ⇒ Remedy: Adjust gains in [tune mode] → [0: speed loop gain],[1: speed loop integral compensation] and [2: position loop gain] proportional to the load.
- ◆ Cause 6: Improper connection of motor and encoder cables
 ⇒ Remedy: Connect cables correctly referring to [chapter 4: Installing the HA-655 driver] of this manual.

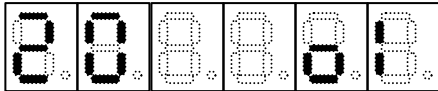

Over load (release: possible)

• Description

The driver always monitors the motor current and if the current exceeds the curve in the figure below, then an overload alarm occurs.

For example:

- (1) The alarm occurs if the current is 1.2 times of nominal for a long period of time.
- (2) The alarm occurs if the current of three times of the nominal current flows for 20 seconds.

It is possible to release the alarm by inputting the ON signal to [CN2-2 clear: CLEAR], if the overload condition has been corrected.

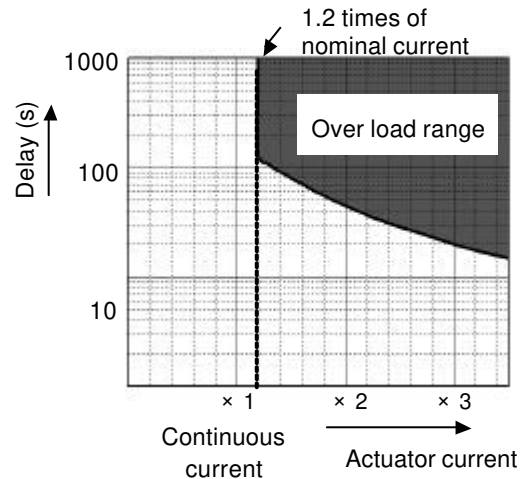

• Diagnostic tips

(1) Alarm occurs when control power is turned on:

- ◆ Cause 1: The control circuit of the HA-655 driver may have failed.
⇒ Remedy: Contact harmonic drive systems.(Replace the HA-655 driver)

(2) Alarm occurs when servo power is turned on:

- ◆ Cause 1: The encoder connector (CN1) may not be connected.
⇒ Remedy: Verify connection of encoder connector (CN1).

(3) The alarm occurs while running (it is possible to restart after shutting off control power):

- ◆ Cause 1: Running at over load state
⇒ Remedy: Review the actuator's actual load profile to lower the duty.

(4) Alarm occurs after hunting motion:

- ◆ Cause 1: Hunting motion is caused by poor gain adjustment
⇒ Remedy: Adjust gains in [tune mode] → [0: speed loop gain],[1: speed loop integral compensation] and [2: position loop gain] proportional to the load.

(5) Alarm does not occur when driving the actuator only (no load), but alarm occurs with load:

- ◆ Cause 1: Wrong connection of motor and encoder cables
⇒ Remedy: Connect cables correctly referring to [chapter 4 : Installing the HA-655 driver] in this manual.

(6) Alarm occurs when driving the actuator only (no load):

- ◆ Cause 1: Wrong connection of motor and encoder cables
⇒ Remedy: Connect cables correctly referring to [chapter 4: Installing the HA-655 driver] in this manual.

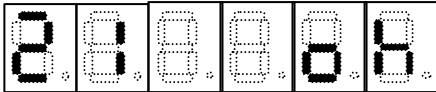

Overheat (release: impossible)

- **Description**

The alarm occurs when the thermal switch of an IPM element in The HA-655 driver is activated. To release the alarm after troubleshooting, shut off the control power once and turn it on again.

- **Diagnostic tips**

(1) Alarm occurs when control power is turned on:

- ◆ Cause 1: The control circuit of the HA-655 driver may have failed.

⇒ Remedy: Contact Harmonic Drive Systems.
(Replace the HA-655 driver)

(2) The alarm occurs during running (restarting is possible after 4 to 5 minutes from the alarm.):

- ◆ Cause 1: Running at over load state

⇒ Remedy: Review the actuator's actual load profile to lower the duty.

- ◆ Cause 2: The temperature around the HA-655 driver exceeds 50°C.

⇒ Remedy: Review the location of the HA-655 driver and its cooling system.

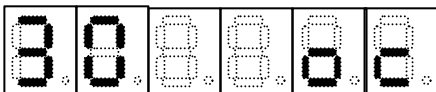

Over current (release: impossible)

- **Description**

This alarm occurs when the servo control element of the driver detects over current. To release the alarm after troubleshooting, shut off the control power and turn it on again.

- **Diagnostic tips**

(1) Alarm occurs when control power is turned on:

- ◆ Cause 1: The control circuit of the HA-655 driver may have failed.

⇒ Remedy: Contact Harmonic Drive Systems.
(Replace the HA-655 driver)

(2) Alarm occurs by input signal of [CN2-3: S-ON (servo-ON)] is activated:

- ◆ Cause 1: The control or main circuit of the HA-655 driver may have failed.

⇒ Remedy: Contact Harmonic Drive Systems.
(Replace the HA-655 driver)

(3) Alarm occurs by input signal of [CN2-3: S-ON (servo-ON)] is activated, but doesn't occur when off the motor cable (U,V,W) is disconnected from the driver:

- ◆ Cause 1: Short connection in the motor cable

⇒ Remedy: Verify the connection of the motor cable and correct it as needed.

- ◆ Cause 2: Short connection in the motor winding

⇒ Remedy: Contact Harmonic Drive Systems.
(Replace actuator)

(4) Alarm occurs during acceleration or deceleration:

- ◆ Cause 1: Excessive load inertia and the accelerating or decelerating time is too short.
 - ⇒ Remedy 1: Reduce the load inertia.
 - ⇒ Remedy 2: Set longer times for [tune mode] → [7: acceleration time constant] and [8: deceleration time constant].
- ◆ Cause 2: Gain is set too high or too low
 - ⇒ Remedy 1: Adjust gains [parameter mode] → [0: speed loop gain], [1: speed loop integral compensation] and [2: position loop gain].

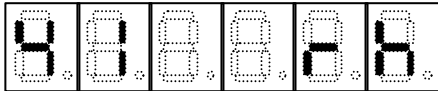
**Abnormal regeneration** (release: imp.)

- **Description**

This alarm occurs when the thermal switch of the regeneration resistor in the HA-655 driver is activated at 100°C. To release the alarm after troubleshooting, shut off the control power and turn it on again.

- **Diagnostic tips**

(1) Alarm occurs during deceleration

- ◆ Cause 1: The capacity of the regeneration resistor is too small.
 - ⇒ Remedy: Install an external resistor to make the capacity larger.
- ◆ Cause 2: The regeneration circuit of the HA-655 driver may have failed.
 - ⇒ Remedy: Contact Harmonic Drive Systems. (Replace the HA-655 driver)

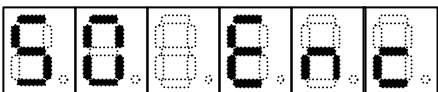
**Encoder failure** (release: impossible)

- **Description**

This alarm occurs when the encoder signal ceases. To release the alarm after troubleshooting, shut off the control power and turn it on again.

- **Diagnostic tips**

(1) Alarm occurs when the control power is turned on:

- ◆ Cause 1: The control circuit of the HA-655 driver may have failed.
 - ⇒ Remedy: Contact Harmonic Drive Systems. (Replace the HA-655 driver)
- ◆ Cause 2: The encoder connector (CN1) may not be connected or may be improperly wired.
 - ⇒ Remedy: Verify connection of encoder connector (CN1) and connect it firmly.
- ◆ Cause 3: The encoder circuit may have failed.
 - ⇒ Remedy: Contact Harmonic Drive Systems. (Replace actuator)

(2) Alarm occurs during running (recovers after cooling of the actuator)

- ◆ Cause 1: Encoder malfunctions when the actuator temperature rises.
 - ⇒ Remedy: Review the actuator operating load, duty cycle, and its cooling system.

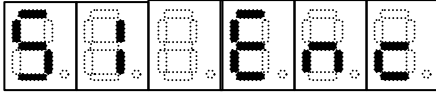

Abnormal encoder signal (release: imp.)

- **Description**

This alarm occurs when the driver fails to receive the two sequential encoder signals. To release the alarm after troubleshooting, shut off the control power and turn it on again.

- **Diagnostic tips**

(1) Alarm occurs when the control power is turned on:

- ◆ Cause 1: The control circuit of the HA-655 driver may have failed.
⇒ Remedy: Contact Harmonic Drive Systems. (Replace the HA-655 driver)
- ◆ Cause 2: The encoder connector (CN1) may not be connected or may be connected poorly.
⇒ Remedy: Verify connection of encoder connector (CN1) and connect it firmly.
- ◆ Cause 3: The encoder circuit may have failed.
⇒ Remedy: Contact Harmonic Drive Systems. (Replace actuator)

(2) Temporally alarm occurs during running:

- ◆ Cause 1: Malfunction may be caused by surrounding electrical noise.
⇒ Remedy: Install the driver correctly referring [Chapter 4- 4: Noise Suppression] in this manual.



UVW failure (release: impossible)

- **Description**

The alarm occurs when the encoder UVW signals are abnormal. To release the alarm after troubleshooting, shut off the control power and turn it on again.

- **Diagnostic tips**

(1) Alarm occurs when the control power is turned on:

- ◆ Cause 1: The control circuit of the HA-655 driver may have failed.
⇒ Remedy: Contact Harmonic Drive Systems. (Replace the HA-655 driver)
- ◆ Cause 2: The encoder connector (CN1) may not be connected or may be connected poorly.
⇒ Remedy: Verify connection of encoder connector (CN1) and connect it firmly.
- ◆ Cause 3: The encoder circuit may have failed.
⇒ Remedy: Contact Harmonic Drive Systems. (Replace actuator)

(2) Alarm occurs temporarily while running:

- ◆ Cause 1: Malfunction may be caused by surrounding electrical noise.
⇒ Remedy: Install the driver correctly referring [Chapter 4-4: Noise Suppression] in this manual.



ABS system failure (release: possible)

- **Description**

For the absolute encoder, the alarm occurs when all power supplies (power supply, built-in condenser, and battery) for the encoder are failure. For example, it occurs at the first power supply after purchasing, and at power supply after disconnecting the cable between the driver and the encoder for a long duration.

- **Diagnostic tips**

(1) Alarm occurs when the control power is turned on:

- ◆ Cause 1: The first power supply after purchasing
⇒ Remedy: Input the multi-turn data clear signal at least 4 seconds, and shut off the control power once and turn it on again.
- ◆ Cause 2: The power supply after disconnecting the cable between the driver and the encoder for a long duration :
⇒ Remedy: Input the multi-turn data clear signal at least 4 seconds, and shut off the control power once and turn it on again.
- ◆ Cause 3: The control circuit of the HA-655 driver may have failed.
⇒ Remedy: Contact Harmonic Drive Systems. (Replace the HA-655 driver)
- ◆ Cause 4: The encoder connector (CN1) may not be connected or may be connected poorly.
⇒ Remedy: Verify connection of encoder connector (CN1) and connect it firmly.
- ◆ Cause 5: The encoder circuit may have failed.
⇒ Remedy: Contact Harmonic Drive Systems. (Replace actuator)

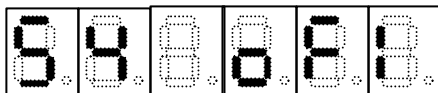

ABSMTD overflow (release: impossible)

- **Description**

For the absolute encoder, the alarm occurs when the count for multi-turn data (MTD) goes beyond the range of +4095 to - 4096 turns (motor axis). To recover the alarm, input the multi-turn data clear signal at least 4 seconds, and shut off the control power once and turn it on again.

- **Diagnostic tips**

(1) Alarm occurs when the control power is turned on:

- ◆ Cause 1: The control circuit of the HA-655 driver may have failed.
⇒ Remedy: Contact Harmonic Drive Systems. (Replace the HA-655 driver)
- ◆ Cause 2: The encoder connector (CN1) may not be connected or may be connected poorly.
⇒ Remedy: Verify connection of encoder connector (CN1) and connect it firmly.
- ◆ Cause 3: The encoder circuit may have failed.
⇒ Remedy: Contact Harmonic Drive Systems. (Replace actuator)

(2) Alarm occurs during running:

- ◆ Cause 1: The alarm when the count for multi-turn data (MTD) goes beyond the range of +4095 to -4096 turns (motor axis).
 - ⇒ Remedy: input the multi-turn data clear signal at least 4 seconds, and shut off the control power once and turn it on again.

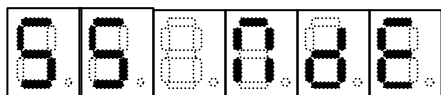
**ABS multi-turn data error** (release: imp.)

- **Description**

For the absolute encoder, during an energy-saving mode, where no power by power supply but the encoder circuit is active only by the power of a built-in condenser and a built-in battery, the alarm occurs when the encoder rotates too fast at the acceleration rate and speed exceeding the recording ability of the multi-turn counter on the mode. To recover the alarm, input the multi-turn data clear signal at least 4 seconds, and shut off the control power once and turn it on again.

- **Diagnostic tips**

(1) Alarm occurs when the control power is turned on:

- ◆ Cause 1: The encoder rotates during no control power supply.
 - ⇒ Remedy: Input the multi-turn data clear signal at least 4 seconds, and shut off the control power once and turn it on again.
- ◆ Cause 2: The control circuit of the HA-655 driver may have failed.
 - ⇒ Remedy: Contact Harmonic Drive Systems. (Replace the HA-655 driver)
- ◆ Cause 3: The encoder connector (CN1) may not be connected or may be connected poorly.
 - ⇒ Remedy: Verify connection of encoder connector (CN1) and connect it firmly.
- ◆ Cause 4: The encoder circuit may have failed.
 - ⇒ Remedy: Contact Harmonic Drive Systems. (Replace actuator)

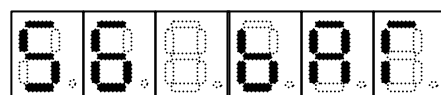
**ABS low battery voltage** (release: imp.)

- **Description**

For the absolute encoder, when voltage of the built-in battery is low. To recover the alarm, change the battery for a new one, and shut off the control power once and turn it on again.

- **Diagnostic tips**

(2) Alarm occurs when the control power is turned on:

- ◆ Cause 1: The voltage of the built-in battery is less than 2.80V.
 - ⇒ Remedy: Change the battery for a new one.
- ◆ Cause 2: The control circuit of the HA-655 driver may have failed.
 - ⇒ Remedy: Contact Harmonic Drive Systems. (Replace the HA-655 driver)
- ◆ Cause 3: The encoder connector (CN1) may not be connected or may be connected poorly.
 - ⇒ Remedy: Verify connection of encoder connector (CN1) and connect it firmly.

- ◆ Cause 4: The encoder circuit may have failed.
⇒ Remedy: Contact Harmonic Drive Systems. (Replace actuator)

(2) Alarm occurs during running:

- ◆ Cause 1: The voltage of the built-in battery is less than 2.80V.
⇒ Remedy: Change the battery for a new one.

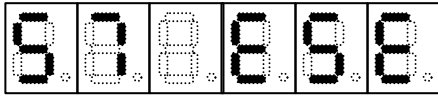

ABS send data rule error (release: imp.)

● **Description**

The absolute encoder rotates more than 127 resolvable pulses by external torque during transmitting absolute data. To recover the alarm, shut off the control power once and turn it on again.

● **Diagnostic tips**

(2) Alarm occurs when the control power is turned on:

- ◆ Cause 1: The absolute encoder rotates more than 127 resolvable pulses by external torque during transmitting absolute data.
⇒ Remedy: Shut off the control power once and turn it on again.
- ◆ Cause 2: The control circuit of the HA-655 driver may have failed.
⇒ Remedy: Contact Harmonic Drive Systems. (Replace the HA-655 driver)
- ◆ Cause 3: The encoder connector (CN1) may not be connected or may be connected poorly.
⇒ Remedy: Verify connection of encoder connector (CN1) and connect it firmly.
- ◆ Cause 4: The encoder circuit may have failed.
⇒ Remedy: Contact Harmonic Drive Systems. (Replace actuator)

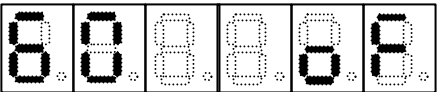

Error counter overflow (release: possible)

● **Description**

The alarm occurs when an error count exceeds the set value in [parameter mode] → [6: position error allowance]. It is possible to release the alarm by inputting ON signal to [CN2-2 clear: CLEAR]. The error count is reset simultaneously.

● **Diagnostic tips**

(1) Alarm occurs when the control power is turned on:

- ◆ Cause 1: The control circuit of the HA-655 driver may have failed.
⇒ Remedy: Contact Harmonic Drive Systems. (Replace the HA-655 driver)

(2) Alarm occurs during acceleration or deceleration

- ◆ Cause 1: Gain is too low
⇒ Remedy: Adjust gains [parameter mode] → [0: speed loop gain], [1: speed loop integral compensation] and [2: position loop gain].

- ◆ Cause 2: Parameters of the [electronic gear] are wrong.
 - ⇒ Remedy: Set the correct parameters by [parameter mode] → [3: electronic gear-denominator][4: electronic gear-numerator].
- ◆ Cause 3: The [command pulse frequency] is too high
 - ⇒ Remedy: Lower the [command pulse frequency] of the host.
 - The frequency should be less than: Actuator's rated speed (r/min) × 60
 - You can monitor the frequency by [monitor mode] → [A: command pulse frequency]
- ◆ Cause 4: The load inertia is too large
 - ⇒ Remedy1: Reduce the load inertia.
 - ⇒ Remedy2: Modify the motion profile to accelerate and decelerate more slowly.

(3) Speed did not rise with the command, and then the alarm occurs.

- ◆ Cause 1: OFF state of input signal [CN2-4: FWD inhibit] or [CN2-5: REV inhibit].
 - ⇒ Remedy: Verify breakage of CN2 connector cable.
 - Make sure both signals above are turning ON by [test mode] → [b: I/O monitor].

(4) Actuator did not rotate.

- ◆ Cause 1: Incorrect motor cable connection or wrong phase order
 - ⇒ Remedy1: Correct the connection between the motor cable and the connector.
 - ⇒ Remedy2: Connect the motor cable and the connector in correct phase order referring to [Chapter 4– 7: Connection Servomotor Cable and Regeneration Resistor] of this manual.
- ◆ Cause 2: Poor encoder connector (CN1) connection.
 - ⇒ Remedy: Plug the CN1 connector firmly.

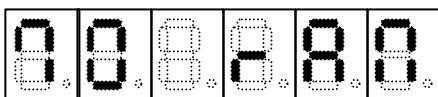

Memory failure (RAM) (release: impossible)

• Description

This alarm occurs when the driver's RAM memory fails. It is impossible to release the alarm.

• Diagnostic tips occurs

(1) Alarm occurs when control power is turned on:

- ◆ Cause 1: The control circuit of the HA-655 driver may have failed.
 - ⇒ Remedy: Contact Harmonic Drive Systems. (Replace the HA-655 driver)

(2) Alarm occurs while running

- ◆ Cause 1: Malfunction of a control element of the HA-655 driver
 - ⇒ Remedy: Contact Harmonic Drive Systems. (Replace the HA-655 driver)

Make sure that the installed location is suitable, referring [4-3 location and installation] of this manual.

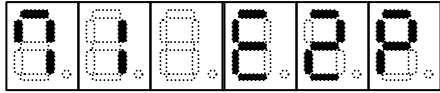

Memory failure (EEROM) (release: imp.)

- **Description**

This alarm occurs when the driver's EEROM memory fails. It is impossible to release the alarm.

- **Diagnostic tips occurs**

(1) Alarm occurs when the control power is turned on:

- ♦ Cause 1: The control circuit of the HA-655 driver may have failed.
⇒ Remedy: Contact Harmonic Drive Systems. (Replace the HA-655 driver)

(2) Alarm occurs during running

- ♦ Cause 1: Malfunction of a control element of the HA-655 driver
⇒ Remedy: Contact Harmonic Drive Systems. (Replace the HA-655 driver)

Make sure that the installed location is suitable, referring [4-3 location and installation] of this manual.

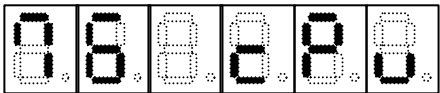

CPU failure (release: Impossible)

- **Description**

This alarm occurs when the driver's CPU fails. It is impossible to release the alarm.

- **Diagnostic tips**

(1) Alarm occurs when the control power is turned on:

- ♦ Cause 1: The control circuit of the HA-655 driver may have failed.
⇒ Remedy: Contact Harmonic Drive Systems. (Replace the HA-655 driver)

(2) Alarm occurs during running

- ♦ Cause 1: Malfunction may be caused by surrounding electrical noise.
⇒ Remedy: Install the driver correctly referring to [Chapter 4- 4 noise suppression].
- ♦ Cause 2: The control circuit of the HA-655 driver may have failed.
⇒ Remedy: Contact Harmonic Drive Systems. (Replace the HA-655 driver)

7-2 Troubleshooting for improper actuator motions

Troubleshooting procedures for problems other than alarms are described separately in the position mode and in the speed mode. They are also described for the following cases:

- ◆ No rotation
- ◆ Unstable rotation
- ◆ Poor positioning accuracy

Note: In the flowcharts, [Y] means [yes], and [N] means [no].

7-2-1 Improper motions in position mode

◆ No rotation

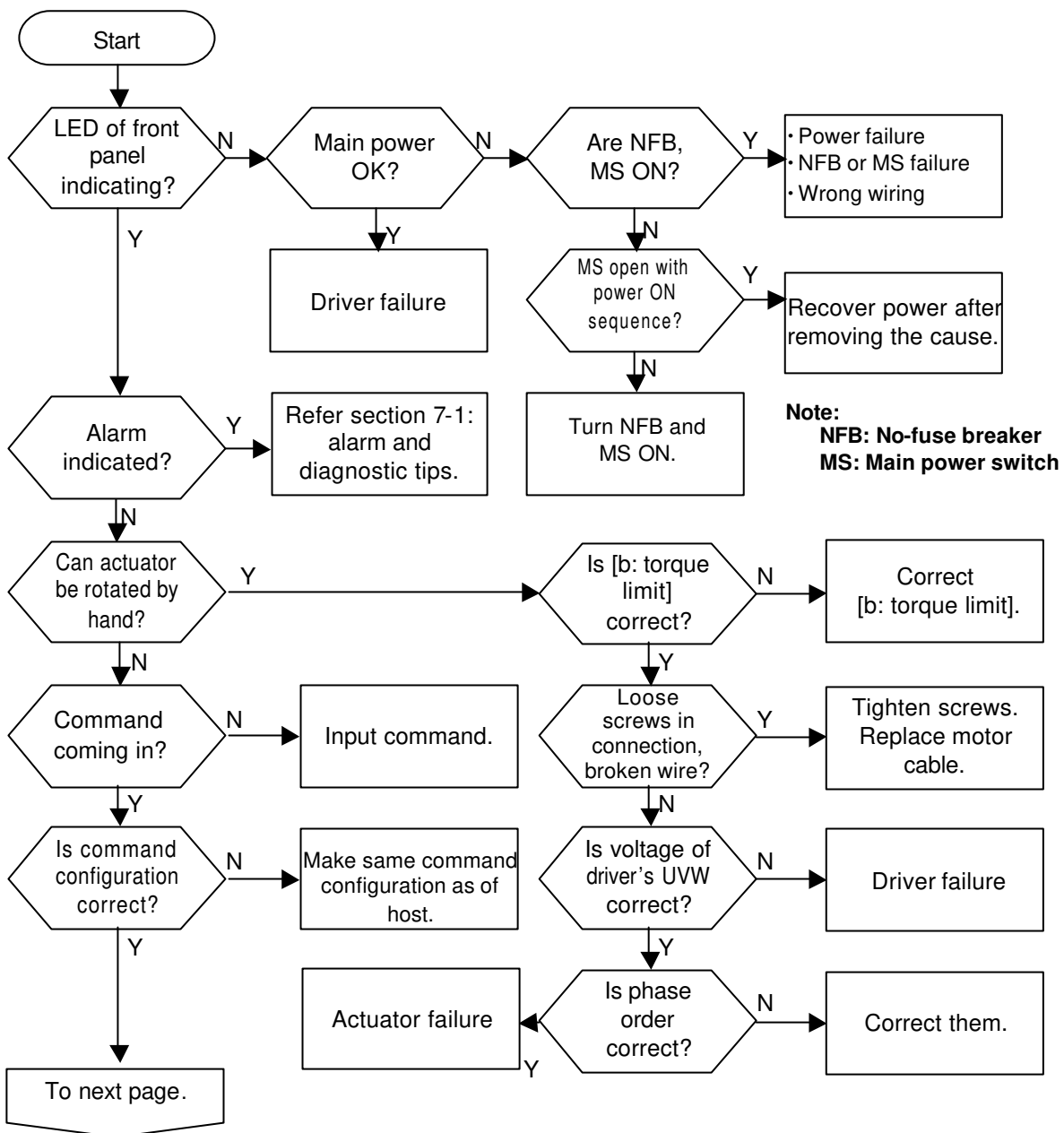

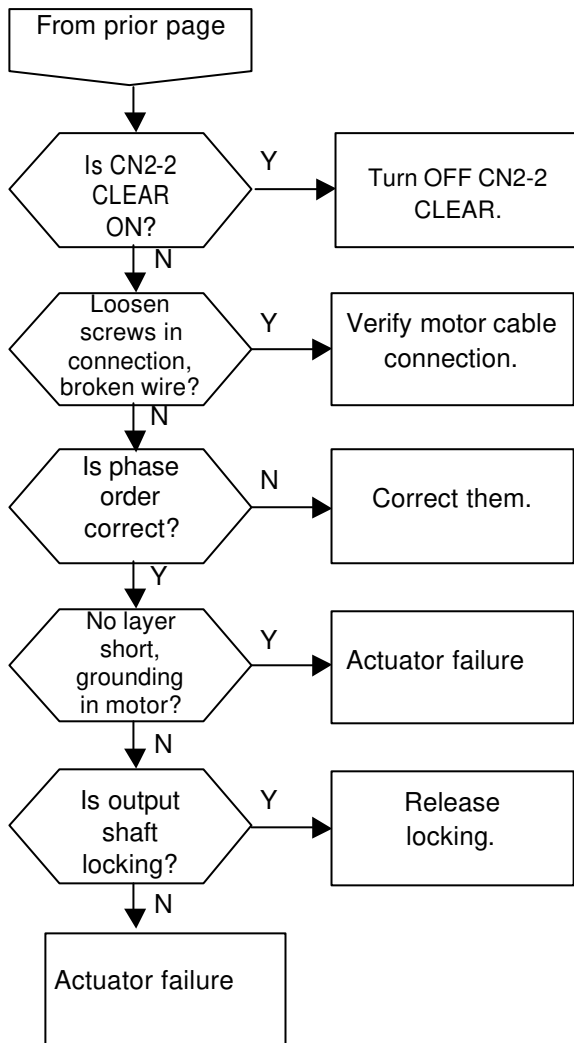

◆ **Unstable rotation**

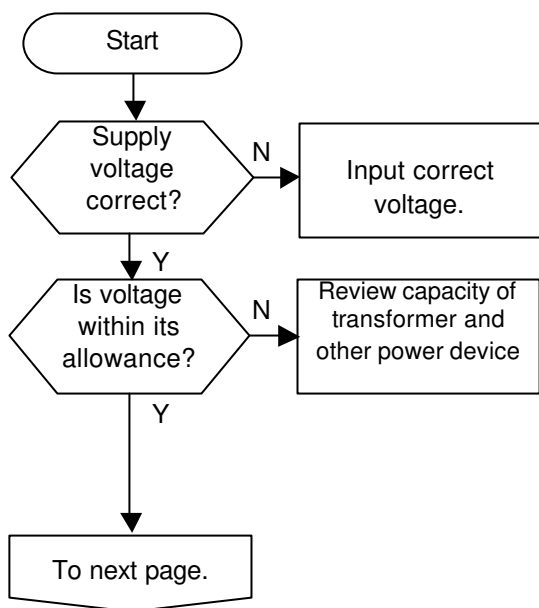

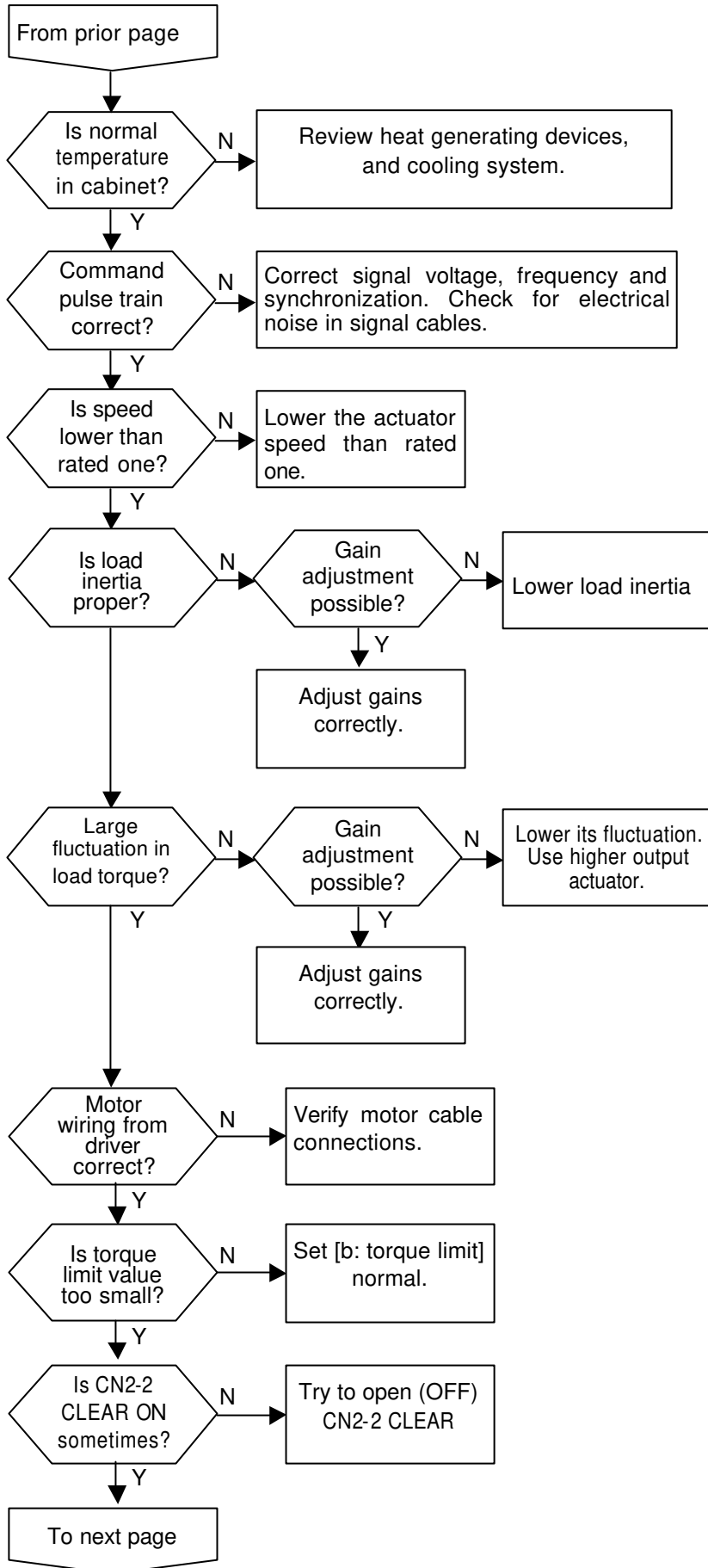

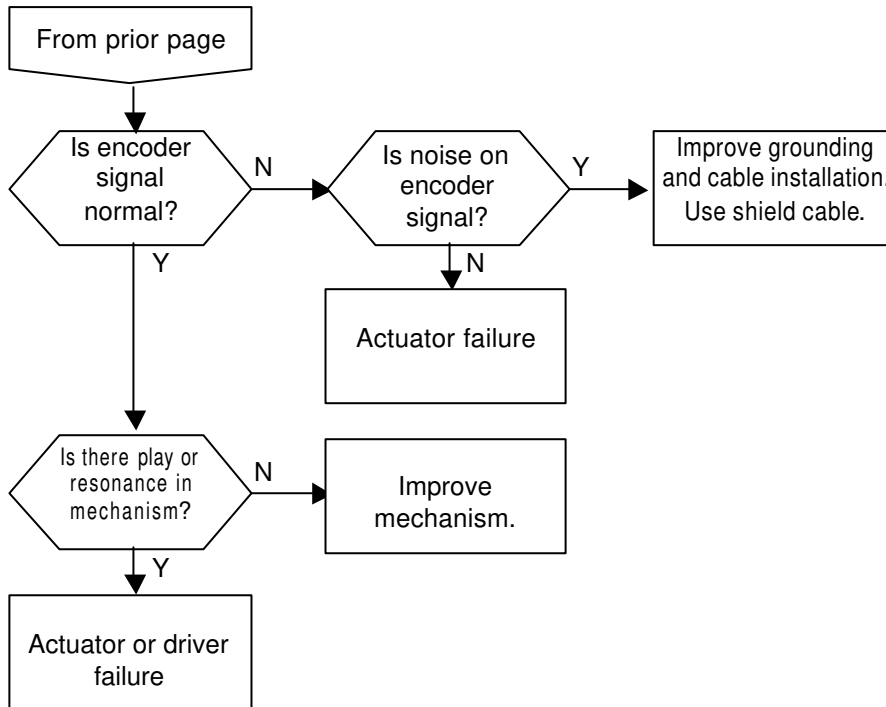

◆ **Poor positioning accuracy**

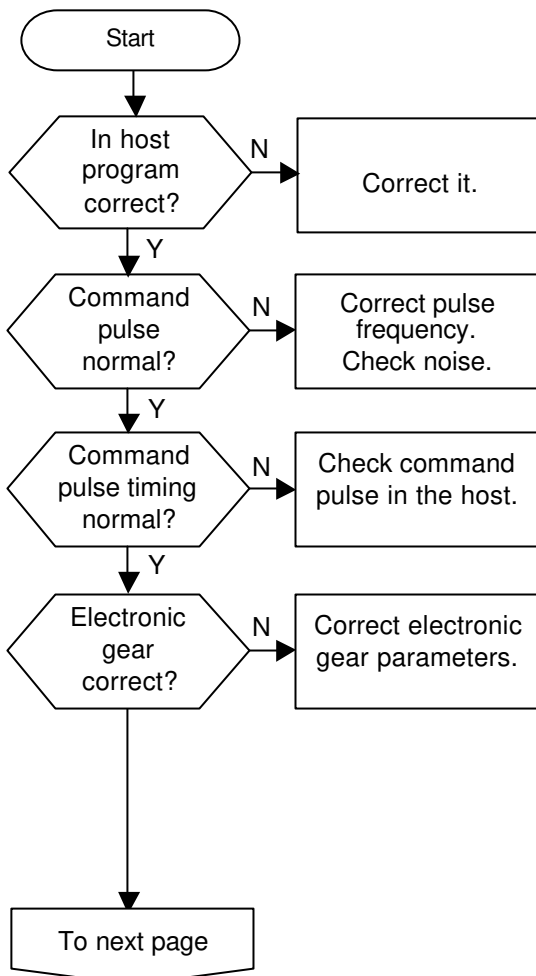

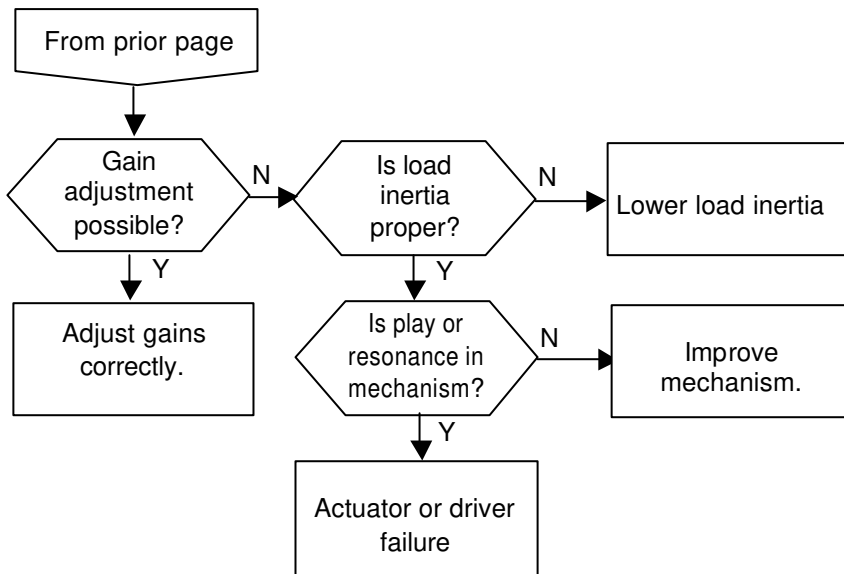

7-2-2 Improper motions in speed mode

◆ No rotation

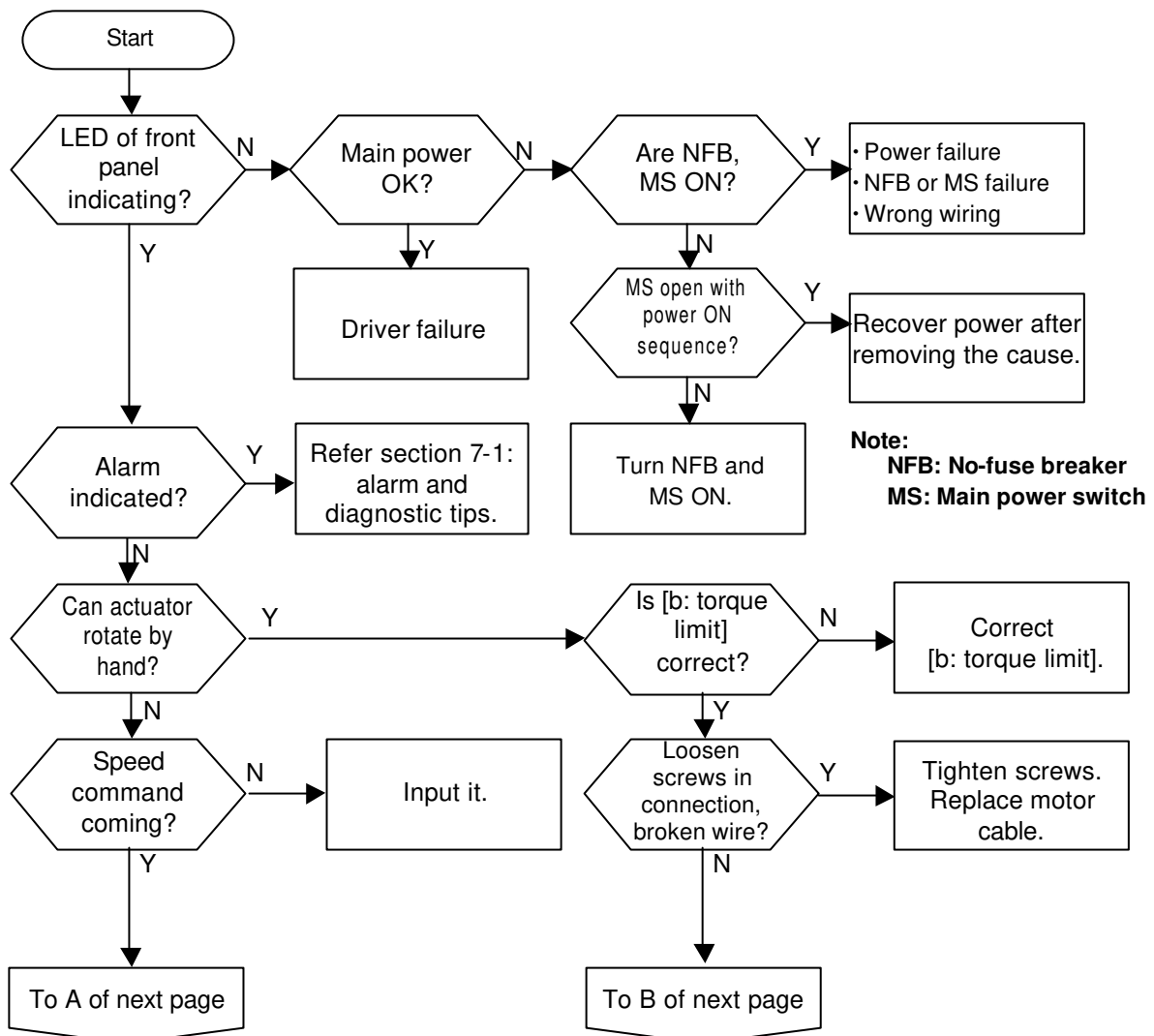

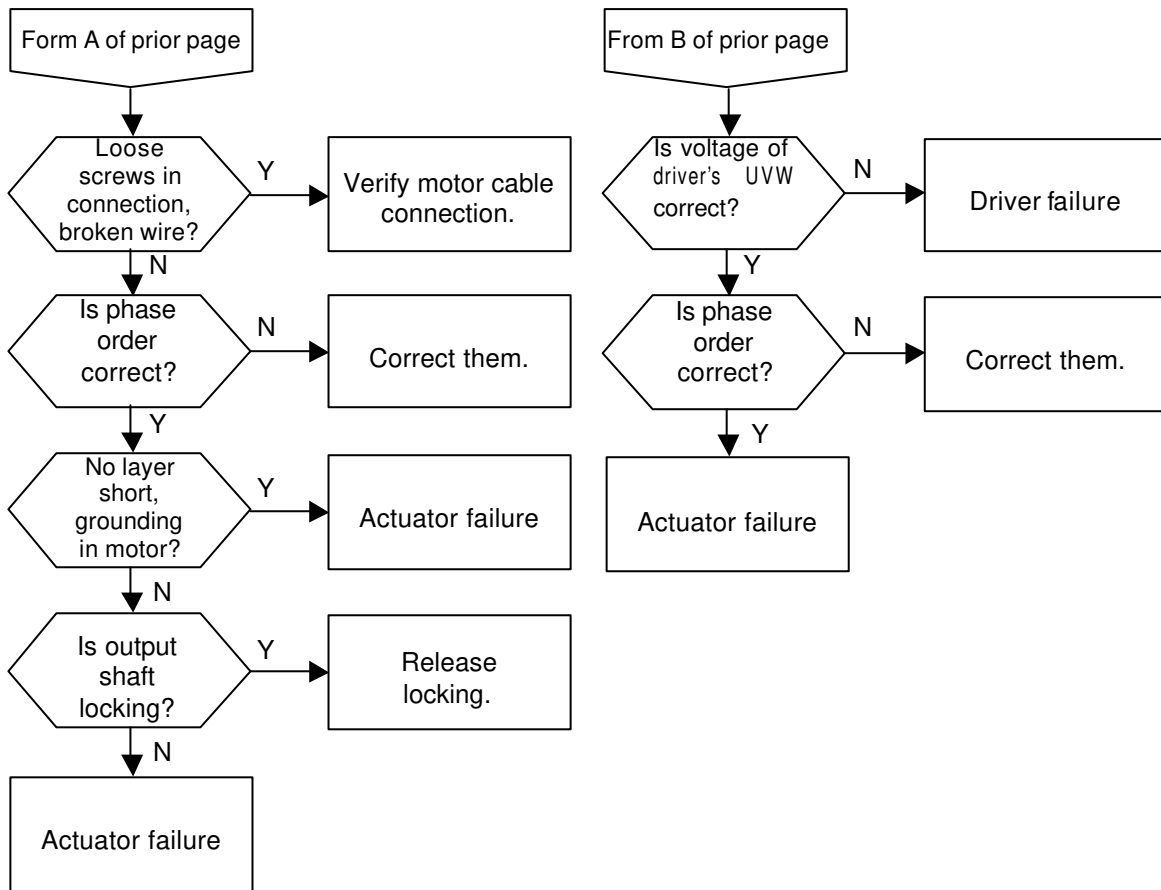

◆ **Unstable rotation**

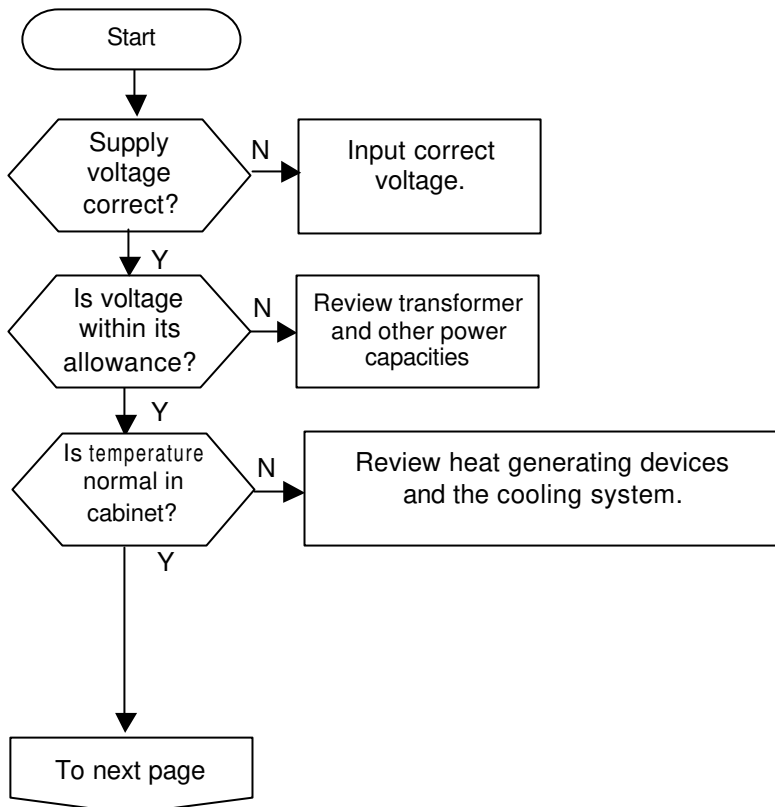

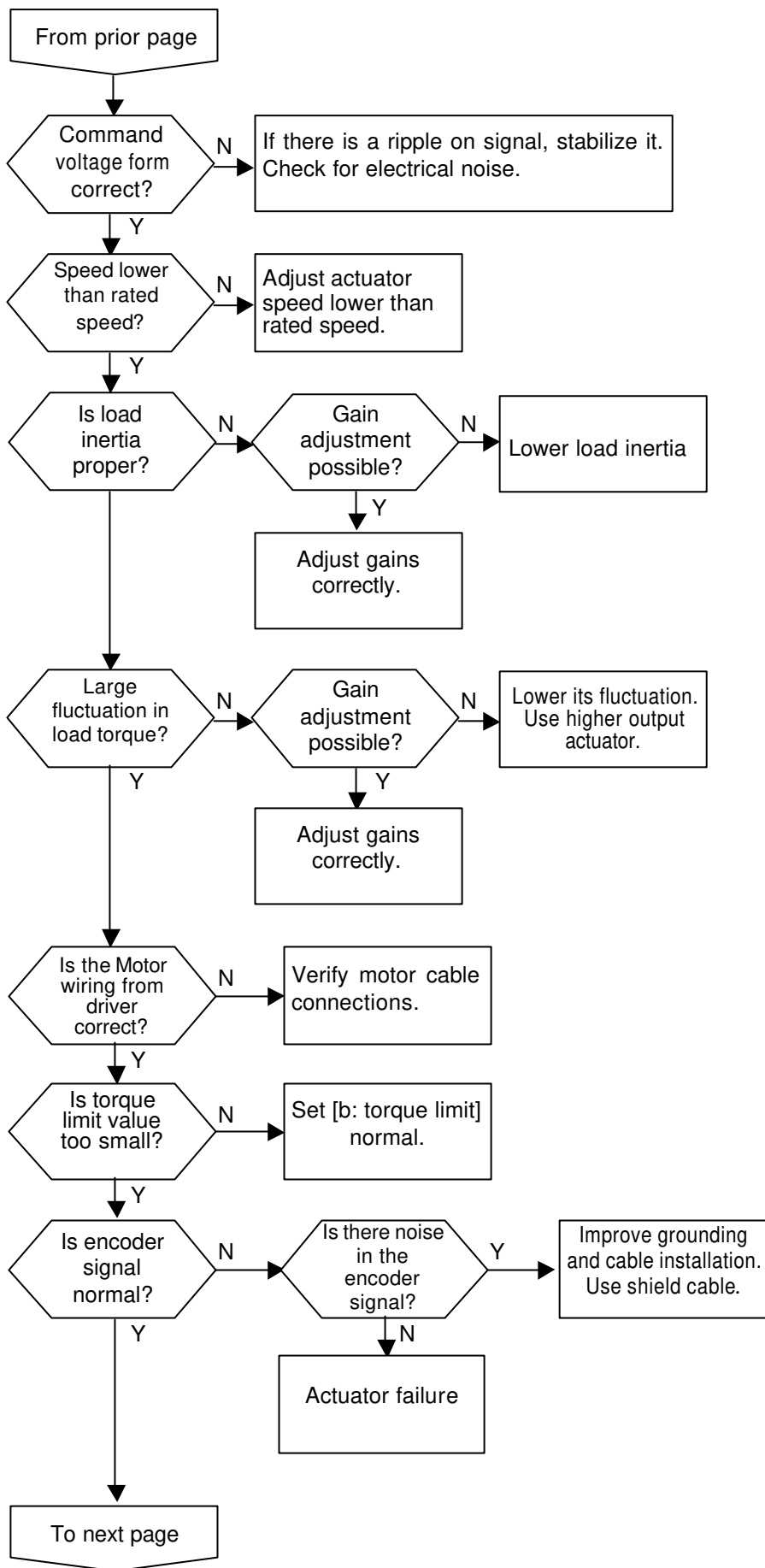

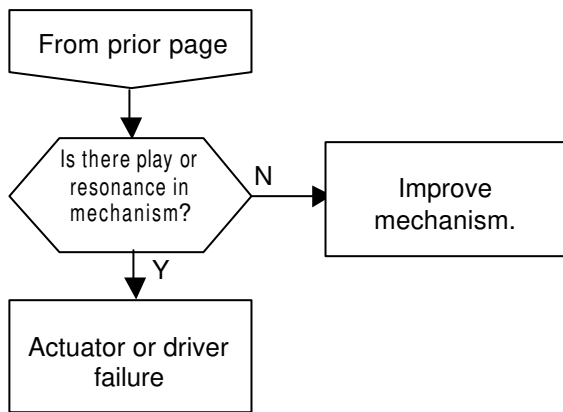

Chapter 8 Options

8-1 Extension cables

Three kinds of optional extension cables of 3m/5m/10m long are available for connecting an FHA-C actuator and an HA-655 driver: for a motor including brake wires, for an incremental encoder system, and for an absolute encoder system.

Ordering model:

for a motor: EWC-MB -M08-TN

for an incremental encoder: EWC-E -B04-3M14

for an absolute encoder: EWC-S -B08-3M14

Cable length

03	3m
05	5m
10	10m



External view of extension cable for motor



External view of extension cable for incremental or absolute encoder

Note: RS-232C communication cable is user's responsibility. Recommended cable is RS-232C cross cable with a DSUB female 9-pin connector for HA-655 driver: KRS-L09-2K or equivalent manufactured by Sanwa Supply.

8-2 Connectors

Connectors for CN1 and CN2 connectors of HA-655, and terminal blocks for motor connection and power supply are optionally available as follows:

Ordering model: CNK-HA65-S1

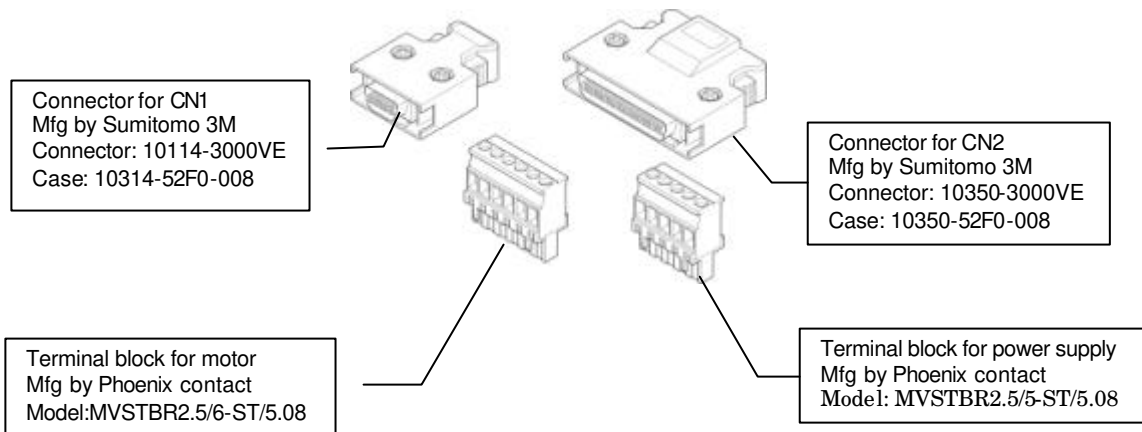

8-3 Software for setting up parameters

The software helps out with setting up parameters of HA-655 driver connecting a personal computer. For the details of the software, please ask us the instructions of PSF-650 software.

Ordering model: PSF-650
Operating system: Windows95/98/Me/NT
Notice: Windows is a registered trademark of Microsoft Corporation.
Link to CN3 port of HA-655 driver: RS-232C cable

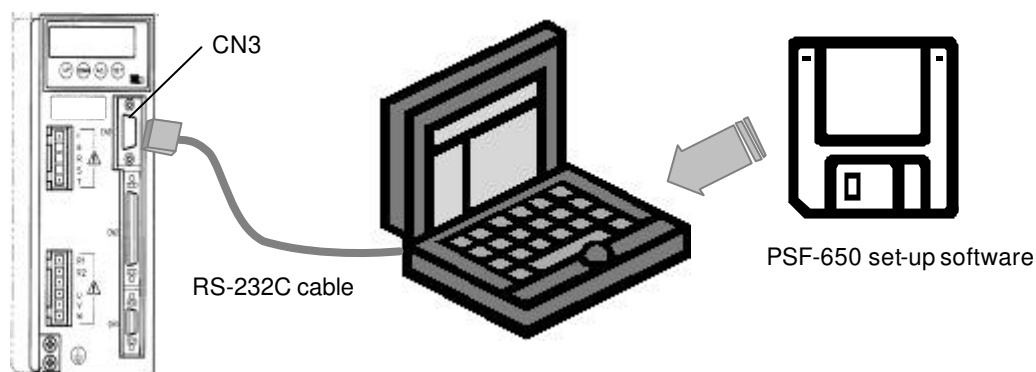

8-4 Backup battery for absolute encoders

For protecting the absolute memory against volatilizing while control power is OFF, the HA-655 driver provides a battery.

Ordering model: HAB-ER17/33
Lifetime: about one year after control power OFF
(conditions: at ambient temperature: 25 degree C, no rotation)
actual lifetime depends on servicing conditions.
Specifications: lithium battery
model: ER17/33 (3.6V 1600mAh) manufactured by Hitachi Maxell co., Ltd.
Harmonic Drive Systems Inc. is possible to supply the batteries on request.



8-5 Isolation transformer

◆ Models

The model of the Isolation transformer is as follows:

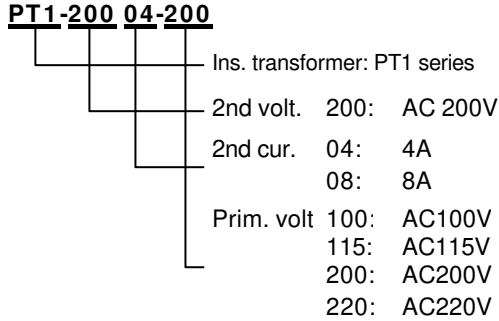

◆ Specifications

The specifications of transformers are as follows:

	PT1-20004-XXX	PT1-20008-XXX
Rated 2nd voltage	200V	200V
Rated 2nd current	4A	8A
Rated prim. Volt.	AC100/115/200/220V, 50/60Hz	
Rated capacity	800VA	1600VA
Isolation class	B-class Isolation	
Ins. resistance	500M ohm or more (DC 1000V)	
Withstand voltage	AC2000V 1minute (50/60Hz)	
Amb. temperature	- 10 to +55°C	
Overheat protection	Built-in thermal protector (cutoff temperature: 130°C)	

◆ External dimensions

The external dimensions of the transformers are as follows:

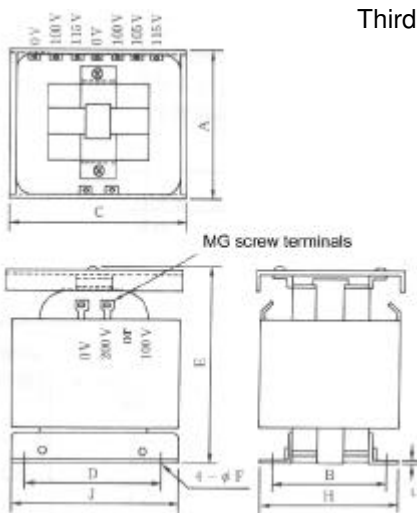

Model	A	B	C	D	E	F
PT1-20004	145	96	150	120	160	6.5
PT1-20008	180	127	165	127	195	6.5

Model	G	H	J	t	Mass
PT1-20004	4	120	140	1.6	7.5kg
PT1-20008	4	150	155	2.3	14.5kg

◆ Connections

The schematic of the transformers are shown below in the figure to the left. When the primary voltage is one of 100/115/200/220V, connect terminals as shown below in the figures to the right.

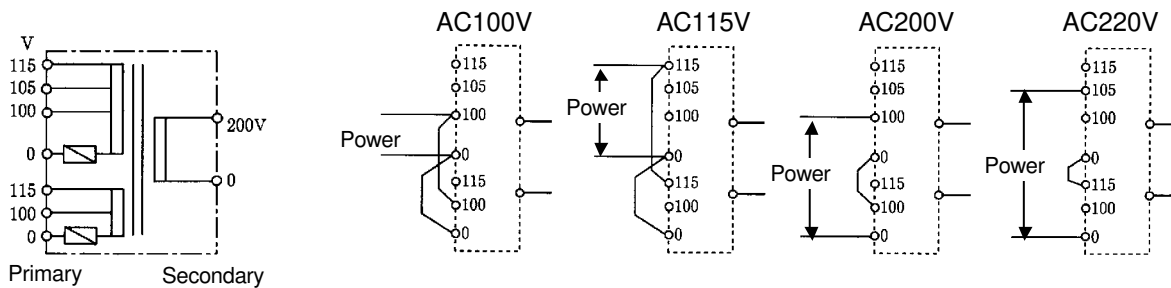

Index

+24V	36	Deceleration time constant	19, 100
1-pulse train	14, 105	Default	121
2-phase-pulse train	15, 105	EIA-422A	16
2-pulse-train	14, 105	Electronic gear	15, 106
A-B phase with 90° difference	15	Encoder cable	66, 141
Abnormal encoder signal	127	Encoder failure	126
Abnormal regeneration	126	Encoder signal	16
ABS-CLEAR	35, 50	Energy saving mode	17
ABS low battery voltage	129	Environmental condition	59
ABSMTD overflow	128	Error counter cleared by S-ON	107
ABS multi-turn data clear	18, 35, 50, 111	Error counter state	82
ABS multi-turn data error	129	Error counter overflow	130
Absolute data request	21, 35, 50	Error counts	24
Absolute encoder	17, 32, 43, 46, 56	Error pulse counts	84
ABS-REQ	35, 50	Exchanging procedure	22
ABS send data rule error	130	Feedback pulse	86
ABS system failure	128	Feed-forward	25
Acceleration time constant	29, 100	Feed-forward gain	97
Actuator code	91	FG	40, 54
ALARM	38, 52	FWD-EN	49
Alarm	39, 53	FWD enable	27, 49
Alarm history	90	FWD inhibit	26, 34
Alarm logic	111	FWD pulse	36
ALM-A, -B, -C, -D	39, 53	FWD/REV pulse train	14
Analog monitor manual output	119	Fuse	65
Acquisition sequence	18	Gain	24
Attained speed	52, 98	Grounding	60
Backup system	22	Grounding cable	63
Battery	22, 142	Ground wire	65
Cable	64, 141	HI-SPD	52
Circuit breaker	65	Humidity	59
CLEAR	34, 48	Hunting	94, 96
Clear	34, 48	I/O monitor	30, 89, 118
CMD-CHG	29, 40	I/O port connection	33, 47
Command change	29, 40, 49	I/O ports	31, 32, 45, 46
Command configuration	14, 105	I/O signal cable	66
Command pulse frequency	88	Impact	59
Command pulse	87	Incremental encoder	16, 31, 41, 45, 55
Command transmitting	16	Index	16
Condenser	22	IN-POS	37
Connector	32, 46, 141	In-position	26, 37
Control mode	104	In-position range	98
Counter	17	Input	33, 47
CPU failure	132	INPUT-COM	34, 35, 48, 49
CUR-MON	35, 50	Input common	34, 35, 48, 49
Current monitor	35, 50, 119	Input port	36
Daily maintenance	78	Input signal common	34, 48
Data request	21	Installing	60

Internal speed command	99	Protocol	20
Isolation transformer	64, 143	Pulse count indication	30
JOG acceleration	116	Quadruple	15, 105
JOG operation	30, 115	Ready	38, 52
JOG speed	116	Regenerative resistor cable	65
Kp	24	Reset	22
Line-driver	16, 36	REV-EN	49
Manual JOG operation	30	REV enable	27, 49
Memory failure (EEROM)	132	REV inhibit	26, 34
Memory failure (RAM)	131	REV pulse	36
Monitor mode	81	Rotary direction	109
Motor speed	27, 51, 83	RS-232C	5, 20, 141
Multiplication	15	Serial port connector	5
Multiplication of 2-phase pulse	105	Service humidity	59
Multi-turn counter	17	Service temperature	59
Multi-turn data clear	21	Servo gain	28
Noise suppression	60	Servo-ON	34, 48
Noise filter	61	SG-GND	51
Open collector	16, 37	Single-turn absolute encoder	17
OUT-COM	39, 53	Single-turn count	19
Output port operation	117	Software	142
Output	33, 47	S-ON	34, 48
Output common	39, 53	SPD-CMD	51
Over current	125	SPD-MON	35, 50
Overheat	125	Speed command common	51
Over speed	123	Speed command	27, 51
Overload	124	Speed command voltage	27, 83
Overload rate	85	Speed command offset	27, 101
Overshoot	94, 96	Speed command auto-offset	120
Parameter mode	102	Speed mode	27, 45
Phase-A output	40, 54	Speed conversion factor	27, 109
Phase-A pulse	16	Speed limit	110
Phase-B output	40, 54	Speed loop	24
Phase-B pulse	16	Speed loop gain	25, 28, 94
Phase-C	16	Speed loop integral compensation	25, 28, 95
Phase-C pulse	16	Speed monitor	27, 50, 119
Phase-Z	16, 39, 53	Temperature	59
Pin-layout	66, 67	Test mode	113
Polarity + pulse train	14	Test run	70
Position error allowance	108	Torque limit	110
Position mode	14	Torque monitor	85
Position loop	24	Tune mode	92
Position loop gain	24, 96	Usual operation	78
Power cable	63	UVW failure	127
Power consumption	59	Vibration	59
Power supply	63	Wire size	63
Power-OFF sequence	68	Z	39, 53
Power-ON sequence	68	Zero clamp	29, 108

Warranty Period and Terms

The HA-655 series drivers are warranted as follows:

- **Warranty period**

Under the condition that the actuator are handled, used and maintained properly followed each item of the documents and the manuals, all the HA-655 series drivers are warranted against defects in workmanship and materials for the shorter period of either one year after delivery or 2,000 hours of operation time.

- **Warranty terms**

All the HA-655 series drivers are warranted against defects in workmanship and materials for the warranted period. This limited warranty does not apply to any product that has been subject to:

- (1) user's misapplication, improper installation, inadequate maintenance, or misuse.
- (2) disassembling, modification or repair by others than Harmonic Drive Systems, Inc.
- (3) imperfection caused by the other than the FHA-C series actuator and the HA-655 servo driver.
- (4) disaster or others that does not belong to the responsibility of Harmonic Drive Systems, Inc.

Our liability shall be limited exclusively to repairing or replacing the product only found by Harmonic Drive Systems, Inc. to be defective. Harmonic Drive Systems, Inc. shall not be liable for consequential damages of other equipment caused by the defective products, and shall not be liable for the incidental and consequential expenses and the labor costs for detaching and installing to the driven equipment



Certified to ISO9001 / ISO14001(TJV PRODUCT SERVICE JAPAN)
All specifications and dimensions in this manual subject to change without notice.

	<p>Head Office / Believe Omori 7F 6-25-3 Minami-Ohi, Shinagawa-ku, Tokyo, Japan 〒140-0013 TEL03(5471)7800 FAX03(5471)7811</p> <p>Overseas Group / 1856-1 Maki Hotaka-cho Minami-Azumigun, Nagano, Japan 〒399-8305 TEL0263(83)7387 FAX0263(83)7384</p> <p>HODAKA Plant / 1856-1 Maki Hotaka-cho Minami-Azumigun, Nagano, Japan 〒399-8305 TEL0263(83)6800 FAX0263(83)6901</p> <p>Harmonic Drive AG / Hoenbergstraße 14, 65555 Limburg, Germany TEL06431-5008-0 FAX06431-5008-18</p> <p>HD Systems, Inc. / 89 Cabot Court, Hauppauge, N.Y. 11788, U.S.A. TEL631-231-6630 FAX631-231-6803</p>
--	---